

Tubular Heater Specifications 10-2
Tubular Heater Terminations..... 10-4
Tubular Heater Mounting 10-5
Tubular Heater Moisture Seals 10-7
Standard Sizes and Ratings 10-8
Typical Bend Formations 10-10
**Tubular Heaters for
 Hot Runner Manifolds 10-14**

10
SECTION

TUBULAR HEATERS



Tubular Heaters

Tubular Heater Applications

- Forced air heating
- Thermal forming machines
- Direct immersion in liquids
- Comfort radiant heaters
- Welded, brazed or clamped to tanks and pipes
- Hot runner molds
- Combination radiant and convection heater for ovens and dryers

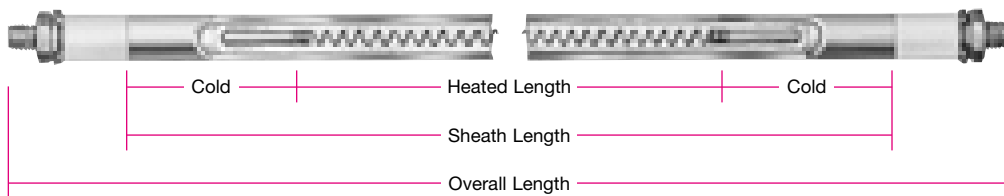

Design Specifications

Resistance Tolerance

Tubular heating elements have an Industry Standard Resistance Tolerance of +10%, -5% which translates to a Wattage Tolerance of +5%, -10%. Consult Tempco if tighter tolerances are required for your application.

Watt Density

Element Watt Density is the wattage dissipated per square inch of the element sheath surface and is critical to the proper heating of the application and to the life expectancy of the heater. The Watt Density is calculated with the following formula:

$$\text{Watt Density (w/in}^2\text{)} = \frac{\text{Element Wattage}}{\pi \times \text{Element Dia.} \times \text{Element Heated Length}}$$

For a particular application element watt density will govern element sheath and internal resistance wire temperature. Factors to consider when choosing a suitable watt density are:

1. Many materials are heat sensitive and can decompose or be damaged if the element is running too hot.
2. Air and other gases that are poor conductors of heat require watt densities matched to the velocity of the gas flow to prevent element overheating.
3. When heating hard water or cleaning solutions mineral deposits can build up on the element sheath, acting as a heat insulator and raising the internal element temperature. If these deposits can not be periodically removed use a lower watt density element to increase heater life expectancy.
4. Page 16-12 in the Engineering Data Section of this catalog lists the maximum recommended heater watt density for many materials. For additional information and help please contact TEMPCO.



Important Note — When heating any substance it is critical to match the heater watt density, operating temperature and sheath material to the specific medium being heated. Failure to do so can result in premature heater failure and/or unsafe conditions.

Construction

TEMPCO Tubular Heaters are the most versatile and widely used source of electric heat for industrial, commercial and scientific applications. They can be designed in a wide range of electrical ratings, diameters, lengths, terminations, and sheath materials. Important and useful characteristics of tubular heaters are that they can be formed into virtually any shape, brazed or welded to any metal surface, and cast into metals. Carefully researched manufacturing methods and quality materials have made Tempco tubular heaters stand apart from other heating elements claiming similar performance.

The cut-away view shows the tubular heater's basic construction. A computer-designed helical coil of 80% Nickel 20% Chromium alloy resistance wire is fusion welded to the nickel-coated steel terminal cold pin. This coil assembly is precisely stretched and centered in the element metal sheath, which is then filled with Grade "A" Magnesium Oxide powder (MgO). The filled tube is then compacted by a roll reduction mill into a solid mass, permanently stabilizing

the coil in the center of the tube while providing excellent heat transfer and dielectric strength between the coil and the sheath.



Tempco Tubular Heating Elements have been certified as Recognized Components by Underwriters Laboratories (File Number E90771) under Classification UBJY2 after testing to meet Standard UL1030. Tempco's equivalent CSA File number is LR430990-5.

These files specify the Watt Density limitation per application type and any other limitations imposed by these agencies in the use of this type of heater. For additional information consult Tempco.

If you require UL and/or CSA approval please specify when ordering.





Element Diameter		Maximum Voltage	Maximum Amperage	Resistance in Ohms per Heated Inch		Sheath Length			
in	mm			min	max	min		max	
.260	6.6	250	15	.100	17	11	279	200	5080
.315	8.0	480	30	.060	21	11	279	200	5080
.375	9.5	480	30	.040	21	11	279	230	5842
.430	10.9	600	40	.040	21	11	279	268	6807
.475	12.0	600	40	.040	21	11	279	275	6985
.625	15.9	600	40	.040	17	11	279	255	6475

Table 1 Electrical Limitations and Minimum/Maximum Sheath Lengths

Length		Sheath Length Tolerance		Heated Length Tolerance		Minimum Unheated Length Each End	
in	mm	in	mm	in	mm	in	mm
11-20	279-508	$\pm\frac{3}{32}$	2	$\pm\frac{1}{4}$	6	1	25
21-50	509-1270	$\pm\frac{1}{8}$	3	$\pm\frac{1}{2}$	13	$1\frac{1}{4}$	32
51-80	1271-2032	$\pm\frac{5}{32}$	4	$\pm\frac{7}{8}$	22	$1\frac{1}{2}$	38
81-110	2033-2794	$\pm\frac{3}{16}$	5	$\pm 1\frac{1}{8}$	29	$1\frac{5}{8}$	42
111-140	2795-3556	$\pm\frac{7}{32}$	6	$\pm 1\frac{3}{8}$	35	$1\frac{3}{4}$	44
141-170	3557-4318	$\pm\frac{1}{4}$	6	$\pm 1\frac{1}{8}$	41	2	51
171-200	4319-5080	$\pm\frac{3}{8}$	10	$\pm 1\frac{7}{8}$	48	$2\frac{1}{4}$	57
201-UP	5081-up	$\pm\frac{1}{2}$	13	$\pm 2\frac{1}{8}$	60	$2\frac{1}{2}$	64

Table 2 Sheath and Heated Length Tolerance (applicable for all diameters)

Standard Sheath Materials

The selection of a sheath material should be made based on the the chemical composition of the solution being heated, character of materials entering the solution, and the processes controls. A material selection guide can be found on page 16-12.

The following are the most common tubular element sheath materials. For other materials consult TEMPCO.

Incoloy® 800 A Nickel (30-35%), Chromium (19-23%), Iron Alloy. The high nickel content of this alloy contributes to its resistance to scaling and corrosion. Used in air heating (also see Incoloy® 840) and immersion heating of potable water and other liquids.

Maximum sheath temperature is 1600°F (872°C).*

Incoloy® 840 A Nickel (18-20%), Chromium (18-22%), Iron Alloy having about 10% less nickel than Incoloy 800. Used in many air heating applications where it has exhibited superior oxidation resistance at less cost.

Maximum sheath temperature is 1600°F (872°C).*

304 Stainless Steel A Chromium (18-20%), Nickel (8-11%), Iron Alloy used in the food industry, sterilizing solutions, and many organic and inorganic chemicals.

Maximum sheath temperature is 1200°F (649°C).*

321 Stainless Steel A Chromium (17-20%), Nickel (9-13%), Iron Alloy modified with the addition of titanium to prevent carbide precipitation and resulting intergranular corrosion that can take place in certain mediums when operating in the 800-1200°F (427-649°C) temperature range.

Maximum sheath temperature is 1200°F (649°C).*

316 Stainless Steel A Chromium (16-18%), Nickel (11-14%), Iron Alloy with Molybdenum (2-3%) added to improve corrosion resistance in certain environments, especially those which would tend to cause pitting due to the presence of chlorides. Applications include deionized water.

Maximum sheath temperature is 1200°F (649°C).*

Copper Mainly used in clean water heating for washrooms, showers, rinse tanks and freeze protection of storage tanks.

Maximum sheath temperature is 350°F (177°C).*

Low Carbon Steel Applications include fluid heat transfer media, tar, high to low viscosity petroleum oils, asphalt, wax, molten salt, and other solutions not corrosive to a steel sheath.

Maximum sheath temperature is 750°F (399°C).*

* Refers to maximum temperature of element material. Consideration must be given to maximum temperature the heated material can safely see. See **Watt Density** on the previous page for more information.

Incoloy® and Stainless Steel Element Sheath Surface Treatments

The surface of the tubular heating elements and other assembly parts in contact with the medium being heated can be passivated or electro-polished to improve their resistance to corrosion.

Passivation removes surface contamination, usually iron, so that the optimum corrosion resistance of the stainless steel is maintained. Surface contamination could come from the small amount of steel that may be worn off a tool during the manufacturing process.

Electro-Polishing is an electrochemical process that removes surface imperfections and contaminants, enhancing the corrosion resisting ability of the sheath. The resulting surface is clean, smooth and has a bright finish; it is highly recommended for medical, food and other harsh applications.



Terminations

Select the termination style that meets your requirements for space, accessibility and reliability.



If the listed terminations do not seem to fit your requirements call us and let us design one that will.

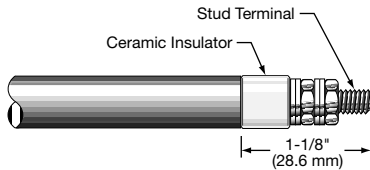

TYPE T—STANDARD

Threaded stud terminal with ceramic insulator. Standard thread size is 6-32 for .260 (6.6 mm), 8-32 for .315 (8 mm) and 10-32 for all other diameters. Other thread sizes and lengths are available to accommodate any electrical requirements and clearance restrictions.

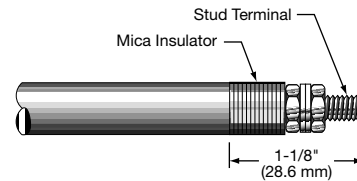

TYPE TM—Stud with Mica Insulator

Stud terminal with mica insulator. Standard thread size is 6-32 for .260 (6.6 mm), 8-32 for .315 (8 mm) and 10-32 for all other diameters. Other thread sizes and lengths are available to accommodate any electrical requirements and clearance restrictions.



TYPE P—Plain Pin

Plain terminal pin. Specify Length "L".
Standard — 1/2" (12.7 mm) pin length.

Element Diameter		Nominal Pin Diameter	
in	mm	in	mm
.260	6.6	.088	2.2
.315	8.0	.100	2.5
.375	9.5	.100	2.5
.430	10.9	.120	3.2
.475	12.0	.120	3.2
.625	15.9	.120	3.2

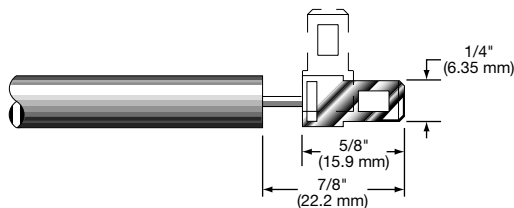

TYPE SF & SF9 (90°)—Quick Connect

Male quick connect (slip-on) terminals are welded to the element terminal pin. They provide quick and easy installation of wires with excellent holding force. Material: Nickel-Plated Steel.

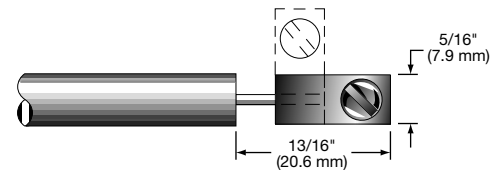

TYPE L & L9 (90°)—Terminal Lug

A nickel-plated steel lug is projection welded to the terminal pin straight (Type "L") or at 90° to the sheath (Type "9L").

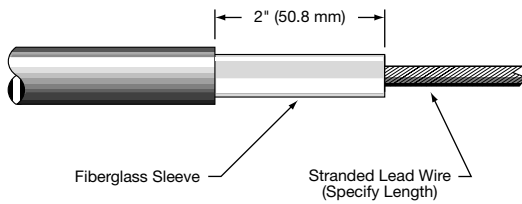

TYPE F1__ –Lead Wire

Type F1A Type TGGT (Teflon® tape, fiberglass, Teflon® treated overbraid) insulation rated to 482°F (250°C).

Type F1B Type MGT (mica tape, Teflon® treated overbraid) insulation rated to 842°F (450°C).

Standard 10" (254 mm) leads. Specify longer leads.

Wire gauge is determined by ampacity of heater and ambient temperature.

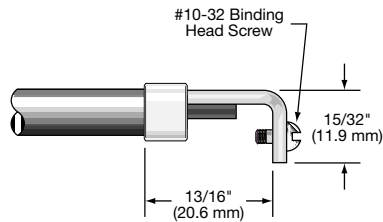

TYPE A—Right-Angle Terminal

Mounting Methods

continued on next page

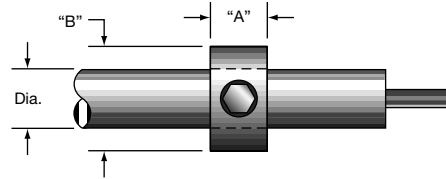

TYPE MC—Mounting Collar

Plated steel mounting collars are locked in place with a set-screw and serve as an adjustable stop for through the wall mounting. Collars are shipped in bulk unless otherwise specified.

Element Diameter		"A"		"B"	
in	mm	in	mm	in	mm
.260	6.6	5/16	7.1	5/8	15.9
.315	8.0	3/8	8.7	3/4	19.0
.375	9.5	7/16	11.1	7/8	22.2
.430	10.9	7/16	11.1	7/8	22.2
.475	12.0	7/16	11.1	1	25.4

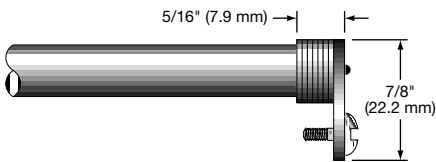

TYPE E—Right-Angle Lug Terminal

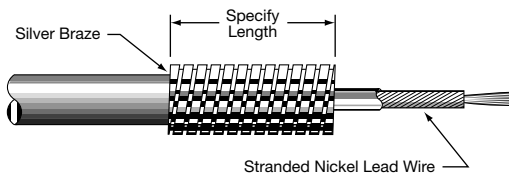

TYPE R1__ –Flexible Armor Cable

Type R1A Galvanized cable

Type R1B Stainless steel cable

Provides excellent protection to lead wires in abrasive environments. Specify cable length and lead wire length.

Standard 10" (254 mm) armor cable over 12" (305 mm) leads. Specify longer leads or cable.

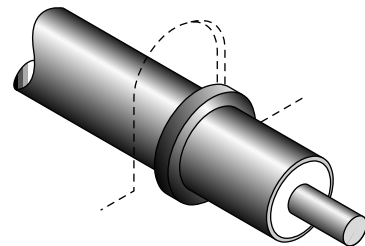

TYPE LR—Locator Ring

Locator rings are permanently attached to the heater sheath and are used to limit the movement of the heater while allowing for expansion and contraction of the heater sheath. When ordering specify location from end of sheath.



Mounting Methods

continued from previous page

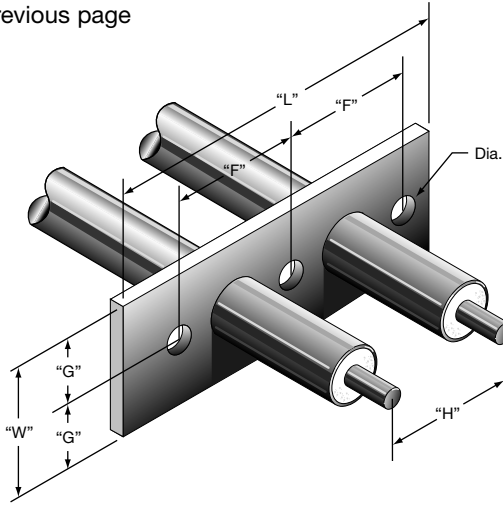

TYPE MF—Mounting Bracket

The 16 gauge Stainless Steel Mounting bracket is an economical way to mount the heater in non-pressurized, non liquid applications. Unless otherwise specified the bracket will be located 1/2" (13 mm) from the edge of the heater sheath.

Custom brackets of any size, thickness and material can also be supplied to meet your requirements.

Heater with multiple elements in a custom mounting bracket.



Custom fittings? No Problem.
We make our own.

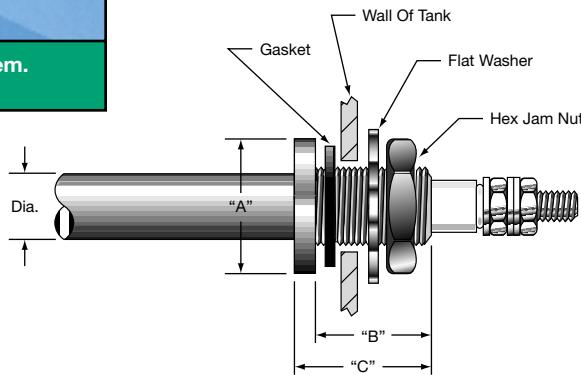

Type "B" Watertight Bulkhead Fittings

Bulkhead fittings provide a leak-proof method for mounting tubular heating elements through tank walls. A gasket, plated steel washer and brass hex jam nuts are included. Specify if a stainless steel washer and jam nut are required when ordering stainless steel fittings.

Standard mounting location is the threaded end of the bulkhead flush with the end of the element sheath. For other mounting locations specify distance from end of sheath to gasket surface on bulkhead.

Fittings are silver brazed or TIG welded to the element, depending on fitting material and customer application.

Fittings in table are the most commonly used. Special fittings can be manufactured to meet your requirements.

Specify: material, flange type, thread type and length.

Tubular Diameter	Fitting Material	Flange Type	"A"		"B"		"C"		Thread Size (UNF)
			in	mm	in	mm	in	mm	
.260	Brass	Round	3/4	19	1/2	12.7	5/8	16	1/2-20
.260	Stn. Stl.	Round	3/4	19	1/2	12.7	5/8	16	1/2-20
.315	Brass	Round	3/4	19	1/2	12.7	5/8	16	1/2-20
.315	Stn. Stl.	Round	3/4	19	1/2	12.7	5/8	16	1/2-20
.375	Brass	Round	3/4	19	1/2	12.7	5/8	16	1/2-20
.375	Stn. Stl.	Round	3/4	19	1/2	12.7	5/8	16	1/2-20
.430	Brass	Round or Hex	7/8	22	3/4	19.0	7/8	22	5/8-18
.430	Stn. Stl.	Round or Hex	7/8	22	3/4	19.0	7/8	22	5/8-18
.430	Steel	Round	7/8	22	3/4	19.0	7/8	22	5/8-18
.475	Brass	Round	7/8	22	3/4	19.0	7/8	22	5/8-18
.475	Stn. Stl.	Round	7/8	22	3/4	19.0	7/8	22	5/8-18
.475	Steel	Round	7/8	22	3/4	19.0	7/8	22	5/8-18
.475	Brass	Round	1	25	3/4	19.0	7/8	22	3/4-16
.475	Stn. Stl.	Round	1	25	3/4	19.0	7/8	22	3/4-16
.625	Stn. Stl.	Round	1 1/8	32	3/4	19.0	1	25	7/8-14



Do not position fittings over heated section of element.



Moisture Seals

Magnesium Oxide (MgO) is used as the insulating material in Tempco tubular heaters because of its excellent thermal conductivity and dielectric strength. However, MgO is hygroscopic and can absorb moisture from the atmosphere. This absorption of moisture may be detected when an Insulation Resistance (IR) test is done with a Meg-ohmmeter prior to energizing the heater circuit. In very humid environments circuits utilizing a GFI (ground fault interrupter) for safety may experience nuisance tripping when energizing the heater.

The Tempco manufacturing process produces a dry element with an IR of several thousand megohms minimum. However, after shipment and depending on humidity levels and storage time, a heater can absorb moisture and show a decrease in IR. In many cases, depending on the supply voltage and the application, the heater can be safely energized and will dry itself out.

If a heater has picked up moisture, a safe and effective method of drying it out is to bake it in an oven at 300°F (149°C) until an acceptable IR reading is obtained. When possible, removing the terminal hardware will expedite this process. If this method is not practical consult factory for other recommendations.

For applications where moisture absorption would be unacceptable Tempco has several optional element end seals to retard absorption of moisture in the MgO. If a true hermetic seal is required ceramic to metal end seals (Type H) are available. With any of these seals, the maximum recommended operating temperature must not be exceeded.

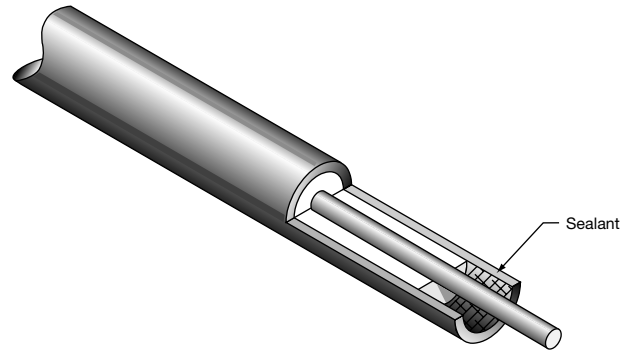

TYPE SS—Silicone Resin Seal

A brushed-on coating that penetrates the MgO, offering economical moisture protection under humid storage conditions. This seal is effective to 390°F (200°C).

TYPE SER—RTV Seal

RTV (room temperature vulcanizing) silicone rubber adhesive sealant provides a good moisture seal. Maximum temperature 450°F (232°C).

TYPE SEH—Epoxy Resin Seal

Epoxy resin provides a moisture barrier primarily for heaters used in water heating applications. Maximum temperature 250°F (121°C).

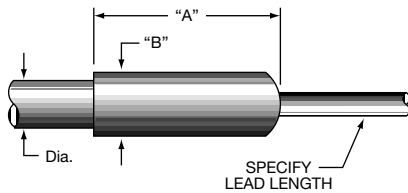

TYPE M—Silicone Rubber Boot

This type seal is used primarily for defrost heaters. Maximum temperature 425°F (218°C).

Heater Diameter		"A"		"B"	
in	mm	in	mm	in	mm
.260	6.6	2 1/8	54	7/16	11
.315	8.0	2 1/8	54	7/16	11
.430	10.9	2 1/8	56	9/16	14

Heater Diameter		"A"		"B"		Thread Size
in	mm	in	mm	in	mm	
.260	6.6	1 11/16	43	13/32	10	8-32
.315	8.0	1 11/16	43	13/32	10	10-32
.430	10.9	2 1/8	54	2 1/32	17	1/4-28
.475	12.1	2 1/8	54	2 1/32	17	1/4-28

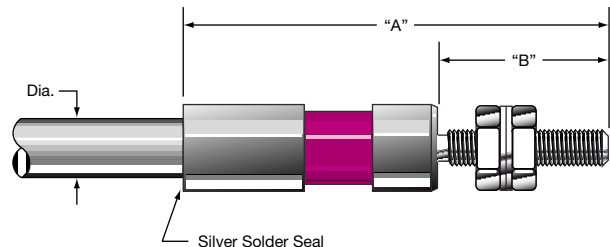

TYPE H—Hermetic Seal

Ceramic to Metal seals provide an airtight seal for temperatures to 500°F (260°C).

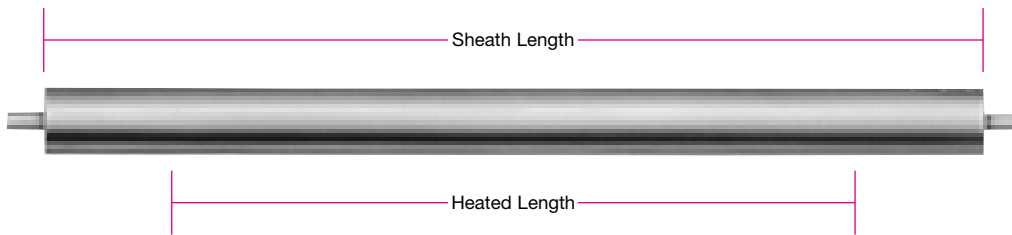

Standard tubular heaters are fully annealed for field or factory bending. They are inventoried with plain pin extensions that allow quick installation of Termination Types T, TM, F1, A, E, SF, SF9, L and L9.

Part Numbers listed are for heaters with Type "T" termination. For other terminations a Part Number will be issued at time of order.

Standard Sizes and Ratings with Type T Termination

Element Description	Sheath Length		Heated Length		Watts	Part Number 240V	Approximate Net Weight		
	in	mm	in	mm			lbs	kgs	
23 W/in² .475 Incoloy	39	991	27	686	1000	*THE04000	1.0	.5	
	54	1372	42	1067	1500	*THE04001	1.1	.5	
	69	1753	57	1448	2000	*THE04002	1.3	.6	
	84	2134	72	1829	2500	*THE04003	1.4	.6	
	12 mm (3.6 W/cm ²)	99	2515	87	2210	3000	*THE04004	1.6	.7
	132	3353	120	3048	4175	THE04005	1.7	.8	
	157	3988	145	3683	5000	THE04006	1.8	.8	
30 W/in² .260 Incoloy	20	508	15	381	400	THE04007	.2	.1	
	25	635	20	508	500	THE04008	.2	.1	
	30	762	25	635	600	*THE04009	.2	.1	
	35	889	30	762	800	*THE03384	.3	.1	
	6.6 mm (4.65 W/cm ²)	40	1016	35	889	900	*THE04010	.3	.1
		45	1143	40	1016	1000	*THE04011	.4	.2
		50	1270	45	1143	1200	*THE04012	.4	.2
		55	1397	50	1270	1200	*THE03383	.4	.2
		60	1524	55	1397	1400	*THE03373	.5	.2
		65	1651	60	1524	1600	*THE02648	.5	.2
	70	1778	65	1651	1800	THE04013	.6	.3	
	75	1905	70	1778	1800	THE04014	.6	.3	
	80	2032	75	1905	2000	THE04015	.6	.3	
30 W/in² .315 Incoloy	15	381	10	254	300	THE04016	.2	.1	
	20	508	15	381	400	THE04017	.3	.1	
	25	635	20	508	600	THE04018	.3	.1	
	30	762	25	635	800	*THE04019	.4	.2	
	35	889	30	762	900	*THE03328	.5	.2	
	40	1016	35	889	1000	*THE04020	.5	.2	
	45	1143	40	1016	1200	*THE04021	.6	.3	
	50	1270	45	1143	1400	*THE04022	.7	.3	
	8.0 mm (4.65 W/cm ²)	55	1397	50	1270	1600	*THE04023	.7	.3
		60	1524	55	1397	1800	*THE03134	.8	.4
		65	1651	60	1524	1800	*THE04024	.9	.4
		70	1778	65	1651	2000	*THE03380	1.0	.5
		75	1905	70	1778	2200	THE04025	1.0	.5
		80	2032	75	1905	2400	THE04026	1.1	.5
		90	2286	85	2159	2600	THE04027	1.2	.5
	100	2504	95	2413	3000	THE04028	1.3	.6	



an asterisk next to the Part Number guarantees in-stock availability for same day shipping when

ORDERED BY 2^{PM} CST



Standard Sizes and Ratings with Type T Termination

Element Description	Sheath Length		Heated Length		Watts	Part Number 240V	Approximate Net Weight	
	in	mm	in	mm			lbs	kgs
30 W/in² .430 Incoloy 10.9 mm (4.7 W/cm ²)	15	381	10	254	400	THE04029	.3	.1
	20	508	15	381	600	THE04030	.5	.2
	25	635	20	508	800	THE04031	.6	.3
	30	762	25	635	1000	THE04032	.7	.3
	35	889	30	762	1200	THE04033	.8	.4
	40	1016	35	889	1400	THE04034	.9	.4
	45	1143	40	1016	1600	THE04035	1.0	.5
	50	1270	45	1143	1800	THE04036	1.1	.5
	55	1397	50	1270	2000	*THE03415	1.3	.6
	60	1524	55	1397	2200	*THE03376	1.4	.6
	65	1651	60	1524	2400	*THE04037	1.5	.7
	70	1778	65	1651	2600	*THE04038	1.6	.7
	75	1905	70	1778	2800	*THE04039	1.7	.8
	80	2032	75	1905	3000	*THE04040	1.8	.8
	90	2286	85	2179	3500	*THE04041	2.0	.9
100	2540	95	2413	4000	*THE03593	2.3	1.0	
110	2794	105	2667	4500	*THE03067	2.5	1.1	
120	3048	115	2921	5000	THE04042	2.7	1.2	
40 W/in² .375 Incoloy 9.5 mm (6.2 W/cm ²)	21 ¹ / ₁₆	535	16 ³ / ₁₆	427	800	THE04043	.4	.2
	27 ¹ / ₈	689	22 ⁷ / ₈	581	1100	*THE04044	.5	.2
	32 ¹ / ₈	816	27 ¹ / ₈	708	1300	*THE04045	.6	.3
	42 ¹ / ₈	1089	38 ⁵ / ₈	981	1800	*THE04046	.8	.4
	57 ¹ / ₂	1461	53 ¹ / ₄	1353	2500	*THE04047	1.1	.5
	69 ¹ / ₄	1759	65	1651	3000	*THE04048	1.3	.6
	81 ¹ / ₄	2064	77	1956	3600	THE04049	1.5	.7
	109 ¹ / ₄	2775	105	2667	4000	THE04050	2.1	1.0
	134 ¹ / ₂	3416	127 ³ / ₄	3245	5000	THE04051	2.5	1.1
153 ³ / ₈	3896	145 ⁷ / ₈	3705	5500	THE04052	2.9	1.3	
179 ¹ / ₄	4553	171 ¹ / ₄	4350	6500	THE04053	3.4	1.5	
48 W/in² .475 Incoloy 12 mm (7.4 W/cm ²)	23	584	14	356	1000	THE04054	.6	.3
	30	762	21	533	1500	THE04055	.9	.4
	39	991	27	686	2000	THE04056	1.1	.5
	44	1118	35	889	2500	THE04057	1.3	.6
	54	1372	42	1067	3000	THE04058	1.6	.7
	69	1753	57	1448	4000	THE04059	2.0	.9
	84	2134	72	1829	5000	THE04060	2.2	1.0
	99	2515	87	2210	6000	THE04061	2.8	1.3
	149	3785	133	3378	9720	THE04062	4.0	1.8

How to Order

Catalog Heaters

Part Numbers preceded by an asterisk (*) are in stock for immediate delivery with Type "T" termination.

Termination Types TM, F1, A, E, SF, SF9, L, and L9 can be applied to stock heaters. For these terminations the Heater Part Number will be issued at time of order.

Part Numbers with no asterisk are standard designs that are available straight in 2 weeks and formed in 4 weeks.

Custom Engineered/Manufactured Heaters

Understanding that an electric heater can be very application specific for sizes and ratings not listed, TEMPCO will design and manufacture a Tubular Heater to meet your requirements. **Standard lead time is 4 weeks.**

Please Specify the following:

- | | |
|--|---|
| <input type="checkbox"/> Type of Application | <input type="checkbox"/> Sheath Material |
| <input type="checkbox"/> Wattage and Voltage | <input type="checkbox"/> Termination Type |
| <input type="checkbox"/> Diameter | <input type="checkbox"/> Type of Mounting, if required |
| <input type="checkbox"/> Heated Length | <input type="checkbox"/> Type of Moisture Seal, if required |
| <input type="checkbox"/> Unheated Length at each end | <input type="checkbox"/> Bending Configuration (Supply drawing and/or sample) |



Forming Tubular Elements

The MgO insulation used in tubular heating elements is compacted by reducing the element diameter. The elements are then annealed in a controlled atmosphere furnace to relieve the metal stressing (work hardening) that takes place during the rolling to size reduction of the sheath. Annealing brings the metal back to a soft state, allowing the element to be bent virtually into any configuration. However, since forming also work hardens the metal, some precautions must be observed in order to prevent the sheath from breaking during bending or developing stress cracking marks.



Note: Elements with tight bends and some applications require the bends to be recompact in special dies to restore the insulation density and maintain dielectric strength.

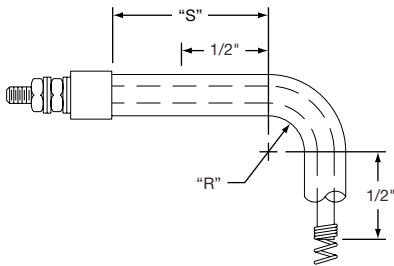

.....
Avoid bends within a minimum of $\frac{1}{2}$ " of the terminal pin and resistance wire junctions unless the bending radius is a minimum 3" (75 mm).

Tubular Element Minimum Bending Radius

Element Diameter		Factory Bend Minimum R		Field Bend Minimum R		Minimum S	
in	mm	in	mm	in	mm	in	mm
.260	6.6	$\frac{3}{8}$	9.5	$\frac{3}{4}$	19.1	$\frac{1}{2}$	12.7
.315	8.0	$\frac{1}{2}$	12.7	1	25.4	$\frac{1}{2}$	12.7
.375	9.5	$\frac{9}{16}$	14.3	2	50.8	$\frac{5}{8}$	15.9
.430	10.9	$\frac{3}{4}$	19.1	$2\frac{1}{2}$	63.5	$\frac{3}{4}$	19.1
.475	12.0	$\frac{7}{8}$	22.2	$2\frac{1}{2}$	63.5	1	25.4



Note: Smaller inside bending radius than listed in the table can be factory accomplished. It requires special forming techniques to prevent damage to the tubular heater. Consult Tempco with your requirements.

Elements are being fed into a Roll Reducing Mill to compact the MgO insulating powder. After rolling, the elements are annealed in the conveyor belt furnace seen in the background.



TYPICAL Bend Formations

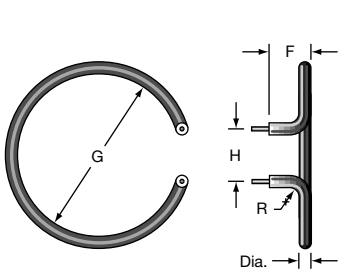

FT1

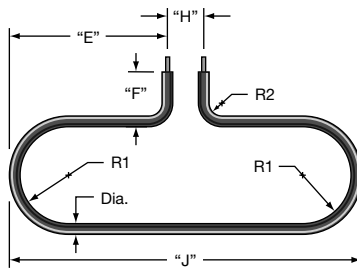

FT2

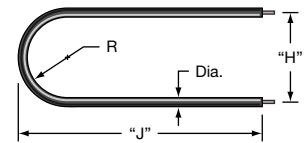

FT3

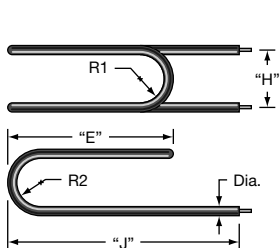

FT4

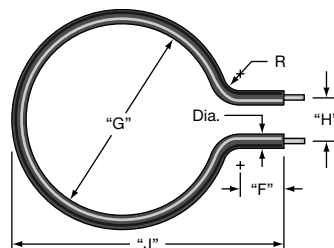

FT5

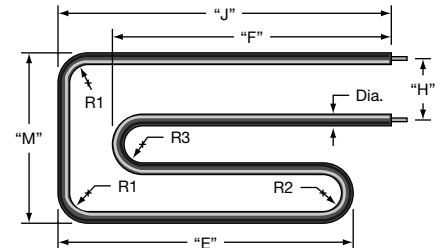

FT6



Bend Formations

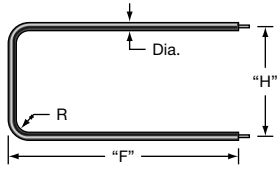

FT7

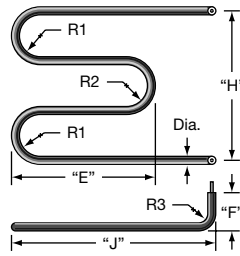

FT8

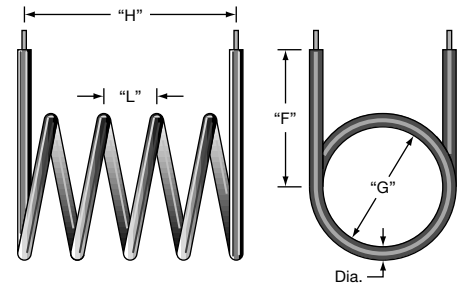

FT9

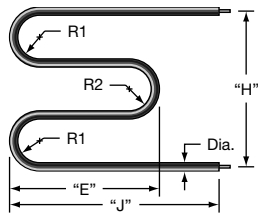

FT10

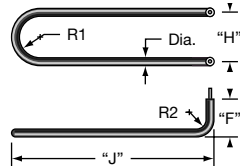

FT11

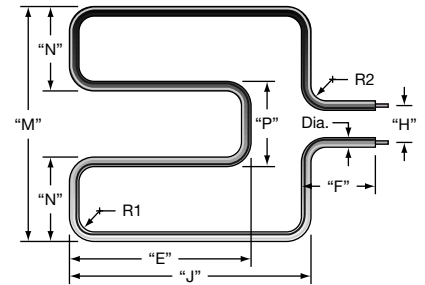

FT12

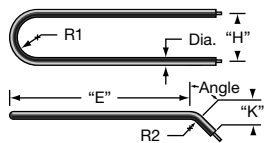

FT13

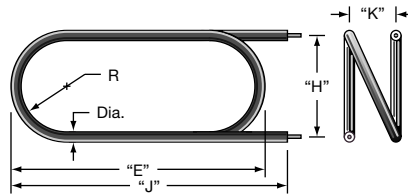

FT14

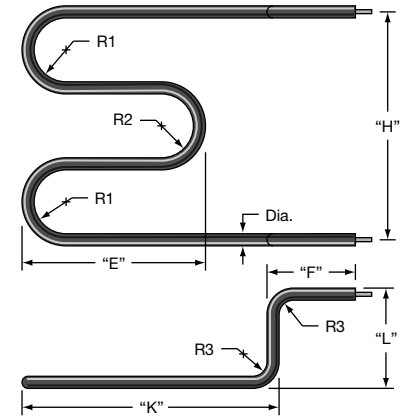

FT15

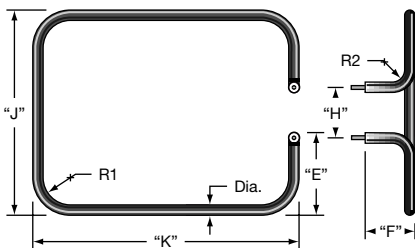

FT16

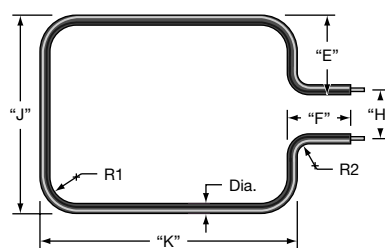

FT17

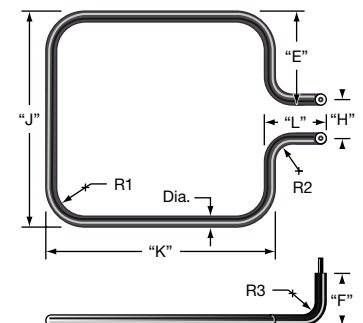

FT18

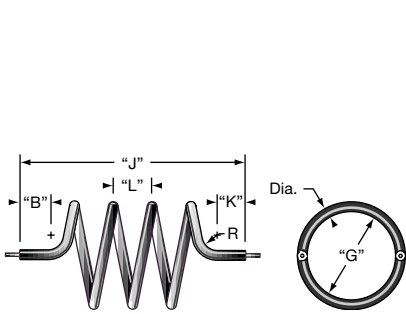

FT19

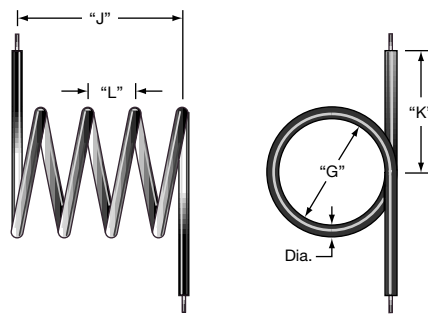

FT20

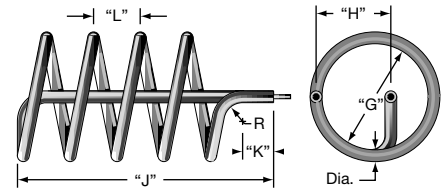

FT21

TYPICAL Bend Formations

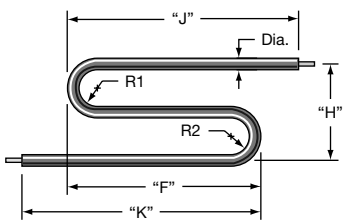

FT22

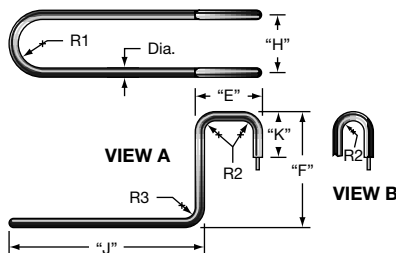

FT23

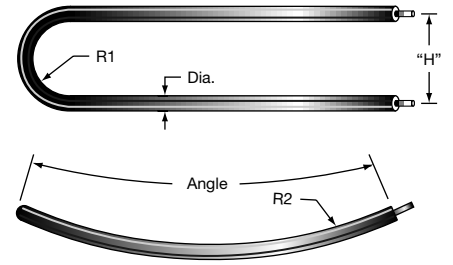

FT24

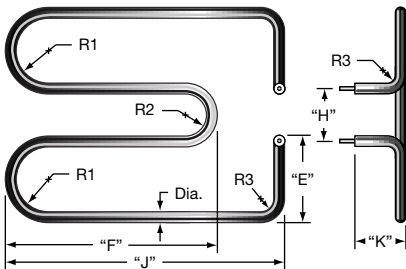

FT25

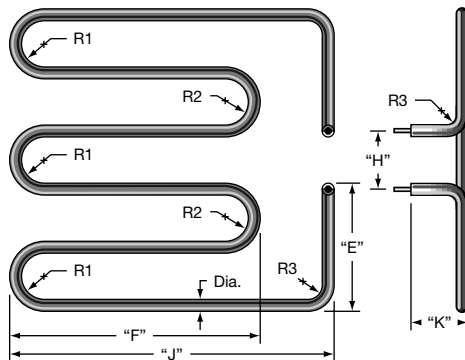

FT26

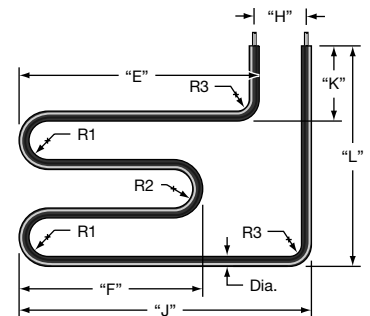

FT27



Bend Formations

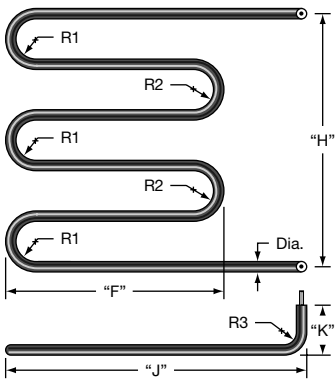

FT28

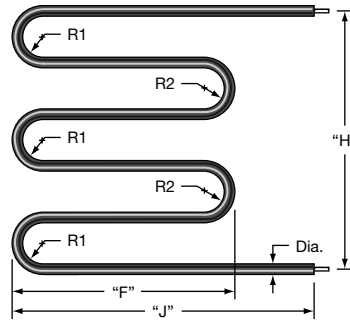

FT29

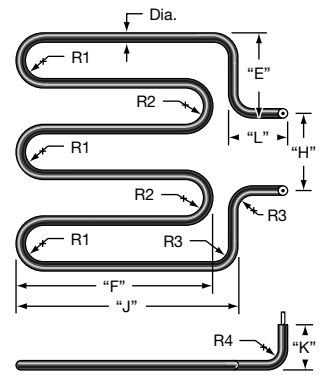

FT30

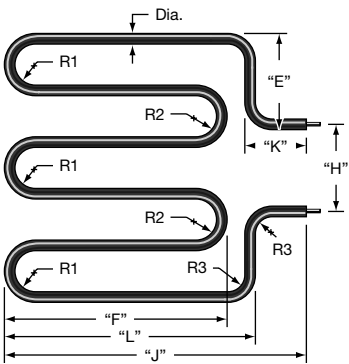

FT31

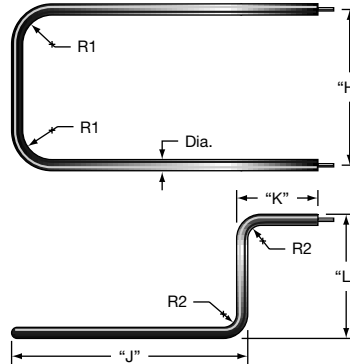

FT32

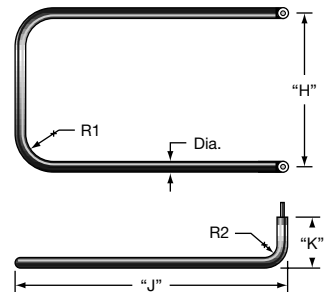

FT33

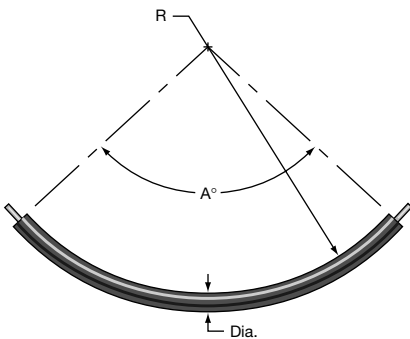

FT34

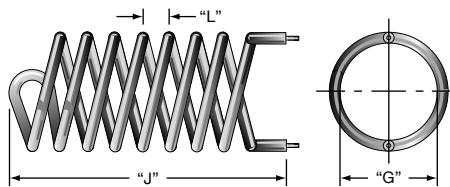

FT35

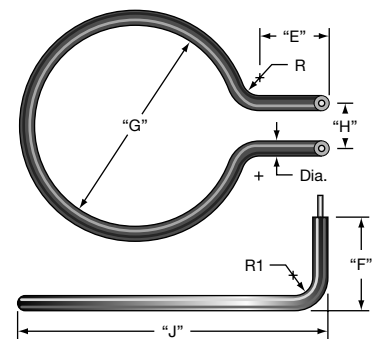

FT36



Tubular Heaters for Hot Runner Manifolds

Construction

Mold Heaters are custom made using .260", .315" or .375" diameter Incoloy® heating elements with threaded stud or lead wire termination.

Important Information on Forming

Precise forming of the heater is required for it to seat properly into the milled slot in the mold. To insure this fit we normally use a template as an inspection tool in the forming process. This template is a reproduction of the milled slot in a plastic or aluminum plate, and can be customer supplied or manufactured by Tempco.

When ordering for new applications:

Supply a drawing or forming template if available.

When ordering for replacement:

Supply a sample heater and/or the dimensions of the groove.



Note: For heaters originally manufactured by Tempco only the Tempco Part Number is required.

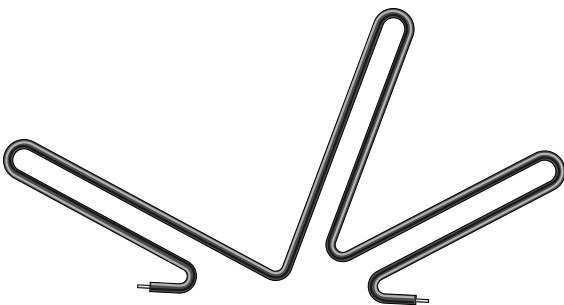
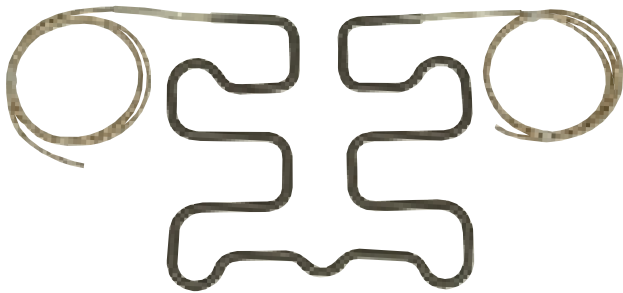

Examples of Mold Heater Formations

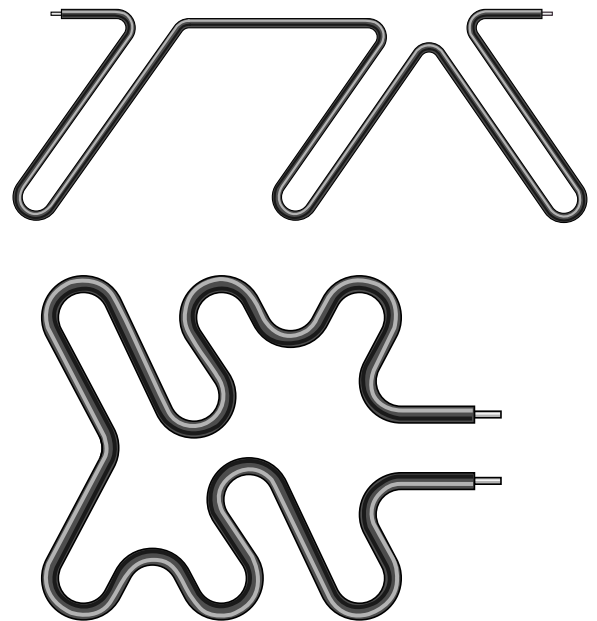
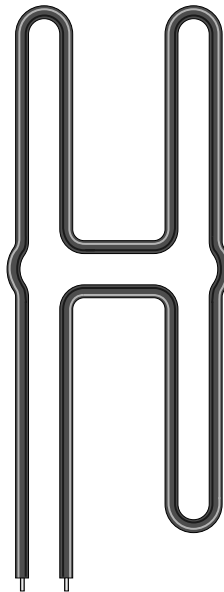
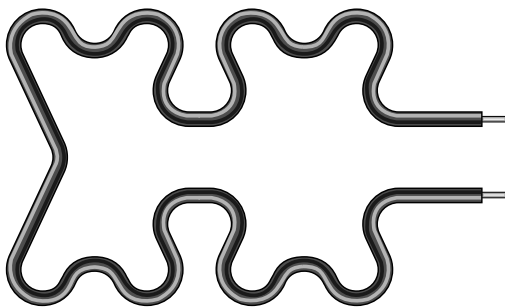

SEA-108-101 is stocked in 1 gallon containers.

Heat Transfer Cement

When tubular heating elements are used in a milled slot any air gaps between the element and the plate can cause hot spots on the element. Heat transfer cement is used to fill these air gaps, permitting the heater to run cooler thus maximizing its life expectancy. Cement is water soluble and can be applied with a putty knife or trowel and can be used in temperatures up to 1250°F (675°C).

Part Number SEA-108-101 (1 Gallon)
SEA-108-102 (1 Quart)

How to Order

TEMPCO will design and manufacture a Tubular Hot Runner Manifold Heater to meet your requirements.

Please Specify the following:

- Wattage and Voltage
- Diameter
- Heated Length
- Unheated Length at each end
- Termination Type (see pages 10-4 and 10-5)
- Supply a Drawing or Template