

APRIL 1991

**Instructions For The 300
Series SELF TUNE[®] plus
Universal Microprocessor
Single Output
Temperature/Process
Control**

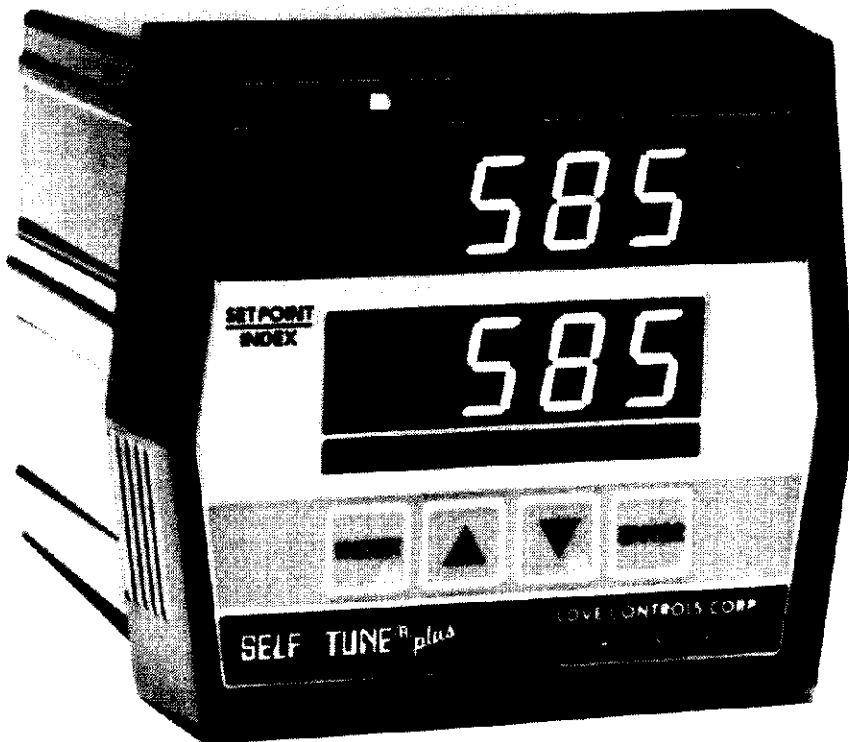

**if all else fails,
please read these
instructions**

PROHEAT

Excellence in distribution

<http://www.proheatinc.com>

117 East Adams Street

P.O. Box 48

LaGrange, KY 40031

Phone (502) 222-1402 Fax (502) 222-0714

Table of Contents

General	
Model Identification	1
Front Panel Presentation	2
Temperature Ranges	2
Description	3
Installation	
Voltage Selection	3
Removal From the Housing	3
Mounting	3-4
Power Wiring	4
Input Wiring	4
Input Selection	
Temperature	4
Voltage and Current	5
External Wiring	
Relay Output Module	6
Triac Driver Module (0.1A)	6
24 V.D.C. Voltage Switch Module	7
Proportional Current Output Module	7
Proportional Voltage Output Module	8
Triac Module (1.0A)	8
Control Operation	
The Security Switch	9
Operation Common to All Models	9-10
Electrical Noise and Using Self Tune	10-11
PID Tuning Procedure (Quick Method)	11
PID Tuning Procedure (Exact Method)	12
Programmable Functions	13
Operational Suggestions and Hints	14
Operation	
With Relay or 24 V.D.C. Voltage Switch Modules	14-15
With Triac Driver Module or Triac Module	15-16
With Proportional Current Output Module	16-17
With Proportional Voltage Output Module	17-18
Alarm Operation	
Operation	18-19
Programmable Functions	18-19
Options	
Factory Programming, Option 520	19
Isolated Power Supply, Option 550	20
Rear Terminal Enclosure, Option 617	20
Splash and Dust Resistant Construction, Option 6156	20
Tamper Resistant Cover, Option 6162	20
Blind Holes for Option 6162, Option 6166	20
Other Options	20
Specifications	20-21
Programming	
Diagnostic Error Messages	22-25
Programming in the Set-up Mode	26-40
Set-up for T/C Short Protection	41
Set-up for Input Correction	41
Low and/or High Output Selection	42
Input or Output Changes	
Changing Sensors	43
Changing Output Modules	43
Dimension Drawing	44
Warranty	44
Factory Default Feature	45-47
Blank Program Selection Table	48-54

Model Identification

The model number appears on the label affixed to the top of the controller. The output module present in your control is as shown by the marked square on the label affixed to the side of the control.

The model number is made up as follows:

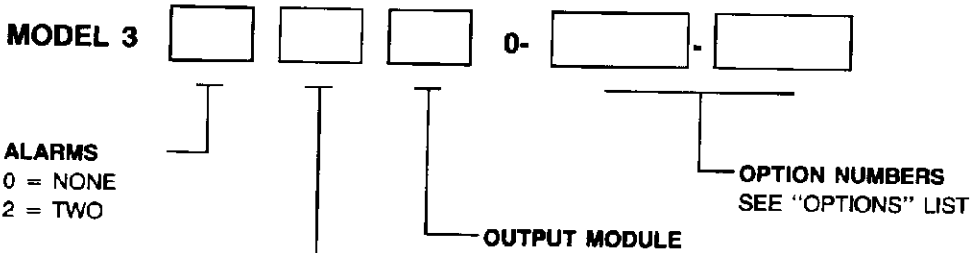

INPUT

- 1 = THERMOCOUPLE J, K AND E
- 2 = THERMOCOUPLE T, R, AND S
- 3 = THERMOCOUPLE B, C AND N
- 4 = 1.0° RTD (CAL. 104, 105 AND 106)
- 5 = 0.1° RTD (CAL. 104, 105 AND 106)
- 6 = D.C. VOLTAGE
- 7 = D.C. CURRENT

- 1 = 9.5A RELAY
- 2 = TRIAC DRIVER, 0.1A SOLID STATE SWITCH
- 3 = 24 V.D.C. VOLTAGE SWITCH (NON-ISOLATED).
- 4 = 0 TO 20 mA D.C. PROPORTIONAL CURRENT (NON-ISOLATED). INTO 0 TO 1000 OHMS MAX.
- 5 = 0 TO 10 V.D.C. PROPORTIONAL VOLTAGE (NON-ISOLATED). INTO 500 OHMS MIN. (20 mA MAX).
- *6 = 0 TO 20 mA D.C. PROPORTIONAL CURRENT (ISOLATED). INTO 0 TO 1000 OHMS MAX.
- *7 = 0 TO 5 V.D.C. PROPORTIONAL VOLTAGE (ISOLATED). INTO 250 OHMS MIN. (20 mA MAX.).
- 8 = 1.0A TRIAC SOLID STATE SWITCH. NOT FOR DRIVING SSR's.

*NOTE: Option 550, isolated power supply **must** be ordered if these output modules are selected.

The following labels are affixed to the control:

The top

PROCESS CONTROL EQUIPMENT

LOVE
CONTROLS CORP., WHEELING, ILL., U.S.A.

MODEL 3 SP1 SP2 -

SEE SIDE LABEL FOR OUTPUT MODULE CODE

LINE INPUT RATING: 120/208/240 VAC, 50/60Hz
SINGLE PHASE, 10 VA. LINE VOLTAGE SELECTION -
INTERNAL JUMPER FACTORY SET AT **240V.**

AMBIENT TEMP. RATING: 131°F (55°C) MAX.
THIS CONTROLLER IS INTENDED FOR PANEL MOUNTING.
TERMINALS MUST BE ENCLOSED WITHIN THE PANEL.
USE NEC CLASS 1 WIRING RATED 75°C MIN.
(USE NO. 14 AWG COPPER CONDUCTORS ONLY)
FOR ALL TERMINALS EXCEPT SENSOR INPUTS (14, 15, 16).
MAINTAIN SEPARATION BETWEEN WIRING OF SENSOR,
DATA CONNECTOR AND OTHER WIRING.

**CAUTION: RISK OF ELECTRIC SHOCK -
MORE THAN ONE DISCONNECT SWITCH
MAY BE REQUIRED TO DE-ENERGIZE
THE EQUIPMENT BEFORE SERVICING.**

280 2318

The side

INTERCHANGEABLE PLUG-IN OUTPUT MODULES MAY
BE USED WITH THIS INSTRUMENT AS FOLLOWS:

CODE	SET	PIN	LOAD	SP1	SP2	PIN	
1	<input type="checkbox"/>	1541-10	10A RELAY	5	<input type="checkbox"/>	3308-150	NON-ISO. VOLTAGE
2	<input type="checkbox"/>	3308-120	SOLID STATE SW.	6	<input type="checkbox"/>	3308-145	ISOLATED CURRENT
3	<input type="checkbox"/>	3308-120	NON-ISO. V. SW.	7	<input type="checkbox"/>	3308-155	VOLTAGE
4	<input type="checkbox"/>	3308-140	CURRENT	8	<input type="checkbox"/>	3308-147	1.0A S.S.S.W.

The Model number is filled in on the above labels at the factory.

The bottom

WIRING TERMINALS:

1	SP1	COM	
2	RELAY	N.O.	9.5A RES. AT 120 VAC *Δ□
3	RELAY	N.C.	5A RES. AT 240 VAC
4	SP2	COM	240 VA P.D. AT 120 OR 240 VAC
5	RELAY	N.O.	
6	RELAY	N.C.	
7	- L1	LINE VOLTAGE - COMMON	
8	- L2	LINE VOLTAGE - REFER TO LINE INPUT RATING	
9	ALARM	(ALL) - N.O. OR N.C.	1A RES. AT 120 VAC
10	RELAYS	(ALL) - COM. FOR ALL 1 & ALL 2	
11	POWER	(ALL) - N.O. OR N.C.	1A RES. AT 120 VAC
12	THRU 15	TERMINALS (WHEN PRESENT) ARE CLASS 2	

REFER TO INSTRUCTION BOOK FOR WIRING & DATA CONN. DIAGRAM AND CONNECTION DESCRIPTION.

WHEN PRESENT:

- * RELAYS DERATED ABOVE 30°C AMBIENT.
- Δ SOLID STATE SWITCH MODULE, RATED 0.1A RES. OR 1A RES. AT 240 VAC, PER OUTPUT MODULE CODE.
- OUTPUT CURRENT OR VOLTAGE MODULES, CLASS 2.

SEE INSTRUCTION BOOK FOR THE ABOVE WIRING AND RATINGS.

280 2318-2

Front Panel Presentation

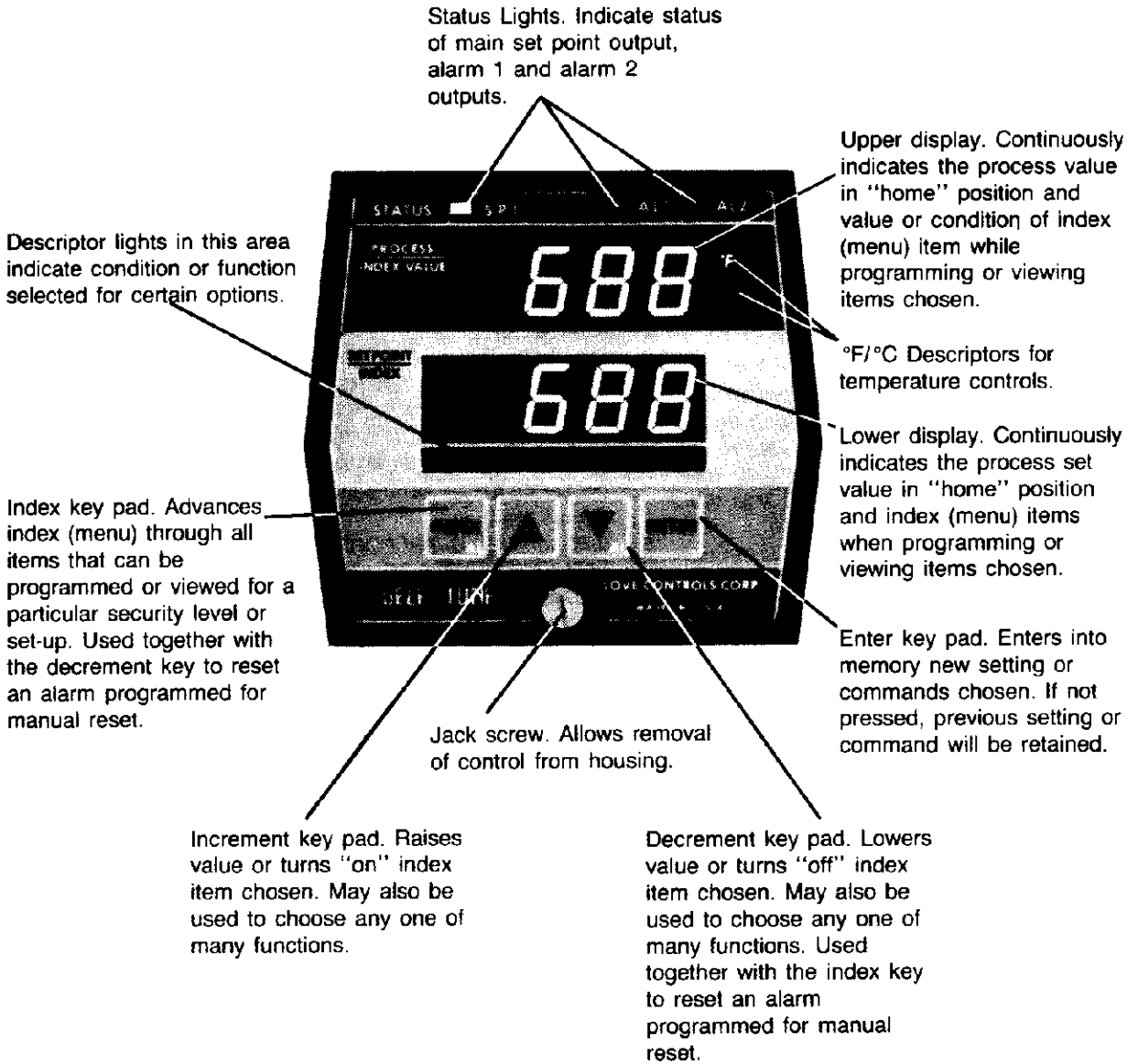

Temperature Ranges

Thermocouple		
Ordering Code	Sensor Type	Range
1	J	-100 to +1600°F/-73 to +871°C
	K	-200 to +2500°F/-129 to +1371°C
	E	-100 to +1800°F/-73 to +982°C
2	T	-350 to +750°F/-212 to +398°C
	R	0 to 3200°F/-17 to +1760°C
	S	0 to 3200°F/-17 to +1760°C
3	B	+32 to +3308°F/0 to 1820°C
	C	+32 to +4172°F/0 to 2300°C
	N	+32 to +2372°F/0 to 1300°C

NOTE: type B will not be within specifications below 400°F/204°C.

RTD		
Ordering Code	Sensor Type	Range
4	100 ohm Plat.	-328 to +1607°F/ 200 to +875°C
	.00385, Cal. 106	
	1.0" Resolution	100 ohm Plat.
5	.00392, Cal. 104	
	120 ohm Nickel, Cal. 105	
	0.1" Resolution	100 ohm Plat.
5	.00385, Cal. 106	
	100 ohm Plat.	
	.00392, Cal. 104	
5	120 ohm Nickel, Cal. 105	

Description

The Love Model 300 Series controls are microprocessor based and include selectable Self-Tune or manual tune P.I.D. functions: gain (band width), reset (integral) and rate (derivative).

Two large LED displays indicate all controller parameters as well as process temperature (or other input variable) and set point value.

A wide selection of inputs are offered with multiple choice thermocouple or RTD selection in the same control. Input scaling may be field programmed for voltage or current inputs.

Output plug-in modules, that can be changed in the field, provide complete output versatility.

Status lights indicate output conditions at all times.

Every parameter of the control may be field adjusted, if desired. Two levels of security are also provided. Four front panel membrane key pads are used to view or change all selected index (menu) items.

Complete non-volatile memory eliminates the need for battery back-up and attendant battery problems.

Many options are available, including two alarm outputs.

Voltage Selection. FAILURE TO SELECT PROPER VOLTAGE CAN RESULT IN TRANSFORMER BURN-OUT.

Check the label affixed to the top of the controller housing to determine the line voltage for which the unit will operate as shipped. This is usually 240 V.A.C. 50/60 HZ.

To change this input voltage, remove the controller from its housing as described under "Removal from the Housing". There is a black jumper located along the right edge of the circuit board as you are facing the rear of the control. This jumper is soldered to one terminal and plugged on to one of the voltage select terminals. These terminals are marked 120V, 208V, or 240V. If you wish to change the voltage input, unplug the jumper from the terminal that it is on, using a long-nosed plier and pulling straight up. Plug it on to the desired voltage terminal. Replace controller into its housing.

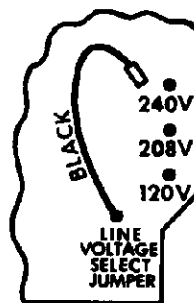

Removal from the Housing

The controller does not have to be removed from its housing for mounting. However, if security switch or alarm jumper changes are required, it will have to be removed.

To remove the controller from its housing, turn the jack screw, located in the center of the bottom edge of the controller face, in a counter-clockwise direction until loose. Push the control forward to slide out of the housing.

To replace, slide the control chassis into the housing in its proper slots until the jack screw is engaged. Turn the jack screw clockwise, while at the same time pushing gently on the top edge of the controller, until tight. **Do not** over tighten.

Mounting

Select a location for mounting where the control will not be subject to excessive temperature, shock, vibration, dust, moisture, oil or other liquids.

All models are designed for mounting in an enclosed panel through a 3½ in. x 3½ in. (92 mm x 92 mm) cutout. No other holes are required.

Remove the U bracket from the housing by removing the two mounting screws from the rear of the controller housing. Slip the control through the cutout from the front of the panel and replace the U bracket. Tighten bracket screws until the controller is secure in its cutout. **Do not** over tighten these screws.

Mount the 3137-0405 or 3137-0406 power units, used with triac driver output module, to a large metal surface within the control panel. The fins must be oriented perpendicular to ground level for best heat radiation.

Power Wiring

Wire in accordance with the wiring diagrams shown for your specific output module.

Make all wiring connections in accordance with the National Electrical Code and local regulations. Use N.E.C. Class 1 wiring for all power terminals. Use No. 14 AWG copper conductors only.

Grounding of the control is not required.

It is advisable to fuse the incoming power line to terminal 8 with a type 3AG or MDL, ½A SLO-BLO fuse. Be sure that it fuses the instrument power input only and not the load also.

For all output modules, other than relay, output terminals may be wired with No. 20 AWG copper conductors only. Use No. 14 AWG for relay output terminals.

Input Wiring

Do not run thermocouple or other input wiring in the same conduit as power leads. Use only the type of thermocouple or RTD probe for which the control has been programmed. The type may be viewed by stepping through the menu using the Index key pad. Voltage or current input values are shown on the serial number label inside the instrument.

For thermocouple input, always use extension leads of the type designated for your thermocouple. Generally, the red wire from the thermocouple is *negative*.

On thermocouple input units, do not remove reference junction compensator assembly connected under terminals 15 and 16 by a tab terminal and red wire.

Input Selection

Where displays are shown in these instructions, a heavy line at the top indicates the upper display, while a heavy line at the bottom indicates the lower display.

Inputs appear as follows:

Temperature:

Upper display —

= Iron/Constantan

= Chromel/Alumel

= Chromel/Constantan

= Plat. 8% RH./Plat. 30% RH.

= W 5% RE/W 26% RE

= NiCroSil/NiSiI

= Copper/Constantan

= Plat. 13% RH./Plat.

= Plat. 10% RH. /Plat.

= PLT. 100 OHM .00392 N.B.S. Curve RTD

= NICKEL 120 OHM RTD

= PLT. 100 OHM .00395 DIN curve RTD

Lower display—

= Input

Voltage and Current:

Almost any Linear Scale may be programmed by the user (including decimal point positioning).

The scale range must fall within a 4000 or less count range. The term "count" in this case means the amount of numbers that can be displayed regardless of the position of the decimal point.

For example; 0 to 4000, -2000 to +2000, -10.0 to 390.0,

1.000 to 5.000 and 30.00 to 70.00 are all at the 4000 count maximum.

The minimum value for any range must be 100 counts or more.

For example; -50 to +50, 0 to 100, 2.5 to 12.5, .50 to 1.50 and -.010 to .090 are all at the 100 count minimum.

If the scale low value **SCALE** and the scale high value **SCRH** are greater than 4000 counts or less than 100 counts, then, either **ERR** **SCALE** or **ERR** **SCRH** will show up on the display, depending on which one is presently being programmed (opposite one shows the error).

Examples of typical programming for **SCALE** & **SCRH** for various scale ranges are;

SCALE RANGE	SCALE VALUE	SCRH VALUE
-350 +999	-350	999
-67 +113	-67	113
	or -67.0	113.0
-2 +0	-2.00	0
	or -2.000	0.000
-0.1 +0.4	-.100	.400
0 +15,000	0	150 (×100)
	or 0	1500 (×10)

All standard ranges may be programmed for 0 suppression (**0SUP**) (20% range elevation) by the user for Process Signals.

INPUT FOR STANDARD RANGES	INPUT FOR 0 SUPPRESSION PROGRAMMED 0SUP	INPUT IMPEDANCE
0 to 1 MA	0.2 to 1 MA	100 ohms
0 to 5 MA	1 to 5 MA	20 ohms
0 to 20 MA	4 to 20 MA	5 ohms
0 to 50 MA	10 to 50 MA	2 ohms
0 to 10 MV	2 to 10 MV	10K ohms
0 to 20 MV	4 to 20 MV	10K ohms
0 to 50 MV	10 to 50 MV	10K ohms
0 to 100 MV	20 to 100 MV	10K ohms
0 to 250 MV	50 to 250 MV	10K ohms
0 to 500 MV	100 to 500 MV	10K ohms
0 to 1 V	0.2 to 1 V	20K ohms
0 to 5 V	1 to 5 V	100K ohms
0 to 10 V	2 to 10 V	200K ohms
>10	USE 10 V RANGE & EXTERNAL VOLTAGE DIVIDER	

°F and °C descriptors as well as no descriptors at all may be programmed by the user. A multiple Engineering Units Label Card is provided with each instrument. The card has labels of the most common Engineering Units on it as well as blanks to create your own. The appropriate label is applied to the upper R.H. corner of the silver area opposite "SET POINT/INDEX" on the front of the instrument.

Overflow and Underflow protection may be manipulated by the user to protect from 1.) A shorted input line, 2.) Suppressed range inputs which require some time before entering the instrument scale range and 3.) Potential runaway input conditions (like overrange) and other time related input fault conditions (See "Diagnostic Error Messages").

RELAY OUTPUT MODULE (CODE 1) EXTERNAL WIRING

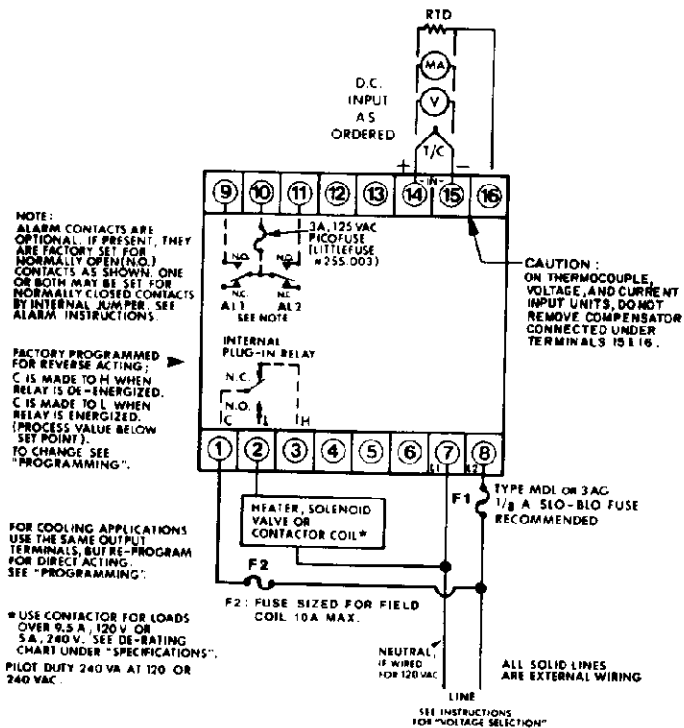

TRIAC DRIVER MODULE (CODE 2) EXTERNAL WIRING

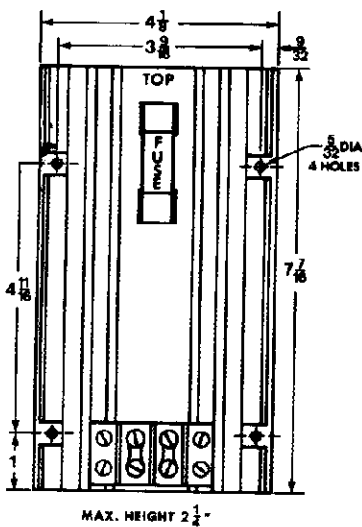
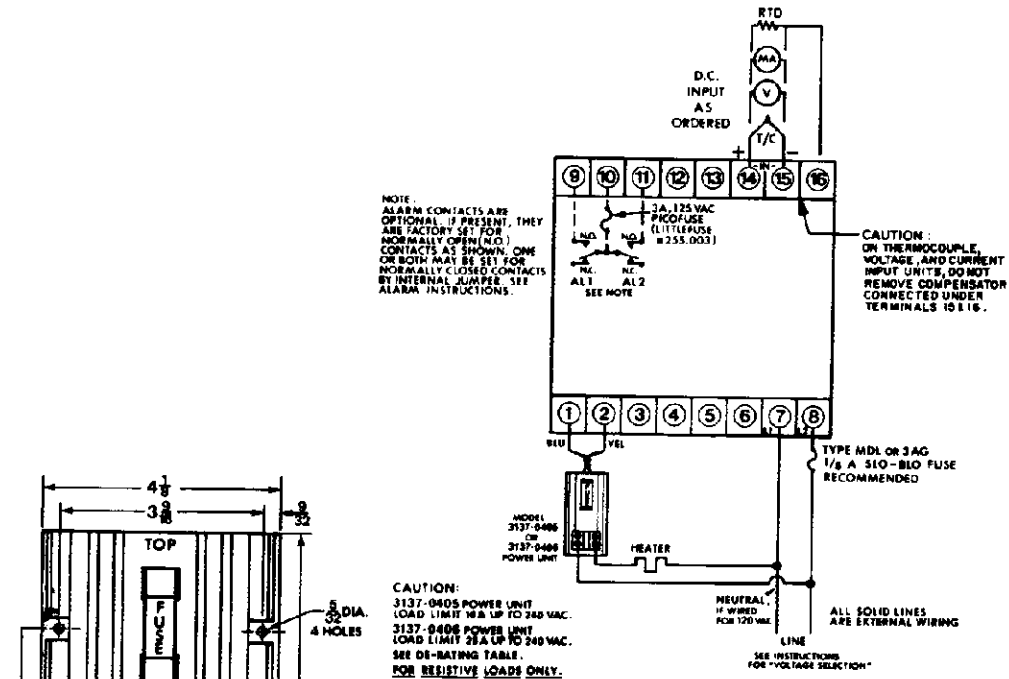

DE-RATING TABLE

AMBIENT °C	AMBIENT °F	3137-0405	3137-0406
25	77	10A.	28A.
40	104	10A.	25A.
44.4	112	9.5.	24A.
48.9	120	8.5	21.5
55	131	7.7A.	18.5

**24 VDC VOLTAGE SWITCH MODULE (CODE 3)
EXTERNAL WIRING**

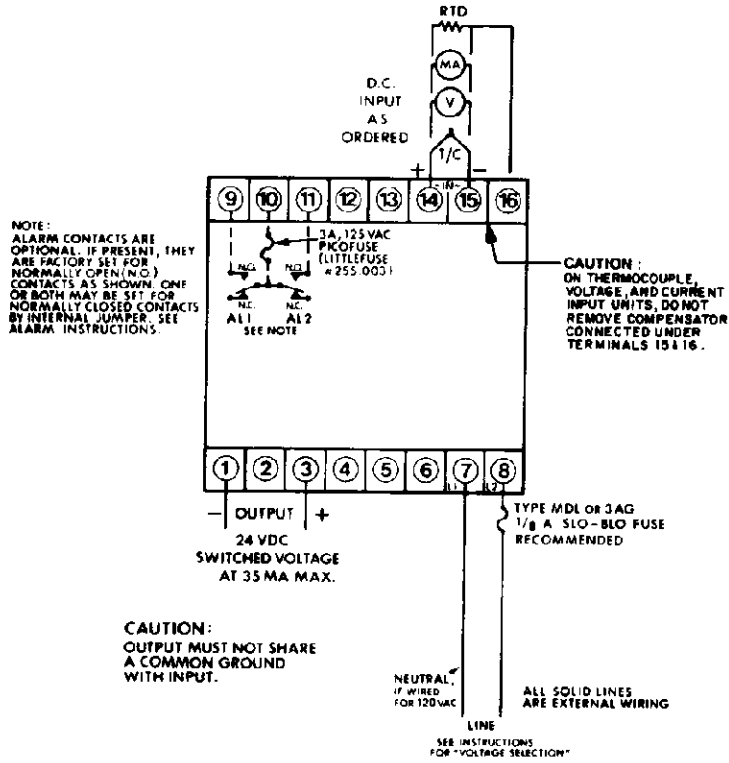

**PROPORTIONAL CURRENT OUTPUT MODULE
(CODE 4, NON-ISOLATED OR CODE 6, ISOLATED)
EXTERNAL WIRING**

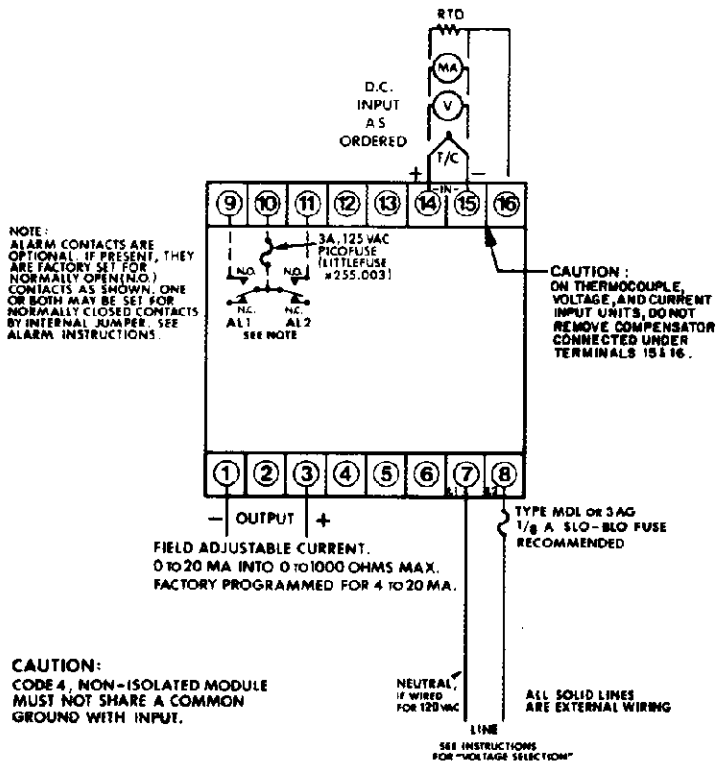

**PROPORTIONAL VOLTAGE OUTPUT MODULE
(CODE 5, NON-ISOLATED OR CODE 7, ISOLATED)
EXTERNAL WIRING**

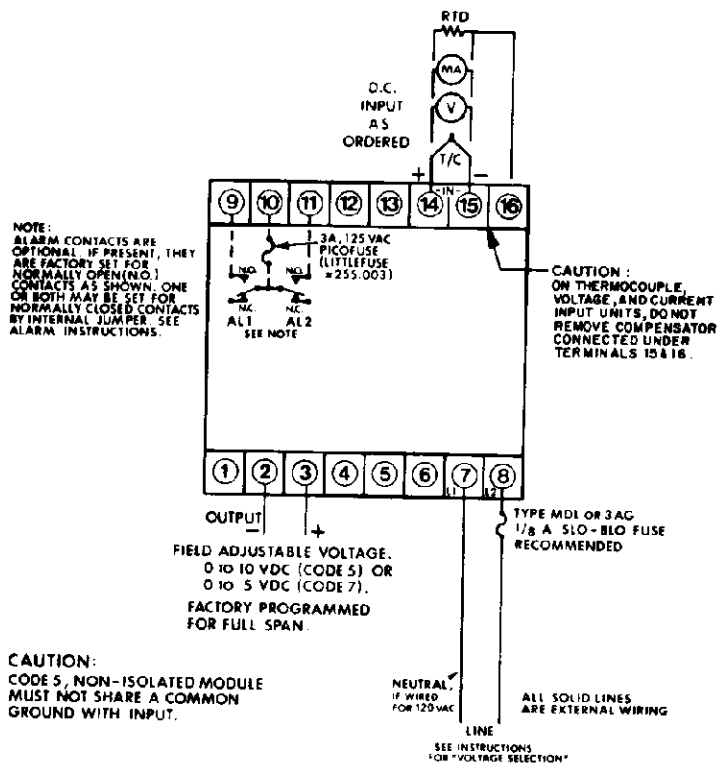

**1.0 A TRIAC SOLID STATE SWITCH MODULE (CODE 8)
EXTERNAL WIRING**

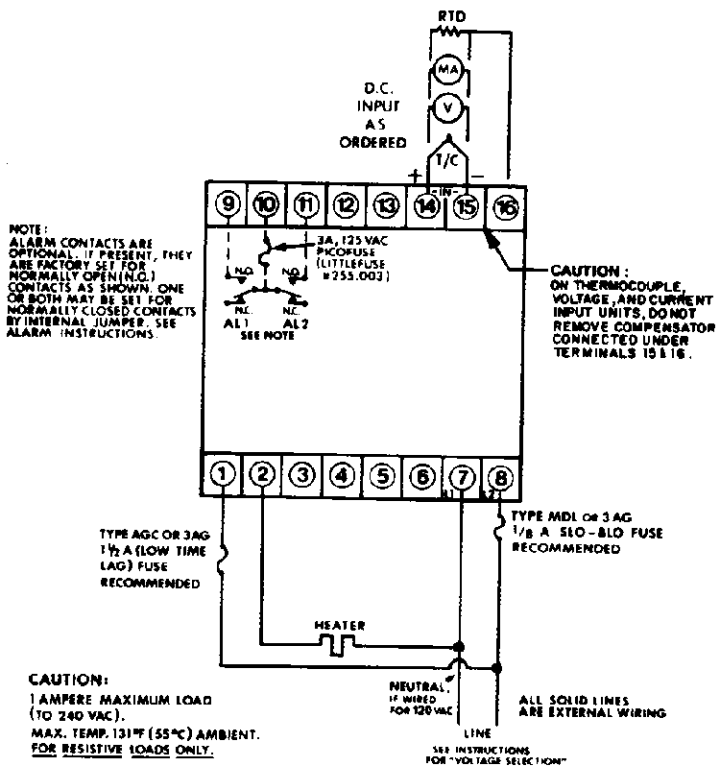

The Security Switch

The security switch allows the user to limit the changes that may be made while the control is in operation. This will help prevent unauthorized personnel from changing important settings.

The security switch allows three conditions to be selected.

1. Set-up: Allows all programmable functions to be viewed and changed.
2. Level 1: Allows changes to control set points, alarm set points and cycle rate (if time proportioning). The following may be viewed, but *not* changed: output type, lowest set point value, highest set point value, lowest output available (in percent), highest output available (in percent) and T/C or RTD type.
3. Level 2: No changes may be made. The following may be viewed: all control and alarm set points, cycle rate (if time proportioning), output type, lowest and highest set point value, lowest and highest output available (in percent) and T/C or RTD type.

The security switch is located inside the controller. It is set for security level 1 as shipped from the factory. To change the setting, remove the control from its housing as described under "Removal from the Housing". The switch is mounted on the right hand side of the processor printed circuit board near the front of the instrument.

Looking from the rear of the control, look between the upper and lower PCBs to the right of the transformer. The switch has three slide actuators as shown below:

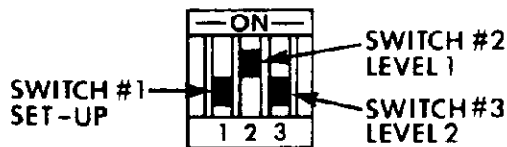

Select the slide actuator for the security condition desired. With a small screw driver move the selected slide actuator to the ON (up) position. Move the other slide actuators to the OFF (down) position. If two or more slide actuators are left in the ON position, security will be set for the lowest position. If all slide actuators are left in the OFF position, **ERR** **EEEE** will appear on the displays upon power up.

See the section "Programming in the Set-up Mode" for further instructions for the Set-up Mode.

Operation Common to All Models

In showing what the displays may indicate in these instructions, a heavy line at the top of the displayed item means that it appears on the upper display ; heavy line at the bottom, the lower display .



After mounting and wiring, power the system. All lamps and display segments come on, for 2 seconds for a lamp test for visual test to determine if they are all operative. Turn off, then on, if more time is needed. Then **SETP** **EEEE** is displayed, indicating that an internal diagnostic test is taking place. If **ERR** **EEEE** is then displayed, service and/or recalibration is required. Outputs remain off during this time. When the control passes the diagnostic test, the displays will then indicate both the process value and the set value. If the security switch is in the level 1 condition (as shipped from the factory) or in the level 2 condition, the outputs will be active. If left in the set-up condition, the outputs will remain off.

For all instructions following, other than under "Programming in the Set-up Mode", it is assumed that the security switch is in the level 1 condition.

When the displays indicate the process and set point values respectively, that is considered to be "home" position.

Press the "Index" key pad each time to advance through the various programmable or viewable parameters for a particular security condition.

When stepping through the various "Index" positions, if no keys are pressed for 4 to 5 seconds, the displays will revert to "Home" position. This can be defeated by keeping either the "Index" or "Enter" key pad depressed.

The "Increment"  key pad is used to raise a setting. The "Decrement"  key pad is used to lower a setting. They both operate at a variable speed to allow rapid setting. Settings change faster as the key is depressed longer. These keys are also used to turn certain functions on or off or to choose any one of many conditions for certain functions. This would be done while programming.

The "Index"  and "Decrement"  key pads are also used to manually reset an alarm. See "Alarm Operation".

No settings will be entered into memory without depressing the "Enter"  key pad. The previous setting will be retained if not entered. The outputs are not disturbed unless a new setting is entered. Pressing the "Enter" key will cause the displays to momentarily blank, indicating that the new data has been entered into memory.

Before adjusting for the PID control functions, refer to "PID Tuning Procedure (Quick Method)" and/or "PID Tuning Procedure (Exact Method)". If reset (integral) is to be turned off, see PD4 of "Programming in the Set-Up mode."

If thermocouple short protection is desired, see "Set-up for T/C Short Protection."

Electrical Noise

The Love Model 300 Series controls have been designed with a high level of electrical noise immunity. As with any microprocessor based device, however, excessive noise levels can interfere with proper operation.

A common source of electrical noise is generated by the field coils of contactors and solenoids. Where external contactors (mechanical or mercury) or solenoids are used in Load circuits, it is recommended that an R/C Snubber Network (Love part number 2481-00-2400) be used to suppress the noise spikes generated by the field coils. The Snubber installs easily, directly across the coil terminals.

There may be other sources of electrical noise that could affect your system. These include lightning, line faults, power switching, motors, motor controllers, or other SCR devices. To protect your system from this type of interference use a Love Line Cure™ as described in Bulletin 9490. Consult your local representative or the factory for more details.

Using Self-Tune®

The user has the choice of selecting either Self-Tune® or manual PID tune.

If manual PID is selected, follow the tuning procedures on page 11 or 12.

Love's Self-Tune® is a continuously active function that changes the P, I and D parameters as the control sees the process change. The system's performance is monitored through the process input and changes made as necessary to keep the system running smoothly. If the information received is incorrect, the control output can be seriously affected. It is therefore necessary to avoid certain conditions that would detract from the performance of the control if the Self-Tune® mode has been selected.

- 1.) Never turn off power to the heaters without turning off the power to the control as this will cause the control to tune to a condition that does not exist.

- 2.) The set point must be at least 50° F above ambient for start up with no loss of power or turn-off while approaching the set point on the first time rise to set point.
- 3.) In multi-zone applications for first time warm up, all zones should warm up simultaneously because of the influence of adjoining zones.
- 4.) If items 2 or 3 above are not possible, then select suitable values of P, I and D and switch to Self-Tune® after selection.







Any of the above conditions can cause the control to learn (and try to control) a process using the wrong PID values so that in normal operation the control will take a long time to return to the correct values.

There are other types of processes that may require special handling. If you have questions about your particular application, consult your local representative or the Factory.





The control must be in the Start Learn mode during the initial heat up of the process. If you bench test the control before installation, or if you are moving the control to a new process, be sure to put the control in Start Learn (see Condition PD 6 under "Programming in the Set-up Mode").

If Self-Tune® is initially selected, the PID settings may be read out by selecting the manual PID mode. Any of the parameters may then be changed. If Self-Tune® is later initiated, it will start with the manually selected settings.

PID Tuning Procedure (Quick Method)

Index	Initial Settings		
	Slow Response System	Medium Response System	Fast Response System
 Prop Band	12	8	6
 Reset	20.0	7.0	3.0
 Rate	1.67	0.58	0.25
Output	 = 15	 = 10	 = 6

Fine tuning the initial settings:

- 1) Increase  and/or decrease  if temperature excursions are greater than desired.
- 2) Decrease reset  time (in steps) for best (quickest) response when returning to the set point. If temperature excursions begin to show up at the set point, then, reset time is too fast (increase reset time).
- 3) Rate  time should be approximately 1/12 of the reset time. If the process hesitates when returning to the set point, then, decrease the rate time slightly (in steps) until little or no hesitation is discernable.

PID Tuning Procedure (Exact Method)

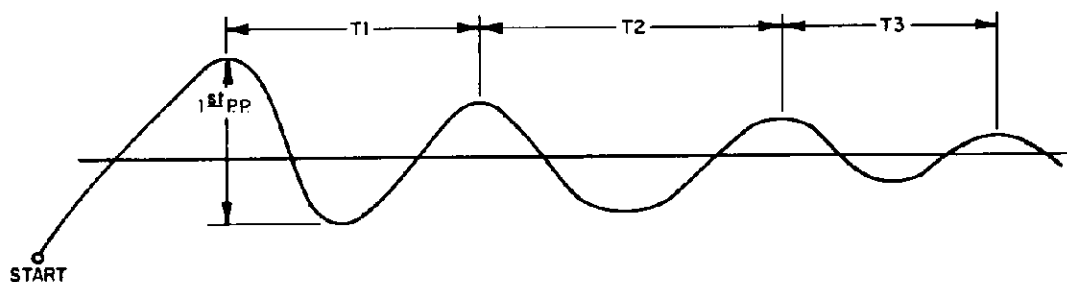

Fig. 1-Use 3 or more excursions in step 2.

- 1.) In Set-up Mode:
 - A.) Set Reset & Rate functions to Off.
 - B.) Set Control Output to On/Off. Set SP1d to -2.
- 2.) Obtain Heating Data (in Lev 1). Refer to Fig. 1:
 - A.) Start at least 20 degrees below the Set Point. Record Excursions & Time.
 - B.) Measure the 1st P.P. cycle excursion = Nom. Pb. =
 - C.) Measure T1, T2, T3, etc.;

T1= T2= T3=

Rt min. = Lowest of T1 or T2 or T3=

Rt max. = Highest of T1 or T2 or T3=
- 3.) Calculate P I D Settings:
 - A.) $Pb = \text{Nom. Pb} \times 1.1 =$
 - B.) Start with Reset = $Rt \text{ max} \times 2 =$
 - C.) Rate = $Rt \text{ max.}/8 =$
 - D.) Enter the Pb, Reset & Rate values previously calculated into the Controller & start the process.

Fine Tuning The PID Values

- 4.) Increase Pb if Temperature Excursions are greater than desired.
- 5.) Decrease Reset time (changing Rate = $\text{New Reset Time}/8$ each time) for best response when returning to the Set Point. Reset should not be less than Rt min. calculated in Step 2. If the Process Value hesitates when returning to the Set Point, then, decrease the Rate time slightly until little or no hesitation is discernable.

Programmable Functions

The programmable functions in your control are as outlined in the following chart. Normal factory programming for a particular output module is as shown in the chart. If it is satisfactory, no programming change is necessary. If programming must be changed or if a different output module is installed, see "Programming".

All instructions following, for each type of output module, assumes factory programming.

Programmable Functions Chart

Outputs	Output Module Ordered									
	Relay		Triac Driver		24 V.D.C.		Proportional Current		Proportional Voltage	
	Can Be Programmed For	Normal Factory Program	Can Be Programmed For	Normal Factory Program	Can Be Programmed For	Normal Factory Program	Can Be Programmed For	Normal Factory Program	Can Be Programmed For	Normal Factory Program
On-Off	✓		✓		✓					
On-Off Differential (if On-Off)	✓		✓		✓					
Time Proportioning (Slow) Cycle Rate Adjustable 2 to 80 sec.	✓	10 sec.	✓		✓	10 sec.				
Pulse	✓		✓		✓					
Pulse Rate (if Pulse) Adjustable 1 to 7	✓		✓		✓					
Fast Triac			✓	✓	✓	✓				
Current Proportional							✓	✓		
Voltage Proportional									✓	✓
Set Point Minimum Setting	✓	Min.	✓	Min.	✓	Min.	✓	Min.	✓	Min.
Set Point Maximum Setting	✓	Max.	✓	Max.	✓	Max.	✓	Max.	✓	Max.
Output	Reverse Acting	✓	✓	✓	✓	✓	✓	✓	✓	✓
	Direct Acting	✓		✓		✓		✓		✓
Output Adjustment Minimum 0 to 90%	✓	0%	✓	0%	✓	0%	✓	20% (4 mA.)	✓	0% 0 V.D.C.
Output Adjustment Maximum 10 to 100%	✓	100%	✓	100%	✓	100%	✓	100% (20 mA.)	✓	100% **
Set Point Status Light	Lit When Output Is "On"	✓	✓	✓	✓	✓	✓	✓	✓	✓
	Lit When Output Is "Off"	✓		✓		✓		✓		✓

**For non-isolated proportional voltage output modules, "output adjustment maximum" is factory set for 100% (10 V.D.C.); for isolated, 100% (5 V.D.C.)

Operational Suggestions and Hints

1. If thermocouple short protection is desired, see "Set-up for T/C Short Protection".
2. If input correction is desired, see "Set-up for Input Correction".
3. For Relay or 24 V.D.C. output modules, start with a cycle rate \boxed{CYI} at $\boxed{10}$ seconds. Vary the cycle rate faster $\boxed{10} \rightarrow \boxed{2}$ seconds if control excursion is greater than 4° around the set value. Cycle rate can be slower $\boxed{10} \rightarrow \boxed{80}$ seconds if control excursion is less than 2° around the set value.
4. For Current or Voltage output modules, "Set point 1 Output Low" end $\boxed{5:OL}$ and "Set point 1 Output High" end $\boxed{5:OH}$ may be changed as required, but, when changed, will not go over the complete range which may be desired. For example: controller initially "Set up" for $\boxed{5:OL} = \boxed{20}$ percent, $\boxed{5:OH} = \boxed{100}$ percent for a 4 to 20 mA output range. $\boxed{5:OL}$ is later changed to $\boxed{25}$ and $\boxed{5:OH}$ changed to $\boxed{90}$ now represents a 5 to 18 mA range. See " $\boxed{5:OL}$ and $\boxed{5:OH}$ Selection".
5. For Relay, 24 V.D.C. or Triac Driver output modules, leave $\boxed{5:OL}$ at $\boxed{0}$ and $\boxed{5:OH}$ at $\boxed{100} \rightarrow \boxed{102}$ until sure that changing these values is necessary.

Operation With Relay or 24 V.D.C. Voltage Switch Module

Read instructions given under "Operation Common to All Models".

Depress "Index" key pad. $\boxed{###} \boxed{SP1}$ appears on displays. The control set point may now be changed using the "Increment" $\boxed{\Delta}$ or "Decrement" $\boxed{\nabla_{AL}}$ key pads. When the desired set point is reached, depress "Enter" to retain.

Depress "Index" key pad. If alarms are in your model, $\boxed{###} \boxed{RL1}$ will be indicated and the alarm 1 set point may be set in the same manner as for the control set point. Be sure to depress "Enter" after the set point has been selected.

Depress "Index" key pad. $\boxed{###} \boxed{RL2}$ indication allows selection of alarm 2 set point. Be sure to read the instructions given under "Alarm Operation".

Depress "Index". Select $\boxed{SEIF} \boxed{LONL}$ or $\boxed{P.d} \boxed{LONL}$ by depressing $\boxed{\Delta}$ or $\boxed{\nabla_{AL}}$ respectively. Depress "Enter" to retain. If $\boxed{P.d} \boxed{LONL}$ is selected, set \boxed{PB} , \boxed{RES} and \boxed{RDE} to desired settings.

Depress "Index". $\boxed{\#} \boxed{PB}$ proportional band adjustable from 6 to 1000 deg. F (or equivalent deg. C) for temp inputs or 6 to 4000 counts for current or voltage inputs. Depress "Enter" to retain.

Depress "Index" $\boxed{###} \boxed{RES}$ reset (integral) adjustable 0.1 to 99.9 minutes in 6 second (0.1 minute) increments or \boxed{OFF} turns off the reset function and $\boxed{###} \boxed{OFF}$ appears and can be adjusted from 0.1 to 99.9% of proportional band at the set point. If $\boxed{OFF} \boxed{OFF}$ is selected, then displays return to $\boxed{###} \boxed{RES}$ and a reset value must be selected. Depress "Enter" to retain.

Depress "Index" $\boxed{###} \boxed{RDE}$ rate (derivative) adjustable 0.01 to 99.99 minutes in 0.6 second (0.01 minute) increments or \boxed{OFF} turns off the rate function. Press "Enter" to retain.

Depress "Index". $\boxed{10} \boxed{CYI}$ indicates time proportioning cycle rate in seconds. This is adjustable from 2 to 80 seconds in 2 second intervals. The time set is total time of on time plus off time at 50% duty cycle (equal on-off times). Setting too short a time will wear out mechanical contactors, while too long a time may cause process cycling around the set point. A setting of 10 seconds or more is good for contactors. Where operating directly into heating loads a shorter time can be considered but may reduce the life of the relay module. The 24 V.D.C. module can be cycled as fast as can be set.

Depress "Index". ##### **SP_L** is displayed. This indicates the lowest set value that may be set for any settable function like control set point or alarm settings. This cannot be set in level 1. It may only be viewed.

Depress "Index". ##### **SP_H** is displayed. The highest set value that may be set. Viewed only.

Depress "Index". **0** **SP_L** is shown, indicating the lowest output (in percent) available. This cannot be set in level 1. It may be viewed only.

Depress "Index". **100** **SP_H** is displayed. The highest output (in percent) available. Viewed only.

Depress "Index." **U-IL** **inP** indicates input calibration. See "Input Wiring" for designations of various input calibrations. This cannot be changed in level 1. It may be viewed only.

For temperature ranges, the °F/°C descriptor alongside the upper display will indicate which temperature scale that the control is programmed for. This may be changed in the set-up condition only.

When the set point is set above the process value, the red status light will be lit, indicating that the output is energized. The heating system is now active. As the temperature rises towards the set point, the process value indicator will continue to indicate the changes taking place in the process. When the edge of the proportional band is reached, the red status light will start to alternate from on to off. This is the time proportioning action. This action continues at the set point to maintain a stable control temperature.

If your control is equipped with alarms, see "Alarm Operation".

Operation With Triac Driver Module or Triac Module

Read instructions given under "Operation Common to All Models".

Depress "Index" key pad. ##### **SP_i** appears on displays. The control set point may now be changed using the "Increment" **▲** or "Decrement" **▼_{Al}** key pads. When the desired set point is reached, depress "Enter" to retain.

Depress "Index" key pad. If alarms are in your model, ##### **AL₁** will be indicated and the alarm 1 set point may be set in the same manner as for the control set point. Be sure to depress "Enter" after the set point has been selected.

Depress "Index" key pad. ##### **AL₂** indication allows selection of alarm 2 set point. Be sure to read the instructions given under "Alarm Operation".

Depress "Index". Select **SELE** **UN_E** or **P.d** **UN_E** by depressing **▲** or **▼_{Al}** respectively. Depress "Enter" to retain. If **P.d** **UN_E** is selected, set **P_b**, **r_{ES}** and **r_{ES}** to desired setting.

Depress "Index". **#** **P_b** proportional band adjustable from 6 to 1000 deg. F (or equivalent deg. C) for temp inputs or 6 to 4000 counts for current or voltage inputs. Depress "Enter" to retain.

Depress "Index". **###** **r_{ES}** reset (integral) adjustable 0.1 to 99.9 minutes in 6 seconds (0.1 minute) increments or **OFF** turns off the reset function and **###** **OF_S** appears and can be adjusted from 0.1 to 99.9% of proportional band at the set point. If **OFF** **OF_S** is selected, then displays return to **###** **r_{ES}** and a reset value must be selected. Depress "Enter" to retain.

Depress "Index". ##### **r_{ES}** rate (derivative) adjustable 0.01 to 99.99 minutes in 0.6 second (0.01 minute) increments or **OFF** turns off the rate function. Press "Enter" to retain.

Depress "Index". **FL** **OUT** appears on the display, indicating the controller has been programmed for fast triac output (time proportioning rate as fast as 1/20 second on and 1/20 second off).

Depress "Index". **####** **SP1** is displayed. This indicates the lowest set value that may be set for any settable function like control set point or alarm settings. This cannot be set in level 1. It may only be viewed.

Depress "Index". **####** **SPH** is displayed. The highest set value that may be set. Viewed only.

Depress "Index". **0** **SO1** is shown, indicating the lowest output (in percent) available. This cannot be set in level 1. It may be viewed only.

Depress "Index". **100** **SOH** is displayed. The highest output (in percent) available. Viewed only.

Depress "Index". **U-10** **INP** indicates input calibration. See "Input Wiring" for designations of various input calibrations. This cannot be changed in level 1. It may be viewed only.

For temperature ranges, the °F/°C descriptor alongside the upper display will indicate which temperature scale that the control is programmed for. This may be changed in the set-up condition only.

With the set point set above the process value, the red status light will be lit, indicating that power is being supplied to the heaters.

As the temperature rises towards the set point, the process indicator will continue to indicate the change taking place in the process. When the edge of the proportional band is reached, the red status light will start to alternate from on to off. This is the time proportioning action. This action continues at the set point to maintain a stable control temperature.

If your control is equipped with alarms, see "Alarm Operation".

Operation With Proportional Current Output Module

Read instructions given under "Operation Common to All Models".

Depress "Index" key pad. **####** **SP1** appears on displays. The control set point may now be changed using the "Increment" **▲** or "Decrement" **▼AL** key pads. When the desired set point is reached, depress "Enter" to retain.

Depress "Index" key pad. If alarms are in your model, **####** **AL1** will be indicated and the alarm 1 set point may be set in the same manner as for the control set point. Be sure to depress "Enter" after the set point has been selected.

Depress "Index" key pad. **####** **AL2** indication allows selection of alarm 2 set point. Be sure to read the instructions given under "Alarm Operation."

Depress "Index". Select **SELF** **UNF** or **Pd** **UNF** by depressing **▲** or **▼AL** respectively. Depress "Enter" to retain. If **Pd** **UNF** is selected, set **Pb**, **RES** and **RES** to desired settings.

Depress "Index". **#** **Pb** proportional band adjustable from 6 to 1000 deg. F (or equivalent deg. C) for temp inputs or 6 to 4000 counts for current or voltage inputs. Depress "Enter" to retain.

Depress "Index". **###** **RES** reset (integral) adjustable 0.1 to 99.9 minutes in 6 second (0.1 minute) increments or **OFF** turns off the reset function and **###** **OFF** appears and can be adjusted from 0.1 to 99.9% of proportional band at the set point.

If **0FF** **0FS** is selected, then displays return to **###** **rE5** and a reset value must be selected. Depress "Enter" to retain.

Depress "Index". **###** **rEE** rate (derivative) adjustable 0.01 to 99.99 minutes in 0.6 second (0.01 minute) increments or **0FF** turns off the rate function. Press "Enter" to retain.

Depress "Index". **CP** **Out** appears on the display, indicating the controller has been programmed for proportional current output.

Depress "Index". **####** **SPL** is displayed. This indicates the lowest set value that may be set for any setable function like control set point or alarm settings. This cannot be set in level 1. It may only be viewed.

Depress "Index". **####** **SPH** is displayed. The highest set value that may be set. Viewed only.

Depress "Index". **20** **50L** is shown, indicating the lowest output (in percent) available. This cannot be set in level 1. It may be viewed only.

Depress "Index". **100** **50H** is displayed. This highest output (in percent) available. Viewed only.

Depress "Index". **W-R** **inP** indicates input calibration. See "Input Wiring" for designations of various input calibrations. This cannot be changed in level 1. It may be viewed only.

For temperature ranges, the °F/°C descriptor alongside the upper display will indicate which temperature scale that the control is programmed for. This may be changed in the set-up condition only.

With the set point set above the process value, the red status light will be lit, indicating that there is a current output signal. This light stays on as long as there is any current output at all. Since the control is programmed at the factory for 4 to 20 mA output, the red status light will always be on. If the output is re-programmed for 0 to 20 mA or any other current output starting at zero, the light would go out upon the current output signal becoming zero. If light is desired to be off with 4 to 20mA output, re-program **SPH** to **0FF** in "Set-up" mode. See "Programming in the Set-up Mode."

The current output will vary from 20mA to 4mA within the proportional band to maintain stable control.

If your control is equipped with alarms, see "Alarm Operation".

Operation With Proportional Voltage Output Module

Read instructions given under "Operation Common to All Models."

Depress "Index" key pad. **####** **SPi** appears on displays. The control set point may now be changed using the "Increment" **▲** or "Decrement" **▼** key pads. When the desired set point is reached, depress "Enter" to retain.

Depress "Index" key pad. If alarms are in your model, **####** **Ri1** will be indicated and the alarm 1 set point may be set in the same manner as for the control set point. Be sure to depress "Enter" after the set point has been selected.

Depress "Index" key pad. **####** **Ri2** indication allows selection of alarm 2 set point. Be sure to read the instructions given under "Alarm Operation".

Depress "Index". Select **SEIF** **UNL** or **P.d** **UNL** by depressing **▲** or **▼** respectively. Depress "Enter" to retain. If **P.d** **UNL** is selected, set **Pb**, **rE5** and **rEE** to desired settings.

Depress "Index". $\boxed{\#}$ \boxed{Pb} proportional band adjustable from 6 to 1000 deg. F (or equivalent deg. C) for temp inputs or 6 to 4000 counts for current or voltage inputs. Depress "Enter" to retain.

Depress "Index". $\boxed{###}$ $\boxed{r\int S}$ reset (integral) adjustable 0.1 to 99.9 minutes in 6 second (0.1 minute) increments or \boxed{OFF} turns off the reset function and $\boxed{###}$ \boxed{Pb} appears and can be adjusted from 0.1 to 99.9% of proportional band at the set point. If \boxed{OFF} \boxed{Pb} is selected, then displays return to $\boxed{###}$ $\boxed{r\int S}$ and a reset value must be selected. Depress "Enter" to retain.

Depress "Index". $\boxed{###}$ $\boxed{r\dot{E}}$ rate (derivative) adjustable 0.01 to 99.99 minutes in 0.6 second (0.01 minute) increments or \boxed{OFF} turns off the rate function. Press "Enter" to retain.

Depress "Index". \boxed{EP} $\boxed{OUT?}$ appears on the display, indicating the controller has been programmed for proportional voltage output.

Depress "Index". $\boxed{###}$ $\boxed{SP\downarrow}$ is displayed. This indicates the lowest set value that may be set for any settable function like control set point or alarm settings. This cannot be set in level 1. It may only be viewed.

Depress "Index". $\boxed{###}$ $\boxed{SP\uparrow}$ is displayed. The highest set value that may be set. Viewed only.

Depress "Index". $\boxed{0}$ $\boxed{S\downarrow 0\%}$ is shown, indicating the lowest output (in percent) available. This cannot be set in level 1. It may be viewed only.

Depress "Index". $\boxed{100}$ $\boxed{S\uparrow 100\%}$ is displayed. The highest output (in percent) available. Viewed only.

Depress "Index". $\boxed{I\downarrow IL}$ \boxed{INP} indicates input calibration. See "Input Wiring" for designations of various input calibrations. This cannot be changed in level 1. It may be viewed only.

For temperature ranges, the °F/°C descriptor alongside the upper display will indicate which temperature scale that the control is programmed for. This may be changed in the set-up condition only.

With the set point set above the process value, the red status light will be lit, indicating that there is a voltage output signal. This light stays on as long as there is any voltage output at all. The voltage output control is programmed at the factory for 0 to 10 V.D.C. for non-isolated modules and 0 to 5 V.D.C. for isolated modules. Therefore the red status light will go out when the output voltage is zero. If re-programmed to an output range starting above zero, such as, 1 to 5 V.D.C., the light will never go out. If light is desired to be off with output ranges starting above zero, re-program $\boxed{SP\downarrow}$ to \boxed{OFF} in "Set-up" mode. See "Programming in the Set-up Mode".

The voltage output will vary over its range within the proportional band to maintain stable control.

If your control is equipped with alarms, see "Alarm Operation".

Alarm Operation and Alarm Programmable Functions

If your control is equipped with alarms, they may be programmed for various types of operation as described in the following chart. Normal factory programming is as shown in the chart. If it is satisfactory, no programming change is necessary. If programming must be changed, see "Programming in the Set-up Mode".

CAUTION: In any critical application where failure could cause expensive product loss or endanger personal safety, a second redundant limit controller is recommended.

Programmable Functions for Alarms

Alarms [Optional]

Programmable Items		Alarm 1		Alarm 2	
		Can Be Programmed For	Normal Factory Program	Can Be Programmed For	Normal Factory Program
Alarm Type (Both Alarms Must Be Same Type)	Absolute (Non-Tracking)	✓	✓	✓	✓
	Deviation (Tracking)	✓		✓	
Alarm Reset	Automatic	✓	✓	✓	✓
	Manual	✓		✓	
Alarm Action	Reverse Acting (Low Alarm)	✓	✓	✓	
	Direct Acting (High Alarm)	✓		✓	✓
Alarm Power Interrupt Circuit	Off	✓	✓	✓	✓
	On	✓		✓	
Alarm Status Lights	Lit When Alarm Output Is "On"	✓		✓	✓
	Lit When Alarm Output Is "Off"	✓		✓	
Alarm Light Behavior	Flashing	✓	✓	✓	✓
	Steady	✓		✓	
Alarm Output Contacts (Selected by Internal Jumper)	Normally Open with No Power	✓	✓	✓	✓
	Normally Closed With No Power	✓		✓	

When programmed for manual alarm reset, the "Index" and "Decrement" key pads act as a manual reset switch when both are depressed at the same time.

Reset will occur only if there is no alarm condition.

Alarm output contacts may be re-programmed for normally closed operation (one or both) by internal jumper.

To change the jumper position, remove the control from its housing as described under "Removal from the Housing". On the left side of the upper PCB, as viewed from the rear, near the rear terminals, the AL1 and AL2 jumpers can be seen. See sketch below. There are three posts in the PCB for each jumper. The center post is common. The outer posts are marked N.O. (normally open) and N.C. (normally closed). Change the jumper position by pulling it straight up from the PCB and off the posts. Replace it in the desired position by pushing it over the posts.

As received from the factory, the control is programmed for absolute (non-tracking) alarms. When setting the alarm set point, set for the process value where an alarm must be initiated.

If programmed for deviation (tracking) alarms, set the alarm set points for the deviation from set value. Example: high alarm point, +5, +10, +15, or other value; low alarm, -5, -10, -15, or other value; 0 represents the same set value as SPI (main set point). If SPI is changed, the alarms will continue to hold the same relationship as originally set.

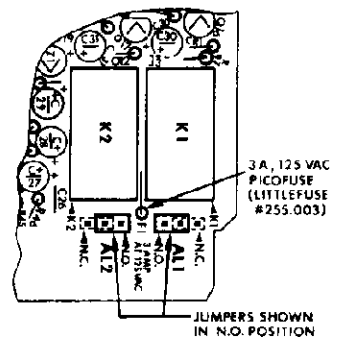

Options

Option 520. Factory Programming. Set-up menu pre-programmed to customer specifications instead of the standard factory programs as outlined in the "Programmable Functions Chart". Program may be checked by placing the security switch in the set-up condition and stepping through each "Index" position.

Option 550. Isolated Power Supply. This option *must* be present in the control when Isolated Current Output Module 3308-145 or Isolated Voltage Output Module 3308-155 is used. Other modules may also be used with this option.

Option 617. Rear Terminal Enclosure. The enclosure may be used to simply cover the rear terminals or to surface mount the controller. To mount the enclosure to the controller, follow the instructions packaged with the enclosure.

Option 6156. Splash and Dust Resistant Construction. Consists of a gasketed splash resistant cover which snaps over the bezel, a gasket between the bezel and housing and a gasket between the housing and customer panel. Follow the instructions packaged with the cover.

Option 6162. Tamper Resistant Cover. Similar to Option 6156, except screws are provided (top and bottom) that lock into two blind holes in the instrument bezel. The instrument must be supplied with these holes. See Option 6166 below. Gasketed cover only. No extra gaskets provided. Follow the instructions packaged with the cover.

Option 6166. Blind Holes for Option 6162. Blind holes are provided in the instrument bezel to accept the tamper resistant cover.

Other Options

For other options, see separate instruction sheet furnished if that option was ordered.

Specifications

Input: Thermocouple, RTD, current or voltage.

Input Impedance: 15 megohms minimum.

Accuracy: $\pm 0.25\%$ of span ± 1 least significant digit.

Resolution: 1 or 0.1 degree.

Process Capability: Unique algorithms for controlling extremely slow to extremely fast processes.

Line Voltage Stability: $+10\%$, -15% change in line voltage from nominal will not shift the control point by more than 0.05% of span.

Temperature Stability: $3 \mu\text{V}/^\circ\text{C}$ typical, $6 \mu\text{V}/^\circ\text{C}$ maximum.

Maximum Thermocouple Resistance: 1000 ohms. 200 ohms equals less than $\pm 0.1\%$ of span error.

Humidity Conditions: 0 to 90% up to 40°C non-condensing. 10 to 50% at 55°C non-condensing.

Common Mode Rejection: 140 DB minimum at 60 Hz.

Normal Mode Rejection: 65 DB typical, 60 DB minimum at 60 Hz.

Supply Voltage: 120/208/240/V.A.C., 50/60 Hz by jumper selection.

Power Consumption: 10 V.A. nominal.

Ambient Temperature Range: 0 to 55°C (32 to 130°F).

Storage Temperature: -40 to $+80^\circ\text{C}$ (-40 to $+175^\circ\text{F}$).

Displays: 0.56" high LED displays indicate Process Value/Set Point or Index value/Index.

Display Update: Greater than 10 times per second.

Status Lights: All output, descriptor and alarm conditions are indicated. Output and descriptors by red LED's, alarm conditions by yellow LED's.

Backup: Non-volatile memory. No batteries required.

Input Protection: Outputs turn off and error message appears on the display for either open or shorted sensor input and for either over or under range current or voltage inputs.

Other Protection: Error messages are displayed also for the following reasons: self diagnostic test has failed, internal reference is out of specification, pre-set set point limits have been exceeded, ambient temperature at the control is out of the specification range or process heater is inoperative (T/C input only).

Diagnostics: Self-check, display and lamp test and full array of error messages.

Programmability: See programmable functions chart.

Control Functions:

P.I.D.: Proportional, integral (reset) and derivative (rate).

Cycle Rate: Adjustable, 2 to 80 seconds full time of on time plus off time at 50% duty cycle (equal on and off times). In the time proportioning mode only.

On-Off Differential: Adjustable, from 2° to full scale in 1° steps or 0.5° to 999.0° in 0.1° steps. In the on-off mode only.

Pulse Rate: Adjustable pulse rate in 7 steps. In the pulse mode only.

Output Modules:

Relay: Plug-in, 9.5A (120 V.A.C.) up to 30 °C ambient, de-rated to 8.0A at 55°C. Also 5.0 A (240 V.A.C.) up to 55°C. Ratings are for resistive loads. Pilot duty, 240 V.A. at 120 or 240 V.A.C. Relay output contacts are single pole, double throw.

Relay de-rating chart for 120 V.A.C. loads is shown below. For 240 V.A.C. loads, current rating is 5A to 55°C (131°F).

Ambient °C	Ambient °F	Current Rating Amperes
Up to 30	Up to 86	9.5
35	95	9.2
40	104	8.9
45	113	8.6
50	122	8.3
55 max.	131 max.	8.0

Triac Driver: Solid state switch rated at 0.1 A to drive external power units 3137-0405 and 3137-0406.

24 V.D.C. Voltage Switch: Supplies 24 V.D.C. @ 35 mA max. to drive solid state contactors.

Proportional Current, Non-Isolated: 0 to 20.4 mA into 0 to 1000 ohms max. Span programmable through front panel key pads, such as 4 to 20 mA, 1 to 5 mA, 2 to 12 mA, etc. Control input must not share common grounds with the output.

Proportional Current, Isolated: Same as the non-isolated, except that control inputs may share common grounds with the output.

Proportional Voltage, Non-Isolated: 0 to 10.2 V.D.C. at 20 mA max. (500 ohms min.). Span programmable through front panel key pads, such as 0 to 1 V.D.C., 1 to 5 V.D.C., 4 to 7 V.D.C., 0 to 5 V.D.C., etc. Control input must not share common grounds with the output.

Proportional Voltage, Isolated: 0 to 5.1 V.D.C. at 20 mA max. (250 ohms min.). Span programmable through front panel key pads, such as 0 to 1 V.D.C., 1 to 5 V.D.C., 0 to 5 V.D.C., etc.

Triac Solid State Switch: Rated at 1.0 A, 240 VAC max. (resistive). Not used to drive contactors or SSR's.

Alarms: Two optional. Full selection of alarm actions.

Alarm Relays: 1.0 A at 120 V.A.C. only. For resistive loads. Normally open or normally closed output contacts selected by internal jumper. Alarm relays are fused.













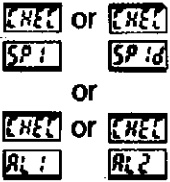



Security: Three conditions selected by internal switch.

Housing: Flame retardant U.L. rated plastic. Sealed membrane switch front panel is moisture and oil resistant. Wiring terminals are located on the rear. Full plug-in construction.

Weight: Approx. 2.5 lbs.







Diagnostic Error Messages

The 300 Series Controller will display several error messages in accordance with its diagnostics to give appropriate warning when necessary. When the chart below shows Outputs "Turned off", this means that relays are de-energized, 24 V.D.C. or triac driver modules turn off and current or voltage modules go to zero as if power was turned off.

Display	Meaning	Outputs	Action Required
	Both displays blank (unlit). Control is not getting any power or voltage supply is too low.	Turned off.	Check to make sure power supply is turned on. Check voltage selection jumper inside control (see "Voltage Selection"). Check fuses external to the control. Failure to select proper voltage to the controller can result in transformer burn-out.
	Fail test. Appears upon power up if internal diagnostics detects a failure. Failure may be circuit related or if one of the security switches is not in the "on" position. This is also displayed if, during the course of normal operation, a catastrophic event occurs. Displays flash.	Turned off.	First check to see if the security switch of your choice is "on". If it isn't, turn it on. Replacing the control back into its housing and turning the power on will reset the control. If one of the security switches is on and this message occurs, remove the controller from service.
	One or more of these messages will appear upon power up, if any of these set points or differentials are set either below or above the  or  programmed values or beyond the input range ends.  = Set point one.  = Off/On differential.  = Alarm one set point.  = Alarm two set point.	Turned off.	In the "Set-up" mode, correct  or  or  or  to be within the  or  limits or re-program  or  to be at or beyond the selected set points, but not beyond the input range. See "Programming in the Set-up Mode."

Display	Meaning	Outputs	Action Required
<div style="display: flex; flex-direction: column; align-items: center;"> <div style="display: flex; gap: 10px;"> <div style="border: 1px solid black; padding: 2px;">SPH</div> <div style="border: 1px solid black; padding: 2px;">or</div> <div style="border: 1px solid black; padding: 2px;">SPH</div> </div> <div style="display: flex; gap: 10px; margin-top: 5px;"> <div style="border: 1px solid black; padding: 2px;">SPL</div> <div style="border: 1px solid black; padding: 2px;">SPL</div> </div> </div>	<p>Check 'Set Point Low' value or check 'Set Point High' value appears upon power-up, if SPL or SPH is programmed either below or above the input range ends. See "Temperature Ranges".</p>	<p>Turned off.</p>	<p>Correct SPL or SPH by re-programming in the "Set-up" mode to within the input range. See "Programming in the Set-up Mode".</p>
<div style="display: flex; flex-direction: column; align-items: center;"> <div style="border: 1px solid black; padding: 2px; margin-bottom: 5px;">SPH</div> <div style="border: 1px solid black; padding: 2px;">SPH</div> </div>	<p>Check 'Set Point High' value. Appears when, in the "Set-up" mode, one or more of the set points, differentials or alarm points is set above the maximum value entered for SPH. It will also appear if any set point, control or alarm, is set above SPH while in security Level 1. The set point will not be accepted and the previously entered set point will be retained. The displays return to home position.</p>	<p>Turned off during "Set-up".</p> <p>Remain active in security Level 1.</p>	<p>In "Set-up", select a set point, differential or alarm point below the 'Set Point High' value or re-program SPH to a new value above the highest set point, differential or alarm point, but not beyond the input range.</p> <p>In security Level 1, select a set point or alarm point below the 'Set Point High' value or re-program SPH to a new value. See "Programming in the Set-up Mode".</p>
<div style="display: flex; flex-direction: column; align-items: center;"> <div style="border: 1px solid black; padding: 2px; margin-bottom: 5px;">SPH</div> <div style="border: 1px solid black; padding: 2px;">SPL</div> </div>	<p>Check 'Set Point Low' value. Appears when in the "Set-up" mode, one or more of the set points, differentials or alarm points is set below the minimum value entered for SPL. It will also appear if any set point, control or alarm, is set below SPL while in security Level 1. The set point will not be accepted and the previously entered set point will be retained. The displays return to home position.</p>	<p>Turned off during "Set-up".</p> <p>Remain active in security Level 1.</p>	<p>In "Set-up", select a set point, differential or alarm point above the 'Set Point Low' value or re-program SPL to a new value below the lowest set point, differential or alarm point, but not below the input range.</p> <p>In security Level 1, select a set point or alarm point above the 'Set Point Low' value or re-program SPL to a new value. See "Programming in the Set-up Mode".</p>

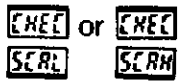
Display	Meaning	Outputs	Action Required
<p> \overline{UP} or \overline{OF} $\overline{###}$ $\overline{###}$ </p> <p>sequencing to</p> <p> \overline{bAd} \overline{inP} </p>	<p>Underflow or overflow of current or voltage input. \overline{UP} flashes under low end of zero suppressed range \overline{OSUP} or under the first 0.1% of zero start range. \overline{OF} flashes at 0.5% above the top of the range. Lower display continues to indicate the set value.</p> <p>When \overline{inPt} (input fault time) has been programmed for $\overline{0.1}$ min. (6 sec.) to $\overline{5400}$ min. (9 hrs.), then outputs will remain active until the end of this time, when, \overline{bAd} \overline{inP} will flash and outputs are turned off.</p> <p>When \overline{inPt} (input fault time) has been programmed for \overline{OFF}, then outputs remain active indefinitely.</p> <p>\overline{bAd} \overline{inP} is displayed on input polarity reversal or beyond the underflow or overflow minimal limits when \overline{inPt} has been programmed as described above. Displays flash.</p>	<p>Remain active</p> <p>Remain active to Turned off.</p> <p>Remain active</p> <p>Turned off.</p>	<p>Input signal may normally go above or below range ends. If not, check input and correct. If the condition is corrected before sequencing to bad input, the displays will go back to normal indication (home position) without further attention.</p> <p>Correct input. Turn power to the control off, then on, to reset.</p> <p>Underflow and/or overflow is normal. No action required.</p> <p>Correct input. Turn power to the control off, then on, to reset.</p>
<p> \overline{bAd} \overline{inP} </p>	<p>Bad input. RTD sensor open or shorted, T/C shorted or heater is not working. For thermocouple input $\overline{E5}$ (T/C short protection) must be turned "on" to warn of shorted T/C or heater not working. Displays flash.</p>	<p>Turned off.</p>	<p>Correct sensor or heater condition. Turn power to the control off, then on, to reset.</p>

Display	Meaning	Outputs	Action Required
	Open input T/C circuit open. For T/C input only. Displays flash.	Turned off	Correct T/C or T/C leads. Turn power to the control off, then on, to reset.
	Area appears if the controller ambient temperature nears either extreme of its specification of 0°C (32°F) or 55°C (131°F). Upper display continues to indicate the process value. Both displays flash.	Remain active	Correct ambient temperature conditions by eliminating cause (too near heated area, cabinet filters clogged, poor location, etc.). Will reset to home position when condition is corrected.
	Area appears with blank upper display if the controller ambient temperature reaches 5°C (9°F) beyond the extreme of its specification. This occurs at -5°C (23°F) or +60°C (140°F). Lower display remains steady. This condition will also occur if ambient temp compensator connected between terminals 15 and 16 is dis-connected or the wire is broken (present for all inputs except RTD).	Turned off.	Correct ambient temperature conditions by eliminating cause (too near heated area, cabinet filters clogged, poor location, etc.) or reconnect ambient temp compensator. Turn power to the control off, then on, to reset.
	Check calibration. Appears during normal operation if internal reference or associated circuitry is out of tolerance. Intermittant flashing occurs at edge of specification, alternating with home position. When over specification, display flashes continuously without alternating.	Remain active at edge of specification. Turned off when over specification.	Remove controller for service and/or recalibration.
	The difference between "Scale Low Value"  and "Scale High Value"  is programmed for greater than 4000 or less than 100 counts during programming of voltage or current input scale range.	Turned off	Program within the allowable count range.

Programming in the Set-up Mode

As an aid to programming, a blank "Programming Selection Table" is located in the back of this instruction booklet. It may be used to pre-select your program choices.



During programming, in the "Set-up" condition, all outputs will be off.





Remove the controller from its housing as described under "Removal From the Housing".

Set the security switch to "Set-up". Switch #1 "ON", switches #2 and #3 off (down) as described under "The Security Switch".

Replace the controller into its housing and power the instrument.



All lamps and display segments come on for 2 seconds for a lamp test for user examination to determine if they are all operative. Turn power off, then on, if more time is needed.

In showing what the displays may indicate in these instructions, a heavy line at the top of the displayed item means that it appears on the upper display ; heavy line at the bottom, the lower display .

  is then displayed, indicating that an internal diagnostic test is taking place. If   is then displayed, service and/or recalibration is required.

When the control passes the diagnostic test, the displays will then indicate both the process value and the set value. This is considered "home" position. The controller will return to the "home" position if no keys are pressed for 8-10 seconds. This can be defeated by holding in either the "Index" or "Enter" key pads.

Repeated actuation of the "Index" key pad advances the various programmable functions onto the displays for either viewing or changing. At each function display, if nothing is done, the controller will return to the "home" position unless the "Index" or "Enter" key pads are continually depressed as described above.

The "Increment"  key pad is used to raise a setting, turn certain functions "on" or to choose any one of many conditions for certain functions. The "Decrement" key pad  is used to lower a setting, turn certain functions "off" or to choose any of many conditions for certain functions. They both operate at a variable speed to allow rapid setting. Settings change faster as the key is depressed longer.

Index items may be presented in reverse order by depressing the "Decrement" key pad and then depressing the "Index" key pad.

No settings can be entered into memory without depressing the "Enter" key pad. The previous setting will be retained if not "Entered". When depressing the "Enter" key pad the displays will momentarily go blank, indicating that the new data has been "Entered" into memory.

Programmable data will be presented as shown in the following chart. At each step press "Enter" if you wish to retain that particular data choice that is being newly entered. If no change is desired, press "Index" to proceed to next programmable function. If the displays automatically return to the "home" position before being able to make changes, simply repeatedly depress the "Index" key until back to the function of interest.

Set Point Changes

CON- DITION	Display Reads	Change Value in Upper Display by Pressing	Comments
A.	<div style="display: flex; justify-content: space-around;"> #### SP 1 </div> Set Point #1	<div style="display: flex; justify-content: center; gap: 10px;"> ▲ or ▼ </div> Variable Speed	Press "Enter" to retain. Press "Index" to proceed to next programmable function. This function may also be changed in "level 1 security."
B.	<div style="display: flex; justify-content: space-around;"> #### Rt 1 </div> Alarm #1 Set Point (if equipped)	<div style="display: flex; justify-content: center; gap: 10px;"> ▲ or ▼ </div> Variable Speed	Press "Enter" to retain. Press "Index" to proceed to next programmable function. This function may also be changed in "level 1 security".
C.	<div style="display: flex; justify-content: space-around;"> #### Rt 2 </div> Alarm #2 Set Point (if equipped)	<div style="display: flex; justify-content: center; gap: 10px;"> ▲ or ▼ </div> Variable Speed	Press "Enter" to retain. Press "Index" to proceed to next programmable function. This function may also be changed in "level 1 security."

Programming For Self-Tune® or PID Control

CON- DITION	Display Reads	Change Value in Upper Display by Pressing	Comments
PD1.	<div style="display: flex; justify-content: space-around;"> SELF tune </div> or <div style="display: flex; justify-content: space-around;"> PID </div> Select Self-Tune® or manual tune PID	<div style="display: flex; justify-content: center; gap: 10px;"> ▲ to select SELF turns Self-Tune® function "on". ▼ to select PID turns manual PID tune "on". </div>	If SELF (Self-Tune® feature) is desired, press "Enter" and "Index" to condition PD6. If PID manual adjustment is desired, press "Enter". Condition PD2, PD3 or PD4, and PD5 can now be indexed to and changed directly without having to "Enter" PID tune again. This function may also be changed in "level 1 security".

















Programming For Self-Tune® or P.I.D. Control (Cont.)

CON- DITION	Display Reads	Change Value in Upper Display by Pressing	Comments
PD2.	<div style="border: 1px solid black; display: inline-block; padding: 2px;">#</div> <div style="border: 1px solid black; display: inline-block; padding: 2px;">Pb</div> to <div style="border: 1px solid black; display: inline-block; padding: 2px;">####</div> Set proportional band (in degrees or counts).	<div style="border: 1px solid black; display: inline-block; padding: 2px;">▲</div> or <div style="border: 1px solid black; display: inline-block; padding: 2px;">▼AL</div> Variable Speed	Proportional band can be selected from 6 (2 on 0.1° ranges) to 1000 Deg. F (or equivalent Deg. C) for temperature inputs or 6 to 4000 counts for current or voltage inputs. Press "Enter" to retain. Press "Index" to proceed to next programmable function (PD3).
PD3.	<div style="border: 1px solid black; display: inline-block; padding: 2px;">OFF</div> <div style="border: 1px solid black; display: inline-block; padding: 2px;">RES</div> to <div style="border: 1px solid black; display: inline-block; padding: 2px;">999</div> Automatic Reset. Set reset time (minutes).	<div style="border: 1px solid black; display: inline-block; padding: 2px;">▲</div> or <div style="border: 1px solid black; display: inline-block; padding: 2px;">▼AL</div> Variable Speed	Automatic Reset can be selected from 0.1 to 99.9 minutes in 6 second increments. If Automatic Reset is desired, press "Enter" and proceed to condition PD5. If <div style="border: 1px solid black; display: inline-block; padding: 2px;">OFF</div> is "Entered", then Automatic Reset is turned "Off". Condition PD4 will be displayed.
PD4.	<div style="border: 1px solid black; display: inline-block; padding: 2px;">OFF</div> <div style="border: 1px solid black; display: inline-block; padding: 2px;">OFS</div> to <div style="border: 1px solid black; display: inline-block; padding: 2px;">999</div> Manual Offset Correct	<div style="border: 1px solid black; display: inline-block; padding: 2px;">▲</div> or <div style="border: 1px solid black; display: inline-block; padding: 2px;">▼AL</div> Variable Speed	Manual Offset can be selected from 0.1 to 99.9% output at the set point. To correct offset, start at 50%. If the Process Value (PV) settles out below the set point increase the Manual Offset value above 50% and wait each time. Repeat until the PV settles out at the set point. If the PV settles out above the set point decrease the Manual Offset value below 50% and repeat if necessary. If <div style="border: 1px solid black; display: inline-block; padding: 2px;">OFF</div> is "Entered" then proceed back to condition PD3 (Automatic Reset).

Programming For Self-Tune® or P.I.D. Control (Cont.)

CON- DITION	Display Reads	Change Value in Upper Display by Pressing	Comments
PD5.	<p><input type="checkbox"/> OFF <input type="checkbox"/> RATE</p> <p>to</p> <p><input type="checkbox"/> 9999</p> <p>Automatic Rate. Set Rate time (minutes)</p>	<p><input type="checkbox"/> ▲ or <input type="checkbox"/> ▼</p> <p>Variable Speed</p>	<p>Automatic Rate can be selected from 0.01 to 99.99 minutes in 0.6 second increments. If <input type="checkbox"/> OFF is selected, Rate is turned "Off". Press "Enter" and proceed to condition D1.</p>
PD6.	<p><input type="checkbox"/> Start <input type="checkbox"/> Learn</p> <p>or</p> <p><input type="checkbox"/> Cont</p> <p>Re-start Self-Tune function when changing control process and indicates when initial PID values have been calculated.</p>	<p>Set-up mode only: <input type="checkbox"/> ▲ to select <input type="checkbox"/> Start</p>	<p>In Set-up Mode: When this menu item is selected, <input type="checkbox"/> Cont will automatically appear in the upper display if the Self-Tune function has learned the process and has set the proper PID parameters. If not, <input type="checkbox"/> Start will appear. Once a process has been learned (maybe during bench testing) and the control instrument is subsequently moved to a new process, always select <input type="checkbox"/> Start to avoid a long delay in learning the new process. This selection removes the old PID parameters from memory and the Self-Tune is free to immediately learn the new ones for the new process. Press "Enter" to retain.</p> <p>In Level 1 or 2 Mode: Displays <input type="checkbox"/> Start <input type="checkbox"/> Learn until initial values have been calculated, then displays <input type="checkbox"/> Cont <input type="checkbox"/> Learn as it continues to tune the process. This function can only be changed in Set-up as above.</p>
PD7.	<p><input type="checkbox"/> OFF <input type="checkbox"/> DFAC</p> <p>to</p> <p><input type="checkbox"/> ?</p> <p>Damping Factor. For selecting the ratio of Rate to Reset in the Self-Tune mode.</p>	<p>Set-up mode only: <input type="checkbox"/> ▲ or <input type="checkbox"/> ▼</p> <p>Single step OFF thru 7.</p>	<p>Use <input type="checkbox"/> OFF for PI control only (no Rate term). Factory set at 3. For fast response (underdamped) decrease this number. For slow response (overdamped) increase this number. Press "Enter" to retain. Press "Index" to proceed to the next function. Condition PD7 is not equipped in some controls.</p>

Control Output Functions

CON- DITION	Display Reads	Change Value in Upper Display by Pressing	Comments
D1.	<p> </p> <p>to Set Point #1</p> <p> cycle time in seconds</p> <p>For relay, 24 V.D.C. and triac output modules only</p>	<p> or </p> <p>Single step by 2</p>	<p>If time proportioning is not desired, depress "Decrement" key one step below 2 on the upper display. The next programmable function (D2) will be displayed. If this output is desired, press "Enter" to retain and proceed to condition E.</p>
D2.	<p> </p> <p>Fast triac for triac and 24 V.D.C. output modules only.</p> <p>or</p> <p> </p> <p>for current proportional output modules only.</p> <p>or</p> <p> </p> <p>for voltage proportional output modules only.</p>	<p> or </p> <p>Single step.</p>	<p>If these output functions are not desired, depress "Decrement" key one step below  on the upper display. The next programmable function (D3) will be displayed. If one of these outputs is desired, press "Enter" to retain the one selected and proceed to condition E.</p>
D3.	<p> </p> <p>Pulse proportioning for water or oil cooling applications only. For relay, triac and 24 V.D.C. output modules only.</p>	<p>—</p>	<p>If this output function is not desired, depress the "Decrement" key one step below  on the upper display. The next programmable function (D5) will be displayed. If this output is desired, depress the "Enter" key, D4 will be displayed.</p>

Control Output Functions (Cont.)

CON- DITION	Display Reads	Change Value in Upper Display by Pressing	Comments
D4.	<p> To Pulse rate for pulse output. Arbitrary setting. Set for best control results.</p>	<p> or Single step 1 thru 7.</p>	<p>For "Oil" cooling, use 1 thru 4. For "Water" cooling, use 3 thru 7. Press "Enter" to retain and proceed to condition E.</p>
D5.	<p> On/Off control for relay, triac and 24 V.D.C. output modules only.</p>	<p style="text-align: center;">—</p>	<p>If on-off control is not desired, depress "Index" key and proceed to condition E. If on/off control is desired, depress the "Enter" key, D6 will be displayed.</p>
D6.	<p> On/Off Differential for Set Point #1 if set for D5 condition. 2 degrees to full scale in one degree increments, or 0.5 to 999.0 degrees in 0.1 degree increments, limited by condition G.</p>	<p> or variable speed.</p>	<p>Number of degrees displayed remain the same regardless of F or C selection. Press "Enter" to retain and proceed to condition E. See Figure D6 for modes of operation.</p>

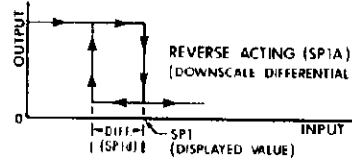
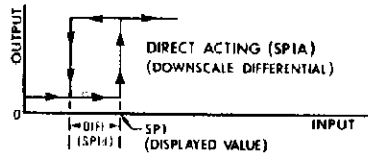

























FIG. D6 Modes of Operation

Note: For upscale differential — $SP1$ (displayed value) = Desired set point + differential (SP1d).

Other Control Functions

CON- DITION	Display Reads	Change Value in Upper Display by Pressing	Comments
E.	  or  temperature scale selection.	 Selects °F.  Selects °C.	All temperature values converted and displayed in chosen scale (except  differential and certain options). Press "Enter" to retain and proceed to condition F. Descriptor  or  to the right of the upper display will light. This condition not present on current or voltage inputs. See condition T8.
G.	  Lowest set point desired for Set Point #1, Alarm #1, Alarm #2 or on/off differential.	 or  variable speed.	This function sets the low end of the desired set point span of the control.
H.	  Highest set point desired for Set Point #1, Alarm #1, Alarm #2 or on/off differential.	 or  variable speed	This function sets the high end of the desired set point span of the control.
I.	  to  Low end output restriction	 or  variable speed	Usually used to select Current or Voltage output ranges desired when Current or Voltage output modules are used. Also used for time proportioning output with relay, 24 V.D.C. or triac driver output modules to restrict duty cycle so that the lowest power output may be increased for under powered heating systems. Adjustable from 0 to 90% of output or  value, whichever is lowest. See "  and  Selection".

Other Control Functions (Cont.)

CON- DITION	Display Reads	Change Value in Upper Display by Pressing	Comments
J.	<p> <input type="text" value="102"/> <input type="text" value="5.10%"/> to <input type="text" value="10"/> in percent High end output restriction </p>	<p> <input type="button" value="▲"/> or <input type="button" value="▼AL"/> variable speed </p>	<p>Same as <input type="text" value="5.10%"/> except adjusts high end of output. Also restricts duty cycle so that the highest power output may be decreased for over powered heating systems. Adjustable from 102 to 10% of output or <input type="text" value="5.10%"/> value, whichever is highest. See "<input type="text" value="5.10%"/> and <input type="text" value="5.10%"/> Selection".</p>
K.	<p> <input type="text" value="dir"/> <input type="text" value="SP 1R"/> or <input type="text" value="rE"/> Set Point #1 action-direct or reverse </p>	<p> <input type="button" value="▲"/> to select <input type="text" value="dir"/> <input type="button" value="▼AL"/> to select <input type="text" value="rE"/> </p>	<p>Direct acting: Relay, 24 V.D.C. or triac output energized above the set point. Current or Voltage output highest above the set point. Reverse acting is normally used for "heating" and direct acting for cooling. When controller reverts to "safe" conditions due to certain diagnostic information, all outputs turn off. See explanation under "Diagnostic Error Messages".</p>
L.	<p> <input type="text" value="on"/> <input type="text" value="SP 1L"/> or <input type="text" value="off"/> Set Point #1 status light "lit". </p>	<p> <input type="button" value="▲"/> lit when S.P. #1 output is "on". <input type="button" value="▼AL"/> lit when S.P. #1 output is "off". </p>	<p>If your controller is not equipped with alarms, proceed to Condition T.</p>

Alarm Functions (If Equipped)

















CAUTION: In any critical application where failure could cause expensive product loss or endanger personal safety, a second redundant limit controller is recommended.

	Display Reads	Change Value in Upper Display by Pressing	Comments
M.	<p>ABS REL or DE Alarm Type: Absolute or deviation</p>	<p>▲ to select ABS ▼_{AL} to select DE Affects both alarms</p>	<p>If absolute is selected, alarms stay at whatever set value is entered and do not follow the control set point if it is changed (non-tracking). If deviation is selected, the alarms, once set, will hold the same relationship to the control set point and will follow if the control set point is changed (tracking).</p>
N.	<p>DIR RI or RE Alarm #1 action direct or reverse</p>	<p>▲ to select DIR Direct Acting ▼_{AL} to select RE Reverse Acting</p>	<p>Direct acting: relay coil energized when the process value is <i>above</i> the alarm set point. Usually used for high alarm. Reverse acting: relay coil energized when the process value is <i>below</i> the alarm set point. Usually used for low alarm.</p>
O1.	<p>ON RL or OFF Alarm #1 status light "lit"</p>	<p>▲ lit when alarm #1 output is "ON". ▼_{AL} lit when alarm #1 output is "OFF".</p>	
O2.	<p>ON RL or OFF Alarm #1 status light flasher.</p>	<p>▲ to select ON ▼_{AL} to select OFF</p>	<p>When "ON" is selected, the alarm status light will flash when it is lit. When "OFF" is selected, the alarm status light will stay on steadily when lit.</p>
P1.	<p>ON RL or RL Alarm #1 reset choice. Automatic or manual</p>	<p>▲ to select ON automatic reset. ▼_{AL} to select RL manual reset</p>	<p>If automatic reset is selected, press "Enter" to retain and "Index" to condition Q. If manual reset is selected, press "Enter" to condition P2. With manual reset, once the alarm has been initiated, the condition must return to normal and the INDEX_{AL} and ▼_{AL} keys must be depressed at the same time to reset.</p>









Alarm Functions (If Equipped) (Cont.)

CON- DITION	Display Reads	Change Value in Upper Display by Pressing	Comments
P2.	<input type="checkbox"/> On <input type="checkbox"/> RL1P or <input type="checkbox"/> OFF Alarm #1 power interrupt function	<input type="button" value="▲"/> to select <input type="checkbox"/> On turns function "ON". <input type="button" value="▼"/> to select <input type="checkbox"/> OFF turns function "OFF".	Used only with manual alarm reset. If "ON" is selected, will automatically reset an alarm after a power failure and subsequent restoration if no alarm condition exists. Press "Enter" and proceed to condition Q.
Q.	<input type="checkbox"/> dir <input type="checkbox"/> RL2R or <input type="checkbox"/> RE Alarm #2 action direct or reverse	<input type="button" value="▲"/> to select <input type="checkbox"/> dir Direct Acting <input type="button" value="▼"/> to select <input type="checkbox"/> RE Reverse Acting	Direct Acting: relay coil energized when the process value is <i>above</i> the alarm set point. Usually used for high alarm. Reverse Acting: relay coil energized when the process value is <i>below</i> the alarm set point. Usually used for low alarm.
R1.	<input type="checkbox"/> On <input type="checkbox"/> RL2L or <input type="checkbox"/> OFF Alarm #2 status light "lit"	<input type="button" value="▲"/> lit when alarm #2 output is "ON". <input type="button" value="▼"/> lit when alarm #2 output is "OFF"	
R2.	<input type="checkbox"/> On <input type="checkbox"/> RL2F or <input type="checkbox"/> OFF Alarm#2 status light flasher	<input type="button" value="▲"/> to select <input type="checkbox"/> On <input type="button" value="▼"/> to select <input type="checkbox"/> OFF	When "ON" is selected, the alarm status light will flash when lit. When "OFF" is selected, the alarm status light will stay on steadily when lit.



























Alarm Functions (If Equipped) (Cont.)

CON- DITION	Display Reads	Change Value in Upper Display by Pressing	Comments
S1.	  or  Alarm #2 reset choice automatic or manual	 to select  automatic reset.  to select  manual reset	If automatic reset is selected, press "Enter" to retain and "Index" to condition T. If manual reset is selected, press "Enter" to condition S2. With manual reset, once the alarm has been initiated, the condition must return to normal and the  and  keys must be depressed at the same time to reset.
S2.	  or  Alarm #2 power interrupt function	 to select  Turns function "ON".  to select  Turns function "OFF".	Used only with manual alarm reset. If "ON" is selected, will automatically reset an alarm after a power failure and subsequent restoration if no alarm condition exists. Press "Enter" and proceed to Condition T.

Input Selection (Thermocouple and RTD only)

CON- DITION	Display Reads	Change Value in Upper Display by Pressing	Comments
T1.	Thermocouple E, J or K   or  or  or 	 or  Single Step	Do not "Enter"  . For factory use only. See "Input Wiring" for input type identification. Proceed to Condition U.

Input Selection (Thermocouple and RTD Only) (Cont.)

































CON- DITION	Display Reads	Change Value in Upper Display by Pressing	Comments
T2.	Thermocouple T, R or S    or  or  or 	 or  Single Step	Do not "Enter"  . For factory use only. See "Input Wiring" for input type identification. Proceed to Condition U.
T2A.	Thermocouple B, C or N    or  or  or 	 or  Single Step	Do not "Enter"  . For factory use only. See "Input Wiring" for input type identification. Proceed to Condition U. Factory programmed for type B. For type C or N a jumper must also be moved. See "Changing Sensors".
T3.	RTD CAL. 104, 105, or 106    or  or  or 	 or  Single Step	Do not "Enter"  . For factory use only. See "Input Wiring" for input type identification. Programming is complete. "Index" to "home" position or wait 8-10 seconds and "home" position will come automatically.

Input Selection (Thermocouple and RTD Only) (Cont.)

CON- DITION	Display Reads	Change Value in Upper Display by Pressing	Comments
U.	<div style="display: flex; justify-content: space-around;"> <input type="checkbox"/> On <input type="checkbox"/> ESC </div> <p style="text-align: center;">or</p> <div style="display: flex; justify-content: space-around;"> <input type="checkbox"/> OFF </div> <p>Thermocouple short protection</p>	<p style="text-align: center;"><input type="checkbox"/> ▲ to select <input type="checkbox"/> On</p> <p>Instrument constantly checks for a shorted thermocouple or an inoperative heater.</p> <p style="text-align: center;"><input type="checkbox"/> ▼AL to select <input type="checkbox"/> OFF</p> <p style="text-align: center;">Turns this function "OFF".</p>	<p>Before turning this function "ON", see "Set-up for T/C Short Protection". This completes programming. "Index" to "home" position or wait 8-10 seconds and "home" position will come automatically.</p>
V.	<p>— <input type="text" value="####"/> <input type="checkbox"/> InPC</p> <p style="text-align: center;">to</p> <p><input type="text" value="####"/></p> <p>Input Correction</p>	<p style="text-align: center;"><input type="checkbox"/> ▲ or <input type="checkbox"/> ▼AL</p> <p style="text-align: center;">Variable Speed</p>	<p>See "Set-up for Input Correction". The value of the Input Correction may be changed from -500 to $+500^{\circ}\text{F}$ or -278 to $+278^{\circ}\text{C}$ for temperature ranges with 1° resolution. For ranges with 0.1° resolution it may be changed from -500.0 to $+500.0^{\circ}\text{F}$ or -277.8 to $+277.8^{\circ}\text{C}$. Condition V is not equipped in some controls.</p>

After programming, turn the power to the instrument off, then on, and verify each programmed value or function. After verification, the program may be secured in either "level 1" or "level 2" security. See "The Security Switch".

Input Selection
(Current & Voltage Ranges Only) Viewable & changeable in "Setup" Mode only

CON- DITION	Display Reads	Change Value in Upper Display by Pressing	Comments
T4.	 Display low value	 or  Variable Speed	This function sets the low end of the scale range. Any  from 100 to 4000 counts below 
T5.	 Display high value	 or  Variable Speed	This function sets the high end of the scale range. Any  from 100 to 4000 counts above 
T6.	 or  or Decimal point position  or  ← No decimal pt. or 	 or  Single step.	This function sets the decimal point for 1, 2 or 3 numbers beyond the decimal point. Do not "Enter"  . For factory use only.
T7.	 or  Zero Suppression	 to select  turns function "ON".  to select  turns function "OFF".	Low end of scale range starts 20% above low end of input range. i.e., 0 to 20 MA input range becomes 4 to 20 MA input for scale.
T8.	 or  or  Engineering units descriptor	 or  Single step.	Select Engineering Units Descriptors:  = No descriptors. Apply appropriate label from multiple Engineering Units Label Card supplied with instrument in upper R.H. corner of silver area opposite "Set Point/Index" on the front of the instrument.  = °F descriptor.  = °C descriptor.

Input Selection
(Current & Voltage Ranges Only) Viewable & changeable in "Setup" Mode only

CON- DITION	Display Reads	Change Value in Upper Display by Pressing	Comments
T9.	<p><input type="checkbox"/> OFF <input type="checkbox"/> inPt to <input type="checkbox"/> 0.1 to <input type="checkbox"/> 5400 Input fault time</p>	<p><input type="checkbox"/> ▲ or <input type="checkbox"/> ▼AL Variable Speed</p>	<p>Outputs remain active for this time after <input type="checkbox"/> UFL or <input type="checkbox"/> OFL begins flashing. 0.1 min. (6 sec.) to 540.0 min. (9 hrs.) can be selected in 6 sec. increments. After this time outputs turn off (safe) and <input type="checkbox"/> bPd <input type="checkbox"/> inP is displayed. When <input type="checkbox"/> OFF has been selected the outputs remain active when <input type="checkbox"/> UFL or <input type="checkbox"/> OFL is flashing.</p>
T10.	<p>- <input type="checkbox"/> #### <input type="checkbox"/> inPC to <input type="checkbox"/> #### Input Correction</p>	<p><input type="checkbox"/> ▲ or <input type="checkbox"/> ▼AL Variable Speed</p>	<p>See "Set-up for Input Correction". The value of the input correction may be changed from -1000 to +1000 counts on current or voltage ranges. Condition T10 is not equipped in some controls.</p>

After programming, turn the power to the instrument off, then on, and verify each programmed value or function. After verification, the program may be secured in either "level 1" or "level 2" security. See "The Security Switch".

Set-up for T/C Short Protection

1. Leave **TC5** **OFF** under the following conditions:
 - a. Control set value is not greater than 190°F.
 - b. If the control application is "cooling".
 - c. Where there is more than one controller on a machine and adjacent zones will keep the heat from dropping even through one zone fails to heat.
 - d. If **bad** **inp** appears and **TC5** is **On** , then, control power is turned off, then on, and the process returns to the control set point.
 - e. While performing calibration or testing.
 - f. When using "ON-OFF" control.
2. Other considerations with **TC5** **On**
 - a. If T/C short or heater malfunction is intermittent, **bad** **inp** may not appear until the controller can no longer do its best to keep the process under control.
 - b. If power to the controller is turned off and then turned on again and the process value is less than 10° below the set value, **bad** **inp** may appear. Wait until the process value is greater than 10° below the set value or program **TC5** **OFF** .
 - c. If controller is moved from one process to another process **TC5** must be set up again.
3. To Set Up **TC5** , proceed as follows:
 - a. Security switch #1 must be in the up (on) position for "Set-up".
 - b. Actuate the "Index" key pad repeatedly until **Errn** appears on the lower display. Depress the **▲** key pad so that **Sett** appears on the upper display. Press the "Enter" key pad to retain.
 - c. Turn power to the controller off, then on, and verify each programmed value or function.
 - d. Return to either "level 1" or "level 2" security. See "The Security Switch."

Set-up for Input Correction

This feature allows the input value to be changed to agree with an external reference or to compensate for sensor error.

For example:

Assume that the controller Process Value (PV) reads 200° and an external reference instrument monitoring the same temperature reads 210°. In the "Set-up" mode Index to **inp** (usually last menu item). Change the value in the upper display by pressing the **▲** or **▼AL** keys until the value reads +10. Press "Enter". Return the control to the Level 1 or Level 2 security mode. Now, when the controller PV reads 200° the reference should also read 200°.

S10L and S10H Selection

Mode Selected In Condition D1 or D2	Output Range Desired	Set S10L Condition I to	Set S10H Condition J to	For other Output Values
<input type="checkbox"/> CP Current Proportional (Non-Isolated or Isolated)	0 TO 5 mA.	<input type="text" value="0"/>	<input type="text" value="25"/>	Multiply current (in mA.) desired by 5. S10H can be incremented to 102 (max.) = 20.4 mA.
	1 TO 5 mA.	<input type="text" value="5"/>	<input type="text" value="25"/>	
	2 TO 12 mA.	<input type="text" value="10"/>	<input type="text" value="60"/>	
	0 TO 20 mA.	<input type="text" value="0"/>	<input type="text" value="100"/>	
	4 TO 20 mA.	<input type="text" value="20"/>	<input type="text" value="100"/>	
<input type="checkbox"/> EP Voltage proportional (Non-Isolated)	0 TO 1 V.D.C.	<input type="text" value="0"/>	<input type="text" value="10"/>	Multiply voltage (in V.) desired by 10. S10H can be incremented to 102 (max.) = 10.2 V.
	0 TO 2 V.D.C.	<input type="text" value="0"/>	<input type="text" value="20"/>	
	0 TO 5 V.D.C.	<input type="text" value="0"/>	<input type="text" value="50"/>	
	1 TO 5 V.D.C.	<input type="text" value="10"/>	<input type="text" value="50"/>	
	4 TO 7 V.D.C.	<input type="text" value="40"/>	<input type="text" value="70"/>	
	0 TO 10 V.D.C.	<input type="text" value="0"/>	<input type="text" value="100"/>	
<input type="checkbox"/> EP Voltage proportional (Isolated)	0 TO 1 V.D.C.	<input type="text" value="0"/>	<input type="text" value="20"/>	Multiply voltage (in V.) desired by 20. S10H can be incremented to 102 (max.) = 5.1 V.
	0 TO 5 V.D.C.	<input type="text" value="0"/>	<input type="text" value="100"/>	
	1 TO 5 V.D.C.	<input type="text" value="20"/>	<input type="text" value="100"/>	
<input type="checkbox"/> CY1 * Time proportioning, fast triac or pulse	0 TO 100% DUTY CYCLE	<input type="text" value="0"/>	<input type="text" value="100"/>	Multiply duty cycle by 1. Increment to 100, 101, or 102 is still 100%.
	10 TO 90% DUTY CYCLE	<input type="text" value="10"/>	<input type="text" value="90"/>	

*Varying cycle rate will usually produce better control than varying S10L or S10H

Changing Sensors

Your controller is calibrated for three sensor types. See "Model Identification" for your input. To change from one type to another is done in programming. See Condition T1, T2, T2A or T3 under "Programming in the Set-up Mode" and follow instructions for programming to your desired sensor.

If the instrument is a B, C, N input type there is a jumper that must also be in the proper position as well is proper programming as in condition T2A. The jumper is located on the right side of the chassis along with an instruction label as in the following drawing.

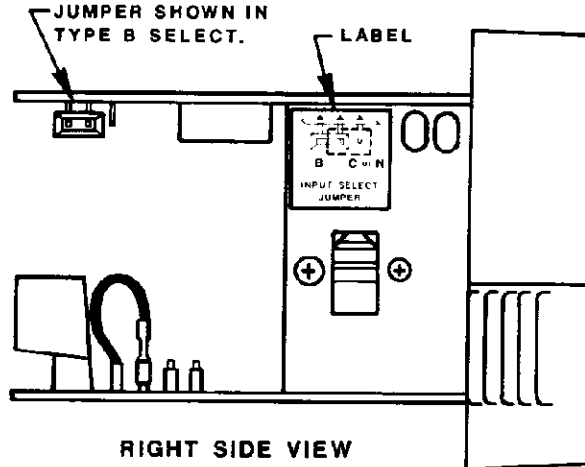

The jumper positions are also marked on the PC board as "EJK" and "TRS". The jumper must be in the "EJK" position for type B input or input or in the "TRS" position for types C or N input.

Changing Output Modules

Remove the controller from its housing as described under "Removal From the Housing". Locate the plug-in module and remove it by un-plugging both the small cable (if present) and the module from its socket.

Install new module and cable (if present).

Re-wire rear terminals of control for the external wiring proper for the newly installed module.

Place the internal security switch into the "Set-Up" condition as described under "The Security Switch".

Re-install the control into its housing and re-program "Control Output Functions" as outlined under "Programming in the Set-up Mode".

DIMENSIONS

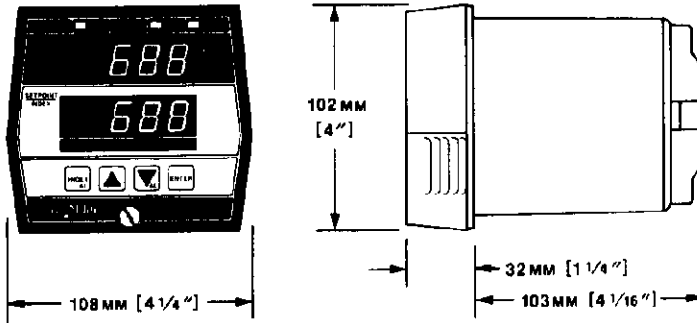

CUTOUT FOR ALL MODELS
92mm x 92mm (3⁵/₈" x 3⁵/₈")

LIMITED WARRANTY

Love Controls Corporation warrants to the Buyer that any equipment sold will be free from defects in materials or workmanship. If, at any time within sixty (60) months after shipment of Self-Tune® Plus Controls or within three (3) months after shipment of thermocouples or other assemblies or parts, the Seller is notified of such defect and the defective item is returned to Seller by Buyer, transportation prepaid, for examination, the Seller will, at his option, either repair or replace the defective items.

This warranty shall be effective only if installation and maintenance is in accordance with Sellers instructions and the defect is not caused by shipping damage, misuse or abuse by Buyer. There are no other warranties, written, oral or implied. The liability of the Seller shall be limited to the repair or replacement of the defective item as above set forth.

Items which wear or which are perishable by misuse are not warranted. These include, but are not limited to, relays, contact points, lamps, LED's, load SCR's, SSR's and triacs.

FACTORY DEFAULT FEATURE for MODEL 300 SERIES SINGLE OUTPUT CONTROLLERS

At times it may be necessary to reprogram the Controller back to the Factory Default Settings. The following procedure allows the operator to perform this with minimal effort.

To reset to Factory Default Values: (See the following tables)

1. Put the controller in the Set-up Mode (Switch 1 UP).
2. "INDEX" through the Menu until **inP** or **dP** appears in the Lower Display.
3. Press **▲** or **▼** until the Upper Display shows **----**, then press "ENTER" **FRCL** will appear in the Lower Display.
4. Press **▼** until **FRCL** **dFLt** appears in the Displays. Press "ENTER" first and hold, then press **▼**. The Display will blank and perform the Power Up sequence to the Home Position.
5. Perform the programming for the Set-up Menu as required for the Process to be Controlled.

NOTE: Should the Controller display **FRIL** **EESt**, pressing the "INDEX" will cause one of the following messages to appear.

- FRCL** = Memory has been corrupted. Refer to steps 4 & 5 above.
- dFLt** In some cases the Controller may require Calibration. Contact the Factory for the proper Instructions.
- bRd** = All of the Security Switches are Open. Check the Switch and if it appears OK, move it OFF and ON. If this does not correct the problem, return to the Factory.
- SSEr**
- bRd** = The A/D board is Bad. Replace the A/D board or return to the Factory for service.
- R-d**
- rEt** = Not Recoverable, return to the Factory for service.
- FRCL**

FACTORY DEFAULT VALUES FOR SINGLE OUTPUT CONTROLLERS

CON- DITION	LOWER DISPLAY	THERMOCOUPLE INPUTS			RTD INPUTS		CURRENT or VOLTAGE
		EJK	TRS	BCN	1°	0.1°	
A.	SP1	175 °F			175 °F	175.0 °F	175
B.	AL1	150°			150 °F	150 °F	150
C.	AL2	200 °F			200 °F	200.0 °F	200
PD1.	LnE	SELF					
PD6.	LERn	Strt					
PD7.	dFAC	3					
D1.	CY1	10					
E.	F-C	F					N.A.
G.	SPL	-100 °F	0 °F	*75 °F	-328 °F	-200.0°F	0
H.	SPH	1600 °F	3200 °F	3308 °F	1607 °F	990.0 °F	400
I.	S10L	0					
J.	S10H	100					
K.	SP1A	rE					
L.	SP1L	0 on					
M.	ALt	AbS					
N.	AL1A	rE					
O1.	AL1L	0 on					
O2.	AL1F	On					
P1.	AL1r	OnOF					
Q.	AL2A	dir					
R1.	AL2L	0 on					
R2.	AL2F	On					
S1.	AL2r	OnOF					
T1,2,2A,3.	InP	J-IC	S-10	b	106		N.A.
T4.	SCAL	N.A.					0
T5.	SCAH	N.A.					400
T6.	dP	N.A.					none
T7.	OSUP	N.A.					OFF
T8.	Unit	N.A.					0
T9.	InPt	N.A.					OFF
U.	tCS	OFF	OFF	OFF	N.A.		
V.	InPC	0					

N.A. = Not Applicable

FACTORY DEFAULT VALUES FOR MODEL 300 OPTIONS

OPTION No. and DESCRIPTION	LOWER DISPLAY	THERMOCOUPLES EJK, TRS, BCN	RTD		CURRENT VOLTAGE
			1°	0.1°	
-524 LOCAL/REMOTE SET Pt	LorE		LOC		
-526	rSCL		0		
-528	rSCH		200		
	rSUP		1		
-529 KEYBOARD AUTO/MAN	N.A.		Defaults to AUTO		
-530 MENU AUTO/MAN	Auto		On		
-531 BAD INPUT AUTO/MAN	Out		IPrE		
	IPrE		0		
-532 SWITCH AUTO/MAN	Out		SPrE		
	SPrE		0		
-534 PROCESS OUTPUT	POL		0		
-536	POH	200	50.0	200	
-540 PEAK & VALLEY	PEA		175		
	UAL		175		
-544 PERCENT OUTPUT	PctO		OFF		
-546 TRANSFER FROM MAN TO AUTO AT SET Pt.	trAn		OFF		
	Out		0.0		
-548 TWO STAGE SET Pt.	1SP1		175		
-549	2SP1		180		
-558 LEVEL 2 SECURITY	L2S		0		
-559 LEVEL 1 SECURITY	L1S		0		
-580 GUARD ALARM 2	AL1	-15	-1.5	15	
	AL2	10	1.0	10	
-590 RS-485 SERIAL	Addr		32		
-592 COMMUNICATIONS	bAUd		19.2		
	LOrE		LOC		
	CFSP		185		
	nAt		OFF		
	CFLT		1		
-5120 AUXILIARY ON/OFF SECOND SET Pt.	SP2		180		
-5121	SP2d		-10		
-5122	SP2A		dir		
-5123	SP2L		O on		

N.A. = Not Applicable

PROGRAM SELECTION TABLE

Use this table to fill in programming choices as an aid when programming your controller. Make copies of this blank table or request additional copies from the factory.

SET POINTS

Index Item	Choices	Choice
<div style="border: 1px solid black; display: inline-block; padding: 2px;">####</div> <div style="border: 1px solid black; display: inline-block; padding: 2px;">SP1</div> Set Point 1	Any value within <div style="border: 1px solid black; display: inline-block; padding: 2px;">SP_L</div> and <div style="border: 1px solid black; display: inline-block; padding: 2px;">SP_H</div>	
<div style="border: 1px solid black; display: inline-block; padding: 2px;">####</div> <div style="border: 1px solid black; display: inline-block; padding: 2px;">AL1</div> Alarm Point 1	Any value within <div style="border: 1px solid black; display: inline-block; padding: 2px;">SP_L</div> and <div style="border: 1px solid black; display: inline-block; padding: 2px;">SP_H</div> If alarms are present	
<div style="border: 1px solid black; display: inline-block; padding: 2px;">####</div> <div style="border: 1px solid black; display: inline-block; padding: 2px;">AL2</div> Alarm Point 2	Any value within <div style="border: 1px solid black; display: inline-block; padding: 2px;">SP_L</div> and <div style="border: 1px solid black; display: inline-block; padding: 2px;">SP_H</div> If alarms are present	

PROGRAMMING FOR SELF-TUNE® OR PID CONTROL

Index Item	Choices	Choice
<div style="border: 1px solid black; display: inline-block; padding: 2px;">SELF</div> <div style="border: 1px solid black; display: inline-block; padding: 2px;">tune</div> or <div style="border: 1px solid black; display: inline-block; padding: 2px;">P.d</div> Self-Tune® or manual tune PID	<div style="border: 1px solid black; display: inline-block; padding: 2px;">SELF</div> or <div style="border: 1px solid black; display: inline-block; padding: 2px;">P.d</div>	
<div style="border: 1px solid black; display: inline-block; padding: 2px;">#</div> <div style="border: 1px solid black; display: inline-block; padding: 2px;">Pb</div> Proportional Band (Heating)	6 to 1000 °F (or equivalent °C) for temp inputs or 6 to 4000 counts for current or voltage inputs.	
<div style="border: 1px solid black; display: inline-block; padding: 2px;">OFF</div> <div style="border: 1px solid black; display: inline-block; padding: 2px;">rES</div> to <div style="border: 1px solid black; display: inline-block; padding: 2px;">999</div> Automatic Reset time	Off=no reset or select from 0.1 to 99.9 minutes in 6 second increments.	
<div style="border: 1px solid black; display: inline-block; padding: 2px;">OFF</div> <div style="border: 1px solid black; display: inline-block; padding: 2px;">OFS</div> to <div style="border: 1px solid black; display: inline-block; padding: 2px;">999</div> Manual offset Correct	Select from 0.1 to 99.9%. OFF = Must select reset time.	
<div style="border: 1px solid black; display: inline-block; padding: 2px;">OFF</div> <div style="border: 1px solid black; display: inline-block; padding: 2px;">rEt</div> to <div style="border: 1px solid black; display: inline-block; padding: 2px;">9999</div> Automatic Rate time	Off=no rate or select from 0.01 to 99.99 minutes in 0.6 second increments.	
<div style="border: 1px solid black; display: inline-block; padding: 2px;">SELF</div> <div style="border: 1px solid black; display: inline-block; padding: 2px;">LErn</div> or <div style="border: 1px solid black; display: inline-block; padding: 2px;">Cont</div> Restart self-tune learn Continue self-tune learn	<div style="border: 1px solid black; display: inline-block; padding: 2px;">SELF</div> or <div style="border: 1px solid black; display: inline-block; padding: 2px;">Cont</div>	

CONTROL OUTPUT FUNCTIONS

Relay Output Module

Index Item	Choices	Choice
<input type="text" value="##"/> <input type="text" value="CY"/> Cycle rate (time proportioning)	<input type="text" value="2"/> to <input type="text" value="80"/> seconds.	
or <input type="text" value="PUL"/> <input type="text" value="OUT"/> * Pulse output (Pulse proportioning)	<input type="text" value="1"/> to <input type="text" value="1"/>	
or <input type="text" value="ONOFF"/> <input type="text" value="OUT"/> * on-off output	<input type="text" value="SPID"/> set point on-off differential <input type="text" value="2"/> degrees to <input type="text" value="SPH"/> or <input type="text" value="05"/> degrees to <input type="text" value="9990"/>	

*When confirming these functions after programming, press "Enter" to display the pulse output or on-off differential choice.

Triac Output Module and 24 V.D.C. Output Module

Index Item	Choices	Choice
<input type="text" value="##"/> <input type="text" value="CY"/> cycle rate (time proportioning)	<input type="text" value="2"/> to <input type="text" value="80"/> seconds	
or <input type="text" value="FT"/> <input type="text" value="OUT"/> fast triac output	no other adjustment necessary for this index item	
or <input type="text" value="PUL"/> <input type="text" value="OUT"/> * Pulse output (pulse proportioning)	<input type="text" value="1"/> to <input type="text" value="1"/>	
or <input type="text" value="ONOFF"/> <input type="text" value="OUT"/> * on-off output	<input type="text" value="SPID"/> set point on-off differential <input type="text" value="2"/> degrees to <input type="text" value="SPH"/> or <input type="text" value="05"/> degrees to <input type="text" value="9990"/>	

*When confirming these functions after programming, press "Enter" to display the pulse output or on-off differential choice.

Current Proportional Output Modules

Index Item	Choices	Choice
<input type="text" value="CP"/> <input type="text" value="OUT"/> Current proportional output	No other adjustment necessary for this index item	

Voltage Proportional Output Modules

Index Item	Choices	Choice
<input type="text" value="VP"/> <input type="text" value="OUT"/> Voltage proportional output	No other adjustment necessary for this index item	

OTHER CONTROL FUNCTIONS

Index Item	Choices	Choice
<input type="checkbox"/> F or <input type="checkbox"/> F-C <input type="checkbox"/> C Degrees fahrenheit or degrees celsius	<input type="checkbox"/> F or <input type="checkbox"/> C This condition not present on current or voltage inputs. See "Input Selection (Current and Voltage Ranges)."	
<input type="checkbox"/> #### <input type="checkbox"/> SP L Set Point low end	any <input type="checkbox"/> #### within range span	
<input type="checkbox"/> #### <input type="checkbox"/> SP H Set Point high end	any <input type="checkbox"/> #### within range span	
<input type="checkbox"/> ## <input type="checkbox"/> S 1 L Set Point 1 output low end restriction	<input type="checkbox"/> 0 to <input type="checkbox"/> 99 percent	
<input type="checkbox"/> ## <input type="checkbox"/> S 1 H Set Point 1 output high end restriction	<input type="checkbox"/> 10 to <input type="checkbox"/> 10 percent	
<input type="checkbox"/> dir or <input type="checkbox"/> SP 1 R <input type="checkbox"/> r E Set Point 1 action direct or reverse acting	<input type="checkbox"/> dir or <input type="checkbox"/> r E	
<input type="checkbox"/> on or <input type="checkbox"/> SP 1 L <input type="checkbox"/> off Set Point 1 status light lit with output on or with output off	<input type="checkbox"/> on or <input type="checkbox"/> off	

ALARM FUNCTIONS (IF PRESENT)

Index Item	Choices	Choice
<input type="checkbox"/> Abs or <input type="checkbox"/> Rel <input type="checkbox"/> dE Alarm type absolute (non-tracking) or deviation (tracking)	<input type="checkbox"/> Abs or <input type="checkbox"/> dE	
<input type="checkbox"/> dir or <input type="checkbox"/> RLIR <input type="checkbox"/> rE Alarm 1 action direct acting (high alarm) or reverse acting (low alarm)	<input type="checkbox"/> dir or <input type="checkbox"/> rE	
<input type="checkbox"/> On or <input type="checkbox"/> RLIL <input type="checkbox"/> OFF Alarm 1 status light lit with output on or with output off	<input type="checkbox"/> On or <input type="checkbox"/> OFF	
<input type="checkbox"/> On or <input type="checkbox"/> RLIF <input type="checkbox"/> OFF Alarm 1 status light flasher on or off	<input type="checkbox"/> On or <input type="checkbox"/> OFF	
<input type="checkbox"/> OnOFF or <input type="checkbox"/> RLIR <input type="checkbox"/> RL Alarm 1 reset type, on-off (automatic) or alarm (manual)	<input type="checkbox"/> OnOFF or <input type="checkbox"/> RL * IF <input type="checkbox"/> RL is selected, then also select <input type="checkbox"/> RLIP, alarm 1 power interrupt function <input type="checkbox"/> On or <input type="checkbox"/> OFF	
<input type="checkbox"/> dir or <input type="checkbox"/> RL2R <input type="checkbox"/> rE Alarm 2 action direct acting (high alarm) or reverse acting (low alarm)	<input type="checkbox"/> dir or <input type="checkbox"/> rE	
<input type="checkbox"/> On or <input type="checkbox"/> RL2L <input type="checkbox"/> OFF Alarm 2 status light lit with output on or with output off	<input type="checkbox"/> On or <input type="checkbox"/> OFF	
<input type="checkbox"/> On or <input type="checkbox"/> RL2F <input type="checkbox"/> OFF Alarm 2 status light flasher on or off	<input type="checkbox"/> On or <input type="checkbox"/> OFF	

ALARM FUNCTIONS (IF PRESENT) (Continued)

Index Item	Choices	Choice
<input type="checkbox"/> OnOff or <input type="checkbox"/> RL2r <input type="checkbox"/> RL Alarm 2 reset type, on-off (automatic) or alarm (manual)	<input type="checkbox"/> OnOff or <input type="checkbox"/> RL * if <input type="checkbox"/> RL is selected, then also select <input type="checkbox"/> RL2P, alarm 2 power interrupt function <input type="checkbox"/> On or <input type="checkbox"/> Off	

*When confirming these functions after programming, if RL has been selected, press "Enter" to display the alarm power interrupt function choice.

INPUT SELECTION (THERMOCOUPLE AND RTD ONLY)

Thermocouple Types E, J or K

Index Item	Choices	Choice
<input type="checkbox"/> E- or <input type="checkbox"/> J-12 <input type="checkbox"/> InP or <input type="checkbox"/> KR Thermocouple input	<input type="checkbox"/> E- = Type E, Chrome/Constantan <input type="checkbox"/> J-12 = Type J, Iron/Constantan <input type="checkbox"/> KR = Type K, Chrome/Alumel	
<input type="checkbox"/> On or <input type="checkbox"/> ELS <input type="checkbox"/> Off Thermocouple short protection	<input type="checkbox"/> On or <input type="checkbox"/> Off	
- <input type="checkbox"/> #### to <input type="checkbox"/> InP <input type="checkbox"/> #### Input Correction	Any <input type="checkbox"/> #### within the input correction range.	

Thermocouple Types T, R or S

Index Item	Choices	Choice
<input type="checkbox"/> E- or <input type="checkbox"/> r-13 <input type="checkbox"/> InP or <input type="checkbox"/> S-10 Thermocouple input	<input type="checkbox"/> E- = Type T, Copper/Constantan <input type="checkbox"/> r-13 = Type R, Plat, 13% RH./Plat. <input type="checkbox"/> S-10 = Type S, Plat, 10% RH./Plat.	
<input type="checkbox"/> On or <input type="checkbox"/> ELS <input type="checkbox"/> Off Thermocouple short protection	<input type="checkbox"/> On or <input type="checkbox"/> Off	
- <input type="checkbox"/> #### to <input type="checkbox"/> InP <input type="checkbox"/> #### Input Correction	Any <input type="checkbox"/> #### within the input correction range.	

Thermocouple Types B, C or N

Index Item	Choices	Choice
<input type="checkbox"/> b or <input type="checkbox"/> c <input type="checkbox"/> inP or <input type="checkbox"/> n Thermocouple input	<input type="checkbox"/> b = Type B, Plat, 6% RH./Plat. 30% RH. <input type="checkbox"/> c = Type C, W5% RE/W 26% RE <input type="checkbox"/> n = Type N, NiCro Sil/Ni Sil	
<input type="checkbox"/> On or <input type="checkbox"/> tCS <input type="checkbox"/> OFF Thermocouple short protection	<input type="checkbox"/> On or <input type="checkbox"/> OFF	
- <input type="checkbox"/> #### to <input type="checkbox"/> inPC <input type="checkbox"/> #### Input Correction	Any <input type="checkbox"/> #### within the input correction range.	

RTD Calibrations 104, 105 or 106

Index Item	Choices	Choice
<input type="checkbox"/> 104 or <input type="checkbox"/> 105 <input type="checkbox"/> inP or <input type="checkbox"/> 106 RTD input	<input type="checkbox"/> 104 = Platinum 100 OHMS at 0°C. (American curve) alpha = .00392 OHMS/OHM/°C. <input type="checkbox"/> 105 = nickel 120 OHMS at 0°C. <input type="checkbox"/> 106 = platinum 100 OHMS at 0°C. (DIN curve) alpha = .00385 OHMS/OHM/°C.	
- <input type="checkbox"/> #### to <input type="checkbox"/> inPC <input type="checkbox"/> #### Input Correction	Any <input type="checkbox"/> #### within the input correction range.	

Input Selection (Current and Voltage Ranges Only)

Index Item	Choices	Choice
<input type="checkbox"/> #### <input type="checkbox"/> SCRL Display low value.	Any <input type="checkbox"/> #### from 100 to 4000 counts below <input type="checkbox"/> SCRL	
<input type="checkbox"/> #### <input type="checkbox"/> SCRH Display high value	Any <input type="checkbox"/> #### from 100 to 4000 counts above <input type="checkbox"/> SCRL	
<input type="checkbox"/> . or <input type="checkbox"/> . or <input type="checkbox"/> dP <input type="checkbox"/> . or <input type="checkbox"/> Decimal point position	<input type="checkbox"/> . .1 resolution or <input type="checkbox"/> . .01 resolution or <input type="checkbox"/> . .001 resolution or <input type="checkbox"/> 1 unit resolution. No decimal point	

Input Selection (Current and Voltage Ranges Only) (continued)

Index Item	Choices	Choice
<input type="checkbox"/> On or <input type="checkbox"/> 20% SUP <input type="checkbox"/> OFF 20% zero suppression	<input type="checkbox"/> On or <input type="checkbox"/> OFF	
<input type="checkbox"/> : or <input type="checkbox"/> : <input type="checkbox"/> <input type="checkbox"/> or <input type="checkbox"/> : Engineering units descriptor	<input type="checkbox"/> no descriptor (apply label) or <input type="checkbox"/> °F descriptor or <input type="checkbox"/> °C descriptor	
<input type="checkbox"/> OFF to <input type="checkbox"/> 0.1 <input type="checkbox"/> inPt to <input type="checkbox"/> 5400 Input fault time	<input type="checkbox"/> OFF to <input type="checkbox"/> 5400 minutes in <input type="checkbox"/> 0.1 minute (6 second) increments	
<input type="checkbox"/> #### to <input type="checkbox"/> inPt <input type="checkbox"/> #### Input Correction	Any <input type="checkbox"/> #### within the input correction range.	