

## Technical Information

### Control Systems Selection Guidelines

#### Topics:

- Process controls, overtemperature controls, level controls, sensors, power controls, and panels.

Now that you have selected the heater(s) for your process, it is time to choose control components, panels, and sensors, to provide the desired results.

#### System Considerations

In order to assemble a complete control system, you will need the following information:

- **Voltage, wattage, current** (calculated from voltage and wattage),
- **Number of zones:** (different sections controlled differently),
- **Area location or classification:** (indoor, outdoor, explosion hazard), and
- **The desired process temperature range**, as well as permitted deviations should be specified. Close control and/or control of one pass heating of gas or liquids will probably require electronic control.
- **Process accuracy issues:** For large mass processes (big tanks, large blocks of metal) where the temperature won't or can't move quickly, and the temperature requirement is not critical, mechanical bulb and capillary thermostats can usually be used, or if electronic control with indication is needed a simple On/Off controller with a contactor is necessary.
- **Process speed:** For processes having low mass, fast, accurate control is important. A proportional or PID controller with an SCR power controller would be a good choice.
- **Process upset:** If the process is subject to upset, (oven door opened for new batch, for instance), a PID control will be required for good results. This is also the case if heating liquid or gas (air) in one pass. An SCR will be needed as well.
- **Environmental (ambient conditions):** Process controls, overtemperature controls, and accessories must be selected with the surrounding area in mind. Wet, dry, and explosion hazard areas must be considered, as well as the ambient temperature range the equipment will operate in. Mechanical controls should not be exposed to temperatures above their stated range. Electronic controls are designed to operate in an ambient temperature of above 32°F, and below a stated maximum, usually 120 or 140°F.
- **Safety:** An overtemperature control should be included to protect process, area, heater(s), and/or product in the event of a primary control failure, or interruption of flow in moving systems. If the power control is an SCR, a contactor or shunt trip should be provided so the load can be shut down, even if the SCR's are shorted. If heating confined liquid or gas, an approved mechanical temperature/pressure relief valve is also required. For some areas, ASME certification may be required on pressure vessels.

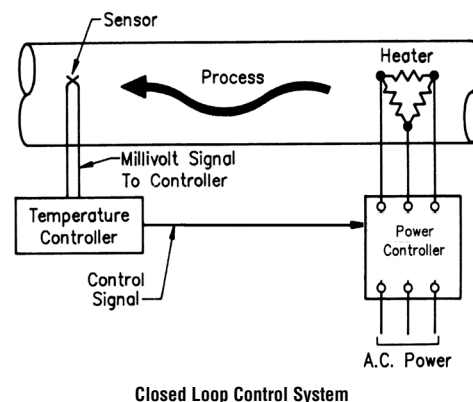

#### System Components

These parameters will help you determine the system components you need:

- **Sensor:** This can be a bulb and capillary, thermocouple, RTD or non-contact IR sensors.
- **Temperature Controller:** This can be a mechanical bulb & capillary controller or an electronic controller to accurately control the process.
- **Overtemperature Controller (Limits):** For protection of the process and/or the heater sheath, an overtemperature controller should always be used to ensure safe operation in the event of process control failure and/ or interruption of flow in dynamic systems.
- **Power Controller:** In order to switch the heater load, either mechanical contactors or SCR's are needed.

#### Sensors

The sensor is the device measuring the temperature or other variable of a system. It is usually in direct contact with the heated medium and must be specified to handle the temperature and conditions of the process. Electronic controllers convert the signal from RTD's and thermocouples to a temperature reading.

#### Thermocouples

Rugged and versatile, with many selections for various temperature ranges, thermocouples consist of two different material wires welded together. These devices produce a very small DC voltage, depending on temperature and thermocouple type. The controller or overtemperature controller, interprets this voltage, and compares it with internal standards, displaying and/or controlling a temperature.

Advantages: Lots of choices, rugged, inexpensive.

## Technical Information

### Control Systems Selection Guidelines (*cont'd.*)

Disadvantages: Output is not linear with temperature when new thermocouples are within 2 to 3°F accuracy. Thermocouple alloys age, which affects accuracy further.

Microprocessor controls are best at interpreting TC voltage curves. Thermocouple wire of the same type as the thermocouple (i.e. type J for J), must be used to connect the thermocouple to the controller. **Note:** The red lead is always the negative lead in USA thermocouple color-coding.

#### RTD'S

RTD's or Resistance Temperature Detectors, provide a resistance change linearly related to a temperature change. The most common is the 100-ohm platinum. The controller measures the change of resistance, and relates it to temperature.

Advantages: RTD's are much more accurate and more linear than thermocouples. Standard copper wire can be used to connect the sensor to the control. Since the signal is larger than a thermocouple signal, it is more immune to electrical noise. Three wire RTD's can also be run longer distances than thermocouples.

Disadvantages: RTD's are more costly than thermocouples, and less rugged. In addition, they should not be exposed to a temperature higher than their rated operating temperature. Don't weld or braze them.

#### Transmitters

A transmitter is an electronic circuit that converts the low level signal of a thermocouple, RTD, or other device or parameter (like humidity) to a current loop, typically a 4 to 20mA signal. This produces better immunity to noise than the low-level signal by itself.

Advantage: Longer control signal runs are possible without interference.

Disadvantage: Increased cost of installation.

#### Infrared Sensor

IR (non-contact) sensors provide a control signal related to the temperature of an object, without touching the object. The IR sensor "looks" at the process, and adds or reduces heat as required. They are often used in continuous processes where material is passing through a convection oven or under radiant heaters.

Advantages: Provides good closed loop control for flowing processes or surface drying applications.

Disadvantages: More expensive than contact sensors. Does not work well for shiny objects. A temperature control is still required to interpret the output of an IR sensor, compare it to the setpoint, and operate a power controller.

#### Sensor Placement

Placement is very important for a good control result. The temperature control, no matter how smart its PID loop is, can only process the information supplied to it.

Where possible, in a block type system (like a platen) the heater, sensor and load (die) should be as close together as possible. This minimizes thermal lag, and provides good response to changes. (See Figure 1)

In a stable system, where the heater is separated from the load, the sensor can be placed near the heater to provide for close heater control. The load will be cooler than the sensed temperature by the drop through the heat transfer path from the heater to the load. This is not good for changing condition systems. (See Figure 2)

A compromise may be provided for by placing the sensor between the heater and the load. This is good for fairly stable systems where the heat demand may be alternately constant or variable. (See Figure 3)

For changing systems, the sensor can be placed closer to the load to respond to changing load requirements. The sensor farther from the heater increases the thermal load. This will cause overshoots and undershoots. A PID controller is required to minimize the temperature cycling. (See Figure 4)

In conclusion, it is important that the heater, sensor and load be as close as possible. The sensor should always be between the heater and the load.

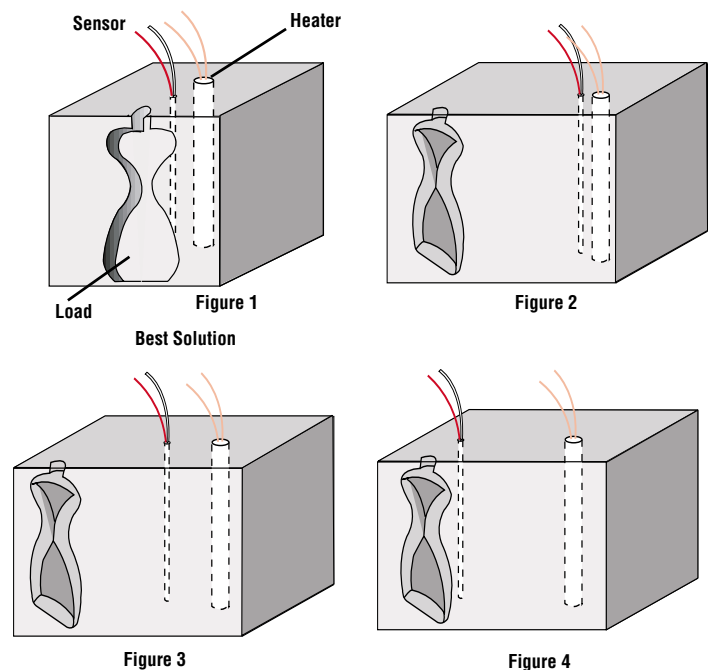

## Technical Information

### Control Systems Selection Guidelines (*cont'd.*)

#### Wiring

Thermocouple extension wire of the same type as the thermocouple (J for J) must be used to connect controls to sensors. Many varieties of thermocouple extension wire are available, with insulation types for different environments. For thermocouples, the negative(-) lead is always red in the USA. Copper wire can be used for RTD's and 4-20mA signals. RTD's and thermocouples have low level electrical signals. Shielding is recommended. The shield should only be grounded at one end (the controller end) to avoid ground loops. Sensor wires should not be run in the same conduit as power wires to prevent interference.

#### Environmental and Safety

Sensors and accessories must be selected with the surrounding area in mind. Wet, dry and explosion hazard areas must be considered, as well as the ambient temperature range the equipment will see. Insulation for extension wiring must also be able to withstand the ambient conditions. Electronic sensors and transmitters are designed to operate above 32°F, and below a stated maximum, usually 120 or 140°F. See specific unit for operating ambient temperature range.

#### Choosing a Sensor

##### Selection Criteria

The most popular sensor is the thermocouple, and of those, J and K are most frequently used. Select a TC with a temperature range matched to your process. For best accuracy, use an RTD unless your temperature range does not permit.

Service issues: When placing a sensor through the side of a tank of liquid, consider using a sensor with a thermowell, so the sensor can be replaced without draining the tank.

Thermocouple Type	Temp Range	Recommended Temperature Range	Temperature Range for Standard Limits of Error	Standard Limits of Error	Negative Wire Color	Positive Wire Color	Jack & Plug Color	Application Information
<b>J</b>	-300 to 1400°F	32 to 1400°F	32 to 527°F (0 to 275°C) 559 to 1400°F (293 to 760°C)	+/- 4°F +/- .75%	RED	WHITE	BLACK	Suitable for vacuum, reducing, or inert atmospheres, oxidizing atmosphere with reduced life. Iron oxidizes rapidly above 1000°F (538°C), so only heavy gauge wire is recommended for high to sulphurous atmospheres above 1000°F (538°C).
<b>K</b>	-450 to 2300°F	32 to 2300°F	-328 to -166°F (-200 to -110°C) -166 to 32°F (-110 to 0°C) 32 to 559°F (0 to 293°C) 559 to 2282°F (293 to 1250°C)	+/- 2% +/- 4°F +/- 4°F +/- .75%	RED	YELLOW	YELLOW	Recommended for continuous oxidizing or neutral atmospheres. Mostly used above 1000°F (538°C). Subject to failure if exposed to sulphur. Preferential oxidation of chromium in positive leg at certain low oxygen concentrations causes 'green rot' and large negative calibration drifts most serious in the 1500-1900°F (816-1038°C) range. Ventilation or inert-sealing of the protection tube can prevent this.
<b>T</b>	-450 to 700°F	-300 to 700°F	-328 to -89°F (-200 to -67°C) -89 to 32°F (-67 to 0°C) 32 to 271°F (0 to 133°C) 271 to 662°F (133 to 370°C)	+/- 1.5% +/- 1.8°F +/- 1.8°F +/- .75%	RED	BLUE	BLUE	Useable in oxidizing, reducing, or inert atmospheres as well as vacuum. Not subject to corrosion in moist atmospheres. Limits of error published for sub-zero temperature ranges.
<b>E</b>	-450 to 1800°F	32 to 1600°F	-328 to -274°F (-200 to -170°C) -274 to 32°F (-170 to 0°C) 32 to 644°F (0 to 340°C) 644 to 1652°F (340 to 900°C)	+/- 1% +/- 3.1°F +/- 3.1°F +/- 0.5%	RED	PURPLE	PURPLE	Recommended for continuously oxidizing or inert atmospheres. Sub-zero limits of error not established. Highest thermoelectric output of common calibrations.
<b>N</b>	32 to 4200°F	32 to 2300°F	32 to 559°F (0 to 293°C) 559 to 2300°F (293 to 1260°C) to °F ( to °C) to °F ( to °C)	+/- 4°F +/- .75%	RED	ORANGE	ORANGE	Can be used in applications where Type K elements have shorter life and stability problems due to oxidation and the development of 'green rot'.
<b>R</b>	32 to 2700°F	1000 to 2700°F	32 to 1112°F (0 to 600°C) 1112 to 2642°F (600 to 1450°C)	+/- 2.7°F +/- .25%	RED	BLACK	GREEN	Recommended for high temperature. Must be protected with non-metallic protection tube and ceramic insulators. Continued high temperature usages causes grain growth which can lead to mechanical failure. Negative calibration drift caused by Rhodium diffusion to pure leg as well as from Rhodium volatilization. Type R is used in industry; Type S in the laboratory.
<b>S</b>	32 to 2700°F	1000 to 2700°F	32 to 1112°F (0 to 600°C) 1112 to 2642°F (600 to 1450°C)	+/- 2.7°F +/- .25%	RED	BLACK	GREEN	Same as R & S but output is lower. Also less susceptible to grain growth and drift.
<b>B</b>	1472 to 3100°F	1600 to 3100°F	1472 to 3092°F (800 to 1700°C)	+/- 0.5%	RED	GRAY	WHITE	Same as R & S but output is lower. Also less susceptible to grain growth and drift.

## Technical Information

### Control Systems Selection Guidelines *(cont'd.)*

Recommended Upper Temperatures for Protected Thermocouples					
Thermocouple Type	Sheath Diameters & Wire Sizes for Single Elements				Maximum Element Temperature
	1/16 OD	1/8 OD	3/16 OD	1/4 OD	
	28 Gauge	22 Gauge	19 Gauge	16 Gauge	
<b>J</b>	700°F	700°F	900°F	900°F	1400°F
<b>K</b>	1600°F	1600°F	1800°F	1800°F	2300°F
<b>T</b>	400°F	400°F	500°F	500°F	700°F
<b>E</b>	800°F	800°F	1000°F	1000°F	1600°F
<b>N</b>	2300°F	2300°F	1800°F	1800°F	2300°F

### *Temperature or Process Controllers*

Electric heat, while clean, efficient and manageable, can cause damage to product and / or equipment if the temperature is not known, and corrections applied as required. Best results will be obtained when the maximum and minimum allowable temperatures for a given process are known, and controls selected to achieve these results.

#### **Types of Controllers:**

##### **Electronic Controllers**

Electronic Controllers receive a signal from a thermocouple or RTD and determine how much heat is needed to control the process. These controllers can range from very simple dial controllers to complex multiloop PID controllers.

Advantages: Very accurate control, digital displays and flexibility for many applications

Disadvantage: More expensive than some mechanical controls.

##### **Bulb & Capillary and Bi-Metal Thermostats**

Mechanical thermostats depend on expanding liquids or metals to open or close contacts in response to temperature changes. Usually, no temperature is displayed, and a calibrated knob is provided on some models. In mechanical controllers, the sensor is part of the controller.

Advantages: Relatively inexpensive. Some bulb and capillary controls can switch large amounts of current for one or more poles (conductors). Easy to set up, just turn the knob for the desired temperature.

Disadvantages: On-off controls sometimes have a large differential or dead band. This is the difference in degrees between turn off and turn on. Your process variation will be greater than the dead band. Bulb and capillary controls do not fail safely. If the capillary tube with the fluid in it becomes pinched or broken, the thermostat will fail in a heat-on condition, which is a hazard. Bi-metal thermostats, which have no bulb or capillary, typically have smaller deadbands, and can control more closely. Some will not operate a contactor, which may be needed to switch the higher currents and voltages needed by the heater. They are often appropriate only for small 120-240V single-phase heaters. Temperature accuracy is inferior to electronic controllers.

#### **Control Modes**

**Manual:** (switch or circuit breaker)

For some applications, such as water pipe freeze protection, circuit breakers are turned on in the Fall and off in the Spring.

Advantages: Low cost, easy operation.

Disadvantages: Possibility of not remembering to turn on equipment in the fall. Energy is wasted when equipment is on if it is not required. Consider an ambient temperature control to switch the equipment on if the temperature is below 40°F.

**Open Loop**(Intensity or duty-cycle control):

## Technical Information

### Control Systems Selection Guidelines (*cont'd.*)

Includes motor driven timers, infinite control bi-metal relays, and SCR controllers with knobs for setting power percentage. Open loop control does not use a sensor to determine the amount of heat needed. The control device is set to a specific percent output and switches the output on and off to approximate the percentage of available heater wattage. Typically used for radiant heat.

Advantages: Low cost, ease of operation.

Disadvantage: Does not compensate for variations in ambient temperatures or incoming product temperatures. Must, in many cases be reset, often after operator observation of poor process results.

#### On Off (bulb & capillary, bi-metal, or electronic) (See Figure 5)

The deadband (Hysteresis) represents an area about set point in which no control action takes place, and determines at what temperature the output switches ON and OFF. Narrow deadband settings give more accurate control but result in more frequent output switching, which can cause early failure of electromechanical contactors. On-Off control is available in electronic, bulb and capillary, and bi-metal controls.

Disadvantage: The control is only as accurate as the deadband. Large overshoots will occur with systems with significant lag.

#### Proportional

Proportional controls reduce the heat output gradually (within the Proportional Band), as the process approaches the set point.

Advantage: More accurate control than On-off control. In stable conditions (constant load), proportional control can maintain a specific temperature. Since they are electronic, with wired sensors, such as thermocouples, the control can sense an open sensor and shut down the process, resulting in a safer control system than mechanical on-off controls.

Disadvantage: Proportional controls work best on stable processes. They have trouble maintaining temperature during process upsets. Some proportional controls can switch significant loads with optional high current relays and solid state switching devices.

#### PID

PID (Proportional, Integral, and Derivative) controls, when properly set up (tuned) can manage most situations, including process upsets. Like a Proportional control, the heat output is gradually reduced while approaching set point, but also with the integral and derivative action can control processes with varying loads at set point. A wide variety of sensors and parameters ensure a good match of control to process. Many PID controllers have autotuning functions that automatically tune to the process.

Advantages: Good overall control. Since they are electronic, with wired sensors, such as thermocouples, the control can sense an open sensor and shut down the process, resulting in a safer control system than mechanical on-off control.

Disadvantages: More costly; more set-up required because of greater flexibility. Requires external power controller to switch the load.

#### *Overtemperature Controls(High Limit Controls):*

(Bulb & capillary, electronic non-indicating, and electronic indicating).

Overtemperature controls provide a safety backup for the primary control and/or the heaters in case of a problem. The overtemperature controller's function is to protect the process or heater. In an overtemperature condition the overtemperature controller will shut down the process. The overtemperature controller cannot be cleared until the process cools and an operator manually resets the controller. It is important to use overtemperature controllers with a shutdown device such as a contactor to protect the heater process and personnel from damage or injury.

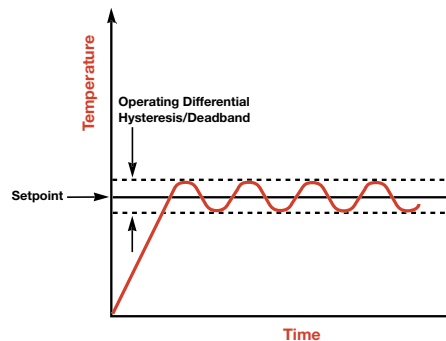
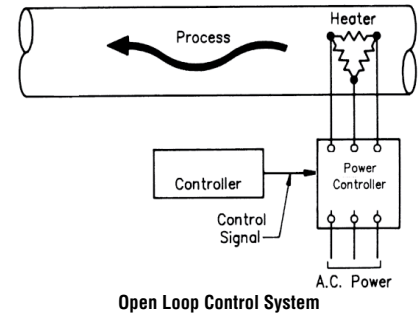

Figure 5

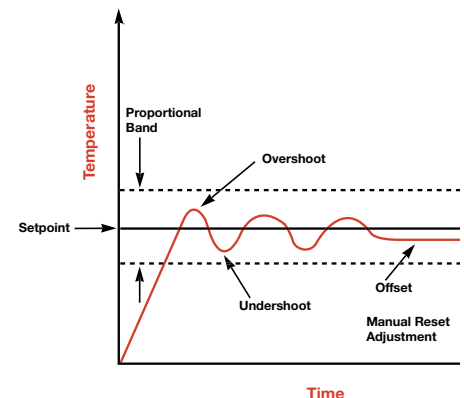

Figure 6

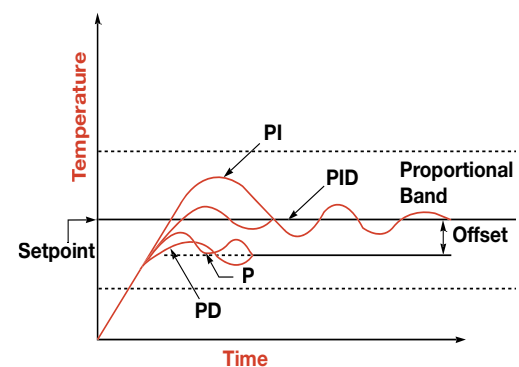

Figure 7

## Technical Information

### Control Systems Selection Guidelines (*cont'd.*)

**Bulb & Capillary Overtemperature Controls** have the same issues as mechanical temperature controls:

Advantages: they are inexpensive and can switch significant power. Most are easy to set up.

Disadvantages: Bulb and capillary controls do not fail safely. If the capillary tube with the fluid in it becomes pinched or broken, the control will not go into an alarm condition, which is a hazard. Knob shows nominal setting, but not process temperature.

**Electronic Non-Indicating Overtemperature Controls:**

Advantages: Inexpensive, easy set up. If power is lost to the controller or the sensor breaks, the overtemperature controller will go into alarm and shut down the process.

Disadvantages: Usually requires an external contactor to switch power. Knob has poor resolution for setting temperature, and there is no way to read process temperature.

**Electronic Indicating Overtemperature Controls:** are microprocessor based units with many sensor choices, and the ability to accurately view set point or process temperature.

Advantages: More set up accuracy, variable deadband. If power is lost to the controller or the sensor breaks, the overtemperature controller will go into alarm and shut down the process.

Disadvantages: Requires a contactor to switch the load. Set up more involved than for bulb and capillary units.

**Level Controls.** If a liquid is being heated, and the possibility exists for the level to fall to the point where the hot section of the heating element could be exposed to air, a level sensor is suggested to prevent damage to area, heater and/or liquid. See the catalog for selection based on your fluid type. Level control should be wired so heater turns off if liquid falls below acceptable level.

**Environmental and Safety Considerations:**

Process controls, overtemperature controls, and accessories must be selected with the surrounding area in mind. Wet, dry, explosion hazard areas must be considered, as well as the ambient temperature range the equipment will see. Mechanical controls should not be exposed to temperatures above the control temperature range. Electronic controls are designed to operate above 32°F, and below a stated maximum, usually 120 or 140°F. See specific control for ambient temperature range.

### *Power Controls*

For small loads (less than 20 amps) some bulb and capillary and electronic controllers can switch the heater directly. For larger loads it is necessary to use an external power controller. There are various mechanical and solid state power controllers available.

### *Types of Power Controls*

#### **Mechanical Contactors**

Mechanical contactors are similar to motor starters. They are capable of switching large amounts of power on an infrequent basis. If turned on and off at a fast rate (more than 1 or 2 times a minute), mechanical wear and contact erosion will require frequent replacement.

Advantages: Low cost. High switching currents. They do not produce much heat from their operation.

Disadvantages: Contactors are subject to mechanical wear, and produce electrical and mechanical noise.

#### **Mercury Displacement Contactors**

Mercury displacement contactors (or mercury contactors) are similar in operation to above mechanical contactors, except mercury is made to move up and down a sealed tube by an external electromagnet, which pulls down a steel core when the coil is energized.

Advantages: Little mechanical noise, long life, with faster on and off cycles (every 10 seconds) than regular mechanical contactors.

Disadvantages: Contains mercury, a hazardous substance, not permitted in some plants. Mercury tubes may rupture during severe over current conditions, releasing the mercury. (Fast semi-conductor fuses minimize this possibility).

#### **Snubbers**

To minimize electrical noise, snubbers should be connected across each contactor coil minimizing arcing of control relay contacts. A Snubber is an electronic circuit, which absorbs the inductive kick back of the contactor coil when it turns off.

**Environmental and Safety Considerations:**

Arcing contactor contacts may ignite flammable vapors. Mercury may be released from mercury contactors.

## Technical Information

### Control Systems Selection Guidelines (*cont'd.*)

#### SCR's

SCRs (Silicon Controlled Rectifiers) are devices used to switch power. Since SCR's are solid state devices with no mechanical moving parts, they are able to switch current quickly without wear. Some SCR devices can switch up to 600VAC at 600 amps. With this switching capability they are used to precisely control single or three phase heater loads. Many different "firing packages" are available to achieve desired results with varying load types and related conditions. "Zero-crossover firing" switches power at the zero voltage or the sine wave almost eliminating EMI and RFI. "Phase-Angle firing" switches anywhere in the sine wave and although it is electrically noisy, it is required for some loads i.e. tungsten, transformer driven load.

SCRs have two major disadvantages over mechanical contactors. 1) SCR's tend to fail shorted (full on). A mechanical disconnect device and overtemperature controller are strongly recommended. SCR's CANNOT BE USED AS A SHUT DOWN DEVICE. 2) SCR's generate heat when current is passed through them (1.5 watts per amp or per leg). For example, an SCR switching a 100Amp load, with 2 legs of a three phase design will generate approximately 300Watts of heat. It is important to include cooling or ventilation in designs using SCR's.

SCR power controllers come in many shapes and sizes. Solid State Relays are the simplest SCR devices. These are generally single phase, low current devices with few special features. More sophisticated and higher amperage SCR power controllers, sometimes called Power Packs, have more features and capabilities.

#### Zero Crossover Firing

Zero-crossover fired SCR's turn on at the zero voltage point of the sine wave. Switching at zero volts means no current is flowing when the switching occurs and therefore little conducted and/or radiated electrical noise is produced. This helps prevent problems with nearby computers and other instrumentation, which may be noise sensitive. Types of zero crossover control are:

- On-Off
- Time Proportional
- DOT

**On-Off Zero-Crossover Control** receives a signal from a remote device to turn on or off. Generally a temperature controller will cycle it's output to approximate a percent output. For example: for a 50% output the controller will turn on the SCR for 1/2 second and turn it off for 1/2 second. The signal from the controller can be a pulsed dc voltage, or a relay contact input.

**Time Proportional Zero-Crossover Control** receives an analog signal (i.e. 4-20mA) from a remote controller or other device. The SCR's time-proportional firing package takes the 4-20mA signal and converts it into a ON and OFF time based on the cycle time. For example, the cycle time is 2 seconds, the signal received is 50%(12mA), the firing package will have the SCR turn on for 1 second and off for one second.

#### DOT (demand oriented transfer) zero-crossover control

The SCR's DOT firing package takes the 4-20mA signal from a remote controller. Demand Oriented Transfer (DOT) is a zero-crossover SCR which varies the on-off time to the smallest possible time base to provide superior resolution and minimum power supply disturbances. For example, a 50% power output can be one cycle on and one off. Considering the incoming supply is 60 cycles per second, the SCR can be turning on and off 30 times a second. DOT firing is the most accurate Zero-Crossover firing method. Zero-Crossover firing also ensures low electrical noise.

#### Phase Angle

A phase angle control splits each half cycle into a percentage needed for the instantaneous load requirements. Phase angle firing is required for tungsten and transformer loads.

Advantages: extremely tight control.

Disadvantages: Electrical noise and power line harmonics are produced during operation. With these noise problems, even though phase angle control is tighter than zero-crossover control it is usually only used when required by the load type.

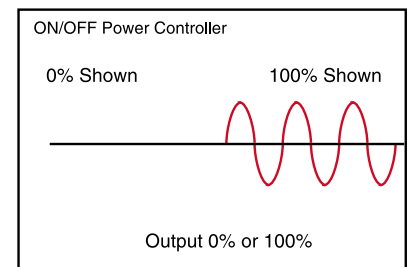

Figure 8

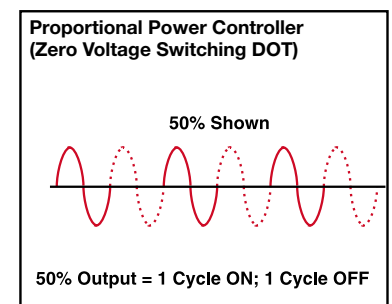

Figure 9

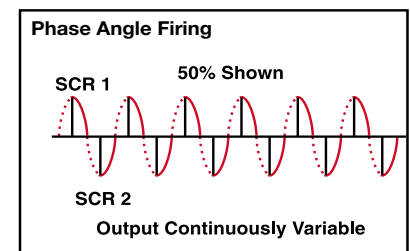

Figure 10

## Technical Information

### Control Systems Selection Guidelines *(cont'd.)*

#### Three Phase Power Control Using SCRs

**2 leg vs. 3 leg** – “Legs” refers to the number of lines switched in a 3-phase SCR circuit. “Two legs” means 2 of the three lines are switched, and the third is passed through un-switched (hot).

Advantage: 2 leg is cheaper than 3 leg switching, since only 2 sets of SCR's are needed, not 3. Only 2/3 as much heat is produced by the SCR's in a 2 leg vs. a 3-leg system. Two leg switching can only be used with zero-crossover SCRs and on Delta or 3 wire Wye loads.

**3 leg for 3 phase loads** – 3 leg control is required for any 4 wire Wye load and for any 3-phase angle fired applications.

#### ***Environmental and Safety Considerations:***

Power controls, and accessories must be selected with the surrounding area in mind. Wet, dry, and explosion hazard areas must be considered, as well as the ambient temperature range the equipment will operate in. SCR controls are designed to operate above 32°F, and below a stated maximum, usually 100 to 120°F. See specific SCR for allowable ambient. Heat produced by the SCR's must be removed. This is usually done with ventilation, fans, air conditioners or heat sinks mounted on the outside of the enclosure. Even if the SCR has a built-in fan, ample air changes in the panel must be provided, perhaps by an additional fan, to keep inside of panel below maximum allowable ambient for the components inside, for the highest expected external ambient.

#### Choosing a Power Control

##### Electrical Considerations

Contactors must be selected for voltage and current of load(s). If you have three 3 phase, 30 Amp loads, for example, 3 small contactors may take up less space than one large contactor, and would be more cost effective.

SCR's should be selected / specified based on the voltage, total current of the load(s) and the number phases. For a 3-phase delta circuit a 2-leg unit can be used, for 3-phase 4 wire circuits, or phase-angle control, 3 leg SCR's are required. Be sure to use I<sup>2</sup>T fuses (fast blow) to protect the SCR's.

#### ***Environmental and Safety Considerations:***

Power controls and accessories must be selected with the surrounding area in mind. Wet, dry, explosion hazard areas must be considered, as well as the ambient temperature range the equipment will experience. Panels generally require internal heaters, if the ambient is below 32°F. In addition, the maximum ambient should be considered and taken into account. This is particularly important for SCR panels, since the SCR's generate heat, which must be removed during operation. Panels should not be mounted where they will receive direct sunlight.

#### ***Power Control Panels***

Power Control Panels are assembled systems which combine temperature control, overtemperature control, contactors, SCRs and other components into a prewired complete control system.

#### Stock Panels

Chromalox has a good selection of “off the shelf” stock Contactor, SCR and Heat Trace panels. Features include, NEMA 4X Fiberglass® enclosure, contactors of 40, 75, or 90 Amp rating. Optional temperature controls, overtemperature controls and disconnects are also available.

#### Standard Design Panels

Chromalox has pre-designed panels of several series, both SCR and contactor, with NEMA 1, 4, 4X, and 7 ratings. Many choices of voltages, currents, branch circuit fusing and controls are offered. Consideration is given to heat dissipation, environments and safety requirements.

#### Custom Design Panels

Chromalox is ready to design and manufacture your custom panel as a variation of one of our standard panels or full custom from scratch. Many additional features are available. We can incorporate motor starter relays for pumps and fans, as well as use specific brand controls to meet plant specifications. Chromalox has a UL approved panel-shop and can also make panels to military specifications. Chromalox' instrument, control and panel shops are ISO-9001.

#### Choosing a Panel

Panel should be selected/specified based on the voltage, current, and number of circuits of the load(s). Panel must be compatible with the area classification (ex. NEMA 4) where it is to be located.

#### Loads, Circuit Protection

The National Electrical Code (NEC) requires load circuit protection for all circuits and branch circuits. HVAC heating applications further require that all sub circuits not exceed 48 amps.



## Technical Information

### Control Systems Selection Guidelines (*cont'd.*)

Advantages: Keeps wire sizes reasonable, and allows for more reliable operation. If one circuit shorts, the others can usually continue to operate, if fused separately.

#### **Wiring Issues**

Chromalox panels are compliant with the NEC. The installer is responsible for applying NEC and all local codes. The connection to the heater may require special high temperature wire at least within several feet of the heater, to prevent wire insulation damage, and / or conductor oxidation.

#### ***Environmental and Safety Considerations:***

Panels and accessories must be selected with the surrounding area in mind. Wet, dry, explosion hazard areas must be considered, as well as the ambient temperature range the equipment will operate in. Panels generally require an internal heater, if the ambient is below 32°F. In addition, the maximum ambient should be considered and taken into account. This is particularly important for SCR panels, since the SCR's generate heat during operation. Panels should never be mounted where they will receive direct sunlight. Outdoor installations require shading.

#### **Building a Panel**

##### **Choosing Controllers and Power Controls**

Temperature controls, overtemperature controls, and power controls must be chosen based on process temperature range, process speed, area classification, ambient temperature, (minimum and maximum), voltage and current.

##### **Heat and Cold Management**

While heat is the usual panel load, it is the enemy inside of a panel. This is especially true for SCR panels. Fans must be provided to remove heat generated, and ensure that the temperature inside the panel does not exceed the maximum operating ambient for the power controls and other components. For wet, dusty, or explosion areas, consider mounting the panel in a clean, dry control room away from contaminants. There are different standard models of Chromalox panels that are built with these considerations. All include specifications of maximum ambient temperature outside the enclosure.

##### **Layout Considerations**

Panel layout must follow NEC and local codes. Ample room must be provided for all components, and bend radii of the wiring. Door mounted components must clear sub-panel mounted components. Wiring must allow for easy door opening for access. A disconnect should be provided to permit safe access to panel components for servicing. All Chromalox Panels meet NEC codes.

#### ***Environmental and Safety Considerations:***

Panels and accessories must be selected with the surrounding area in mind. Wet, dry, explosion hazard areas must be considered, as well as the ambient temperature range the equipment will operate in. Panels generally require an internal heater if the ambient is below 32°F. In addition, the maximum ambient should be considered and taken into account. This is particularly important for SCR panels, since the SCR's generate heat during operation. Panels should not be mounted where they will receive direct sunlight.

**Chromalox® , Inc. is pleased to offer suggestions on the use of its products. However, Chromalox® , Inc. neither assumes responsibility for any omissions or errors nor assumes liability for any damages that result from the use of its products in accordance with information provided by Chromalox® , Inc., either verbal or written.**