

User's Manual

PROHEAT *Controls*

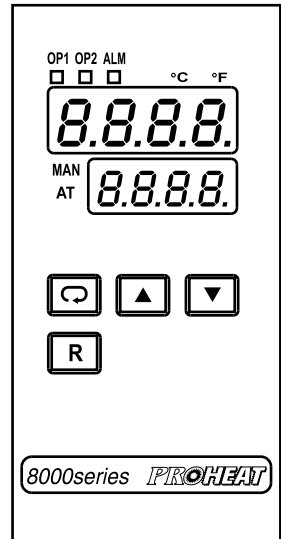
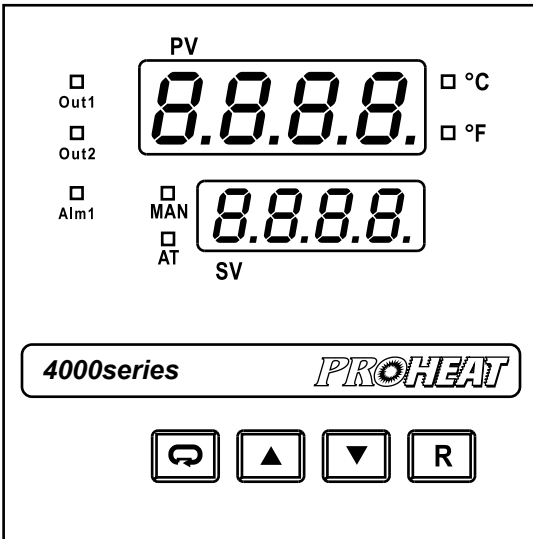
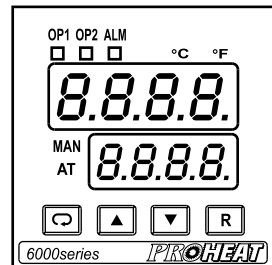

4000 Series 1/4 DIN
6000 Series 1/16 DIN
8000 Series 1/8 DIN

Auto-Tune Fuzzy / PID
Process / Temperature Controller



PROHEAT
Industrial Heaters, Sensors & Controls

117 East Adam Street LaGrange, KY 40031
502 222-1402 Fax: 502 222-0714
www.proheatinc.com

Warning Symbol

This Symbol calls attention to an operating procedure, practice, or the like, which, if not correctly performed or adhered to, could result in personal injury or damage to or destruction of part or all of the product and system. Do not proceed beyond a warning symbol until the indicated conditions are fully understood and met.

Use the Manual

- Installers Read Chapter 1, 2
- System Designer Read All Chapters
- User Read Page 12

NOTE:

It is strongly recommended that a process should incorporate a LIMIT CONTROL which will shut down the equipment at a preset process condition in order to preclude possible damage to products or system.

Information in this user's manual is subject to change without notice.

Copyright January 2018, Proheat Inc., all rights reserved. No part of this publication may be reproduced, transmitted, transcribed or stored in a retrieval system, or translated into any language in any form by any means without the written permission of Proheat Inc.

Quick Reference Guide

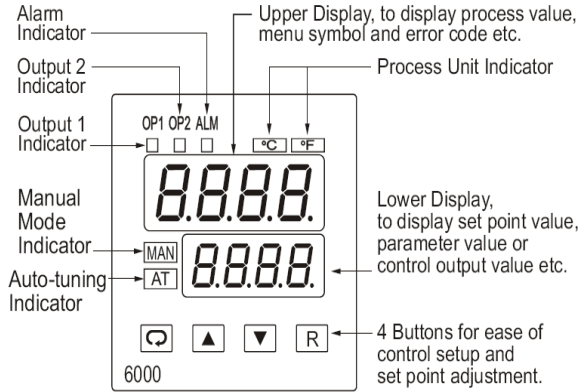

KEYPAD OPERATION

SCROLL KEY :

This key is used to select a parameter to be viewed or adjusted.

UP KEY :

This key is used to increase the value of selected parameter.

DOWN KEY :

This key is used to decrease the value of selected parameter.

RESET KEY :

This key is used to:

1. Revert the display to the process value.
2. Reset the latching alarm, once the alarm condition is removed.
3. Stop the manual control mode , auto-tuning mode and calibration mode.
4. Clear the message of communication error and auto-tuning error.
5. Restart the dwell timer when the dwell timer has timed out.
6. Enter the manual control menu during failure mode.

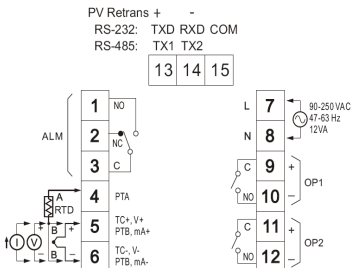
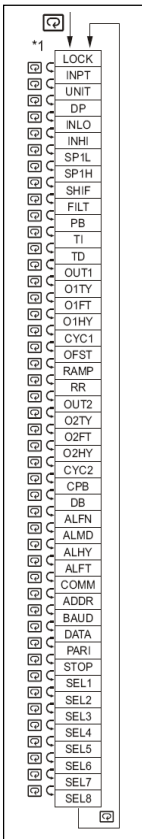

Figure 2.6
Rear Terminal Connection for 6000 Series

ADJUSTMENT SEQUENCE	SYMPTOM	SOLUTION
(1) Proportional Band (PB)	Slow Response	Decrease PB
	High overshoot or Oscillations	Increase PB
(2) Integral Time (TI)	Slow Response	Decrease TI
	Instability or Oscillations	Increase TI
(3) Derivative Time (TD)	Slow Response or Oscillations	Decrease TD
	High Overshoot	Increase TD

PID Adjustment Guide



Set-up Menu

Press key for 3 seconds to enter the set-up menu.

The flow chart shows a complete listing of all parameters. The number of available parameters depends on setup conditions, and should be less than that shown in the flow chart.

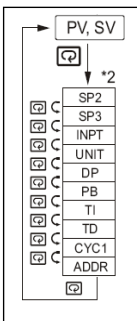

User Menu

This series control has the flexibility for you to select those parameters which are most significant to your application. These parameters are able to be put in the front of the display sequence for ease of access.

Select the parameters for view in the user menu by using SEL1 – SEL8 contained at the bottom of the set-up menu.

Parameter Notation	Parameter Description	Default Value
SP1	Set point for output 1	77.0°F
SP2	Set point for output 2	18.0°F
SP3	Set point for alarm	18.0°F
LOCK	Select parameters to be locked	None
INPT	Input sensor selection	Type J
UNIT	Input unit selection	*F
DP	Decimal point selection	1 digit
INLO	Input low scale value	0°F
INHI	Input high scale value	200.0°F
SP1L	Low limit of set point value	0°F
SP1H	High limit of set point value	1000°F
SHIF	PV shift value	0.0
FILT	Filter damping time	5 sec
PB	Proportional band value	18.0°F
TI	Integral time value	100
TD	Derivative time value	25.0
OUT1	Output 1 function	Heating
O1TY	Output 1 signal type	Relay
O1FT	Output 1 failure transfer mode	Off
O1HY	Output 1 hysteresis	0.2°F
CYC1	Output 1 cycle time	18.0
OFST	Offset value for P control	25.0
RAMP	Ramp function selection	None
RR	Ramp rate	0.0
OUT2	Output 2 function	Dev Hi alarm
O2TY	Output 2 signal type	Relay
O2FT	Output 2 failure transfer mode	Off
O2HY	Output 2 hysteresis	0.2°F
CYC2	Output 2 cycle time	18.0
CPB	Cooling prop band value	100
DB	Heating-cooling dead band	0
ALFN	Alarm function	Dev hi alarm
ALMD	Alarm operation mode	Normal
ALHY	Hysteresis control of alarm	Normal
ALFT	Alarm failure transfer mode	On
COMM	Communication function	Modbus
ADDR	Address assignment	-
BAUD	Baud rate	9.6
DATA	Data bit count	8
PARI	Parity bit	Even
STOP	Stop bit count	1
RELO	PV retransmission low value	0°F
REHI	PV retransmission high value	200.0°F
SEL1	1st parameter for user menu	INPT
SEL2	2nd parameter for user menu	UNIT
SEL3	3rd parameter for user menu	DP
SEL4	4th parameter for user menu	PB
SEL5	5th parameter for user menu	TI
SEL6	6th parameter for user menu	TD
SEL7	7th parameter for user menu	CYC1
SEL8	8th parameter for user menu	ADDR

Quick Reference Guide

Quick Reference Guide

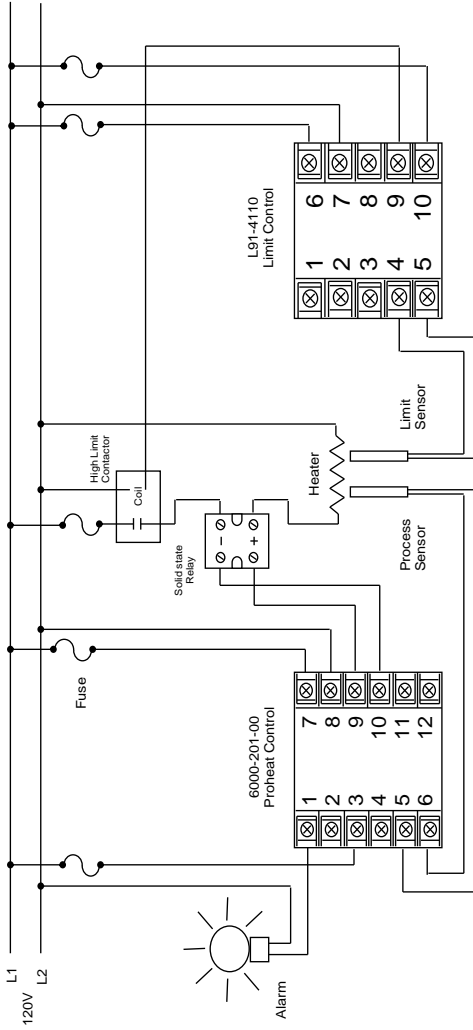

**Example System Wiring Diagram
Solid State Relay**

Quick Reference Guide

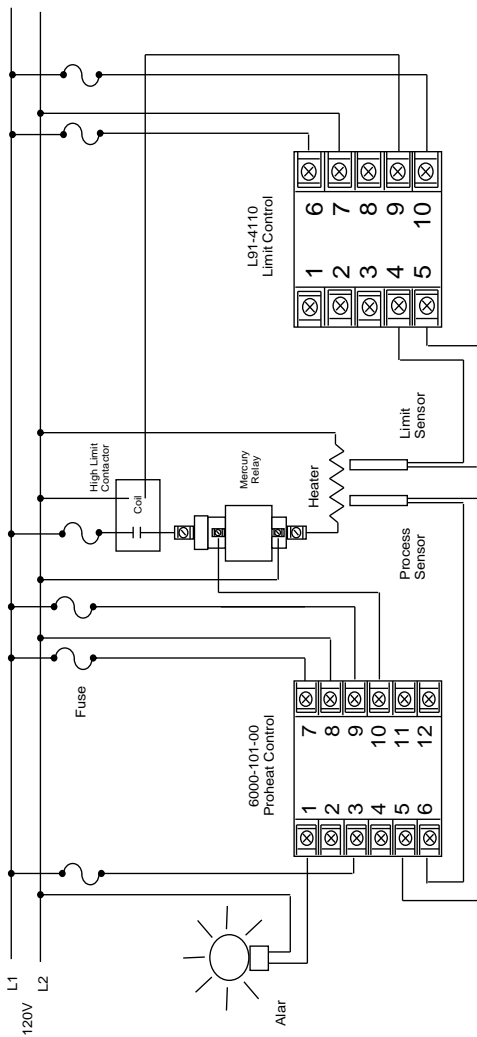

**Example System Wiring Diagram
Mercury Relay**

Contents

	Page No		Page No
Chapter 1 Overview		Chapter 4 Calibration	-----48
1-1 General	-----4	Chapter 5 Specifications	---53
1-2 Ordering Code	-----7	Appendix	
1-3 Programming Port	-----8	A-1 Error Codes	-----59
1-4 Keys and Displays	-----9	A-2 Warranty	-----60
1-5 Menu Overview	-----11		
1-6 Parameter Descriptions	---12		
Chapter 2 Installation			
2-1 Unpacking	-----19		
2-2 Mounting	-----19		
2-3 Wiring precautions	-----21		
2-4 Power Wiring	-----24		
2-5 Sensor Installation			
Guidelines	-----24		
2-6 Sensor Input Wiring	-----25		
2-7 Control Output Wiring	-----25		
2-8 Alarm Wiring	-----28		
2-9 Process Retransmission	----28		
2-10 Data Communications	-----29		
Chapter 3 Programming			
3-1 Lockout	-----31		
3-2 Signal Input	-----31		
3-3 Control Outputs	-----32		
3-4 Alarm	-----37		
3-5 Configure User Menu	----38		
3-6 Ramp	-----39		
3-7 Dwell Timer	-----40		
3-8 PV Shift	-----41		
3-9 Digital Filter	-----41		
3-10 Failure Transfer	-----42		
3-11 Auto-tuning	-----43		
3-12 Manual tuning	-----44		
3-13 Manual Control	-----45		
3-14 Data communication	----47		
3-15 PV Retransmission	----47		

Chapter 1 Overview

1-1 General

The Fuzzy Logic plus PID microprocessor-based controller series, incorporate two bright, easy to read 4-digit LED displays, indicating process value and set point value. The Fuzzy Logic technology enables a process to reach a predetermined set point in the shortest time, with the minimum of overshoot during power-up or external load disturbance.

SERIES 6000 is a 1/16 DIN size panel mount controller. SERIES 4000 is a 1/4 DIN size panel mount controller. SERIES 8000 is a 1/8 DIN size panel mount controller. These units are powered by 11-26VAC/VDC or 90-250 VAC supply, incorporating a 2 amp. control relay output as standard. The second output can be used as cooling control, or an alarm. Both outputs can select triac, 5V logic output, linear current or linear voltage to drive external device. There are six types of alarm plus a dwell timer can be configured for the third output. The units are fully programmable for PT100 and thermocouple types J,K, T, E, B, R, S, N, L with no need to modify the unit. The input signal is digitized by using a 18-bit A to D converter. Its fast sampling rate, 5 scans/second, allows the unit to control with greater accuracy and response time.

Digital communications RS-485 or RS-232 are available as an additional option. These options allow the units to be integrated with supervisory control system and software.

A programming port is available for automatic configuration, calibration and testing without the need to access the keys on front panel.

By using proprietary Fuzzy modified PID technology, the control loop will minimize the overshoot and undershoot in a shortest time. The following diagram is a comparison of results with and without Fuzzy technology.

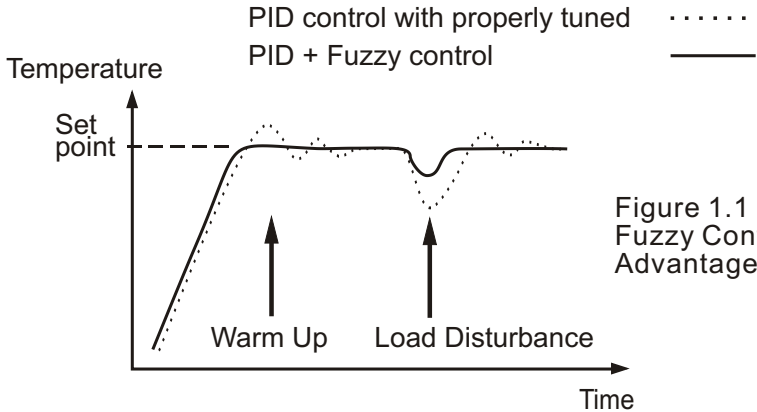

Figure 1.1
Fuzzy Control
Advantage

High Accuracy

This Series controllers are manufactured with custom designed ASIC(Application Specific Integrated Circuit) technology which contains a 18-bit A to D converter for high resolution measurement (true 0.1 F resolution for thermocouple and PT100) and a 15-bit D to A converter for linear current or voltage control output. The ASIC technology provides improved operating performance, low cost, enhanced reliability.

Fast Sampling Rate

The sampling rate of the input A to D converter reaches 5 times/second. The fast sampling rate allows this series to control fast processes.

Fuzzy Control

The function of Fuzzy control is to adjust PID parameters from time to time in order to make manipulation output value more flexible and adaptive to various processes. The results is to enable a process to reach a predetermined set point in the shortest time, with the minimum of overshoot and undershoot during power-up or external load disturbance.

Digital Communication

The units are equipped with RS-485 or RS-232 interface card to provide digital communication. By using the twisted pair wires there are at most 247 units can be connected together via RS-485 interface to a host computer.

Programming Port

A programming port is used to connect the unit to a hand-held programmer or a PC for quick configuration, also can be connected to an ATE system for automatic testing & calibration.

Auto-tune

The auto-tune function allows the user to simplify initial setup for a new system. A sophisticated algorithm is provided to obtain an optimal set of control parameters for the process, and it can be applied either as the process is warming up (cold start) or as the process has been in steady state (warm start).

Lockout Protection

According to your security requirements, one of four lockout levels can be selected to prevent unauthorized changes.

Bumpless Transfer

Bumpless transfer allows the controller to continue to control by using its previous values if a sensor fails.

Soft-start Ramp

The ramping function is performed during power up as well as any time the set point is changed. It can be ramping up or ramping down. The process value will reach the set point with a predetermined constant rate.

Digital Filter

A first order low pass filter with a programmable time constant is used to improve the stability of process value. This is particularly useful in certain application where the process value is unstable.

SEL Function

The units have the flexibility to select parameters which are most significant so as to put these parameters in the front of display sequence. There are 8 parameters that can be selected to allow the user to build a custom display sequence.

1-2 Ordering Code

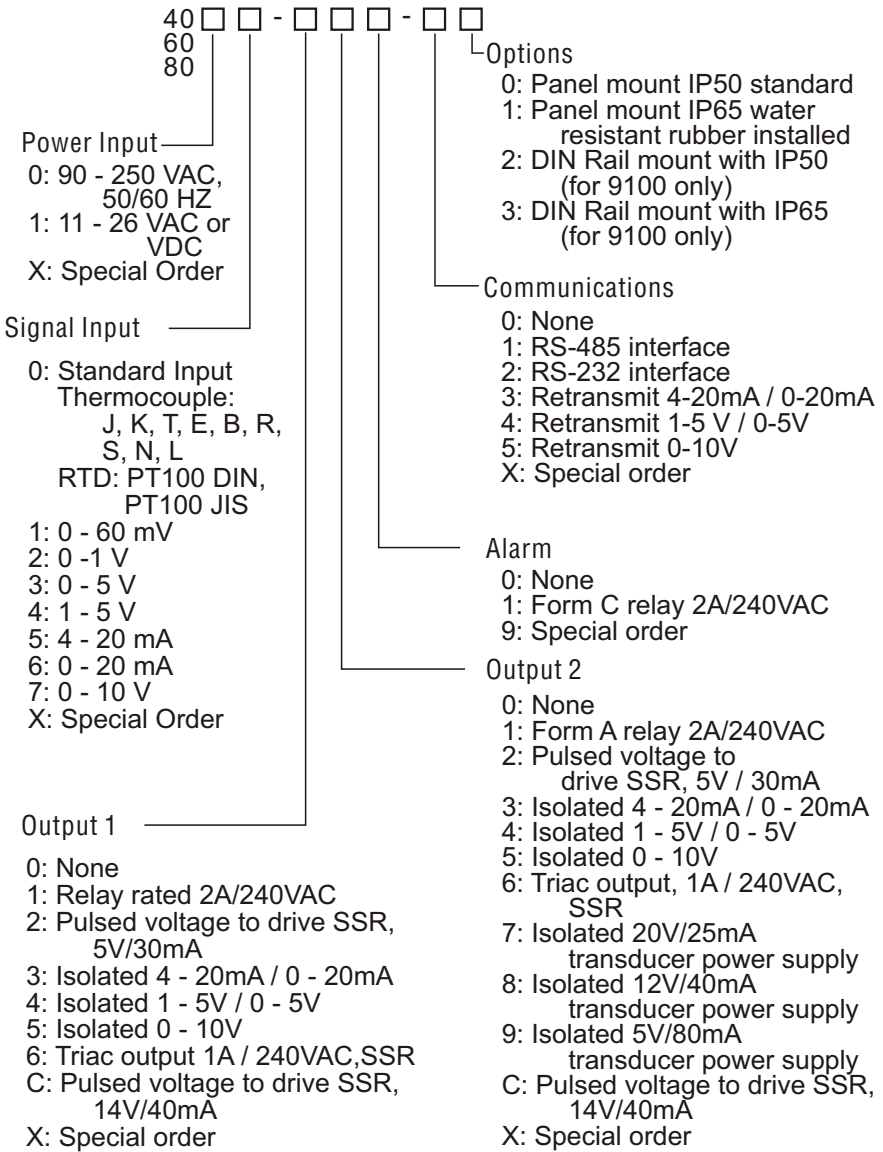

1-3 Programming Port

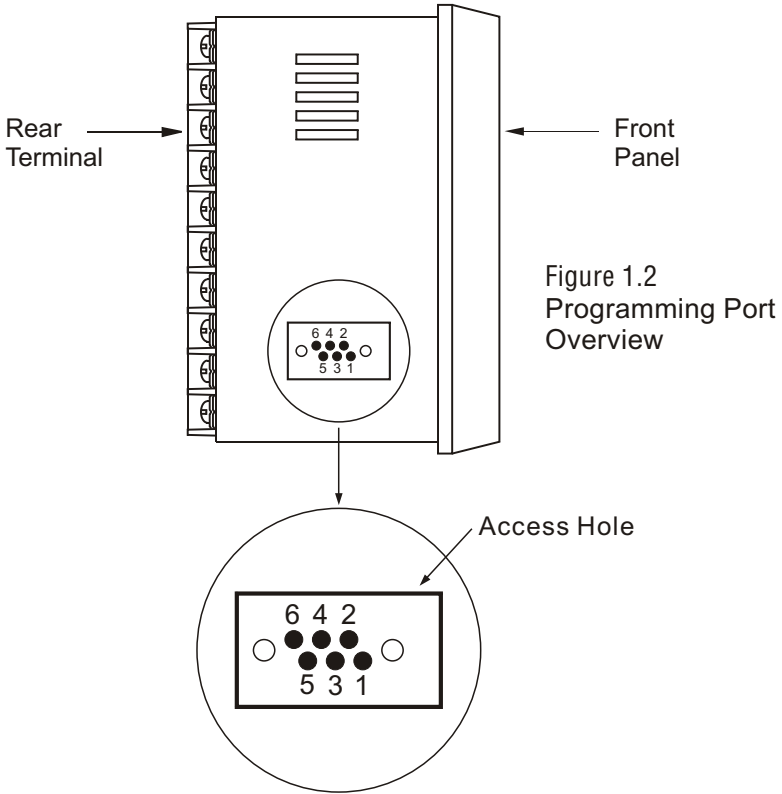

Figure 1.2
Programming Port
Overview

A special connector can be used to touch the programming port which is connected to a PC for automatic configuration, also can be connected to an ATE system for automatic calibration and testing.

The programming port is used for off-line automatic setup and testing procedures only. Do NOT attempt to make any connection to these pins when the unit is in normal operation.

1- 4 Keys and Displays

KEYPAD OPERATION

SCROLL KEY : 

This key is used to select a parameter to be viewed or adjusted.

UP KEY : 

This key is used to increase the value of selected parameter.

DOWN KEY : 

This key is used to decrease the value of selected parameter.



RESET KEY : 

This key is used to:

1. Revert the display to display the process value.
2. Reset the latching alarm, once the alarm condition is removed.
3. Stop the manual control mode , auto-tuning mode and calibration mode.
4. Clear the message of communication error and auto-tuning error.
5. Restart the dwell timer when the dwell timer has been time out.
6. Enter the manual control menu during failure mode occurs.

ENTER KEY : Press  for 3 seconds or longer .

Press  for 3 seconds to:

1. Enter setup menu. The display shows .
2. Enter manual control mode during manual control mode  is selected.
3. Enter auto-tuning mode during auto-tuning mode  is selected.
4. Perform calibration to a selected parameter during the calibration procedure.

Press  for 4.2 seconds to select manual control mode.

Press  for 5.4 seconds to select auto-tuning mode.

Press  for 6.6 seconds to select calibration mode.

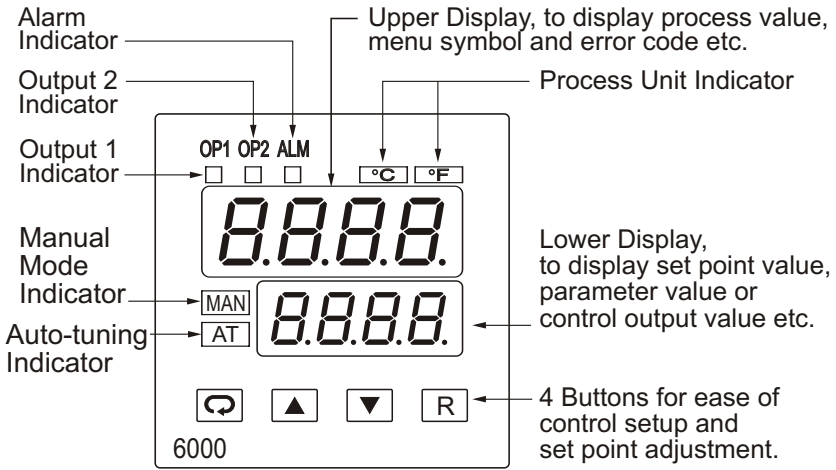
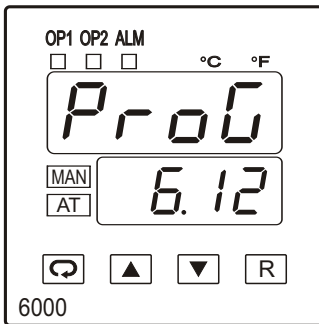

Figure 1.3 Front Panel Description

Table 1.1 Display Form of Characters

A	<i>A</i>	E	<i>E</i>	I	<i>I</i>	N	<i>n</i>	S	<i>S</i>	X	
B	<i>b</i>	F	<i>F</i>	J	<i>J</i>	O	<i>o</i>	T	<i>t</i>	Y	<i>y</i>
C	<i>C</i>	G	<i>G</i>	K	<i>K</i>	P	<i>P</i>	U	<i>u</i>	Z	
c	<i>c</i>	H	<i>H</i>	L	<i>L</i>	Q		V	<i>v</i>	?	<i>?</i>
D	<i>d</i>	h	<i>h</i>	M	<i>m</i>	R	<i>r</i>	W		=	<i>=</i>

↗: Confused Character



Display program code of the product for 2.5 seconds.

The left diagram shows program no. 6 for 6000 Series with version 12.

The program no. for 4000 Series is 12 and the number for the 8000 Series is 11.

Figure 1.4 Display of Initial Stage

1- 5 Menu Overview

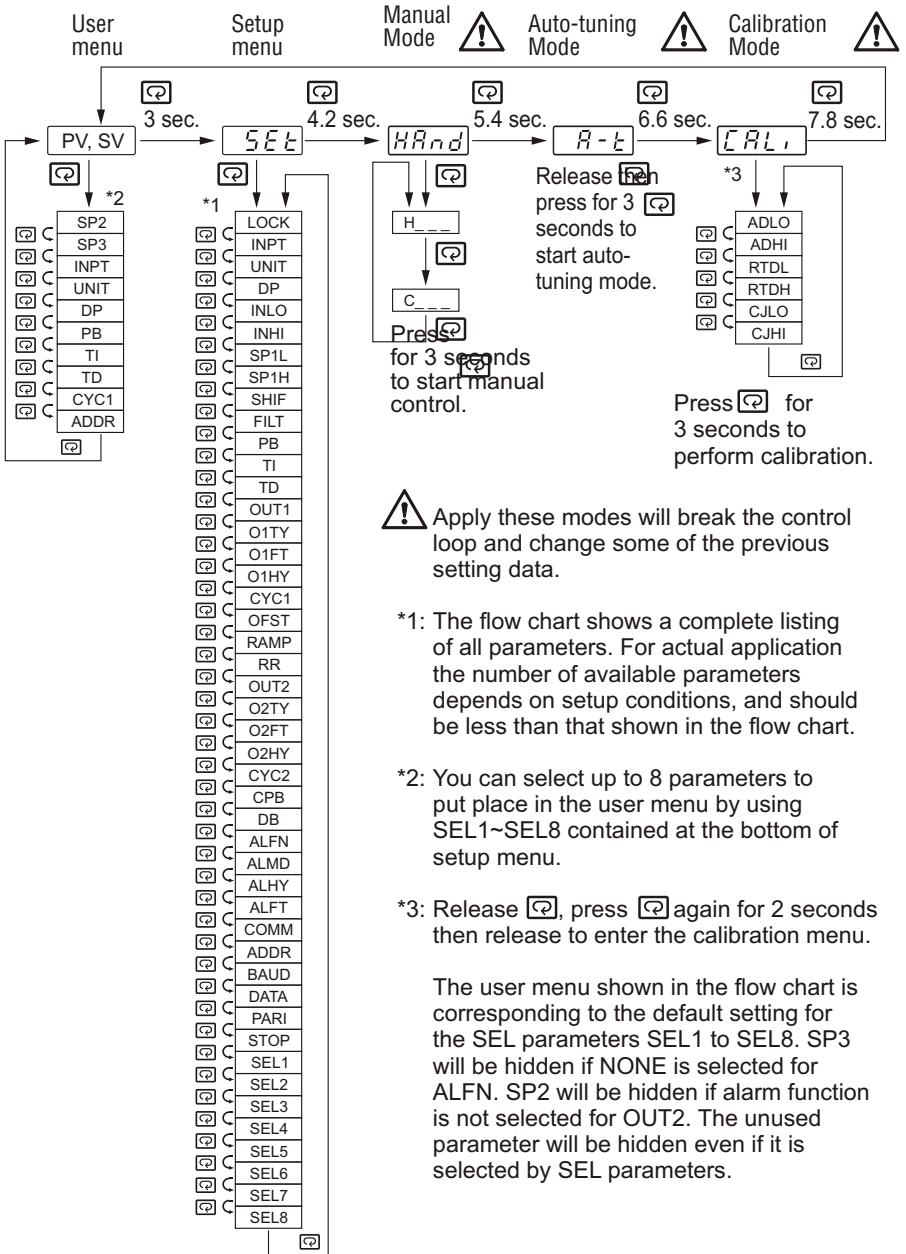

! Apply these modes will break the control loop and change some of the previous setting data.

*1: The flow chart shows a complete listing of all parameters. For actual application the number of available parameters depends on setup conditions, and should be less than that shown in the flow chart.

*2: You can select up to 8 parameters to put place in the user menu by using SEL1~SEL8 contained at the bottom of setup menu.

*3: Release [button], press [button] again for 2 seconds then release to enter the calibration menu.

The user menu shown in the flow chart is corresponding to the default setting for the SEL parameters SEL1 to SEL8. SP3 will be hidden if NONE is selected for ALFN. SP2 will be hidden if alarm function is not selected for OUT2. The unused parameter will be hidden even if it is selected by SEL parameters.

1-6 Parameter Descriptions

Parameter Notation	Parameter Description	Range	Default Value
SP1	Set point for output 1	Low: SP1L High :SP1H	25.0 C (77.0 F)
SP2	Set point for output 2 when output 2 performs alarm function	Low: -19999 High :45536	10.0 C (18.0 F)
SP3	Set point for alarm or dwell timer output	Low: -19999 High: 45536	10.0 C (18.0 F)
LOCK	Select parameters to be locked	0 <i>nonE</i> : No parameter is locked 1 <i>SEt</i> : Setup data are locked 2 <i>uSEr</i> : Setup data and User data except Set point are locked 3 <i>ALL</i> : All data are locked	0
INPT	Input sensor selection NOTE; ← Input Selection 11 - 17 of Linear (ma/VDC) Require special order only See Matrix Page 8. ←	0 <i>J-tC</i> : J type thermocouple 1 <i>K-tC</i> : K type thermocouple 2 <i>T-tC</i> : T type thermocouple 3 <i>E-tC</i> : E type thermocouple 4 <i>B-tC</i> : B type thermocouple 5 <i>R-tC</i> : R type thermocouple 6 <i>S-tC</i> : S type thermocouple 7 <i>N-tC</i> : N type thermocouple 8 <i>L-tC</i> : L type thermocouple 9 <i>Pt100</i> : PT 100 ohms DIN curve 10 <i>Pt100</i> : PT 100 ohms JIS curve 11 <i>4-20</i> : 4 - 20 mA linear current input 12 <i>0-20</i> : 0 - 20 mA linear current input 13 <i>0-60</i> : 0 - 60 mV linear millivolt input 14 <i>0-1V</i> : 0 - 1V linear voltage input 15 <i>0-5V</i> : 0 - 5V linear voltage input 16 <i>1-5V</i> : 1 - 5V linear voltage input 17 <i>0-10V</i> : 0 - 10V linear voltage input	1 (0)

Parameter Notation	Parameter Description	Range	Default Value
UNIT	Input unit selection	0 0C : Degree C unit 1 0F : Degree F unit 2 Pu : Process unit	0 (1)
DP	Decimal point selection	0 noDP : No decimal point 1 1-dP : 1 decimal digit 2 2-dP : 2 decimal digits 3 3-dP : 3 decimal digits	1
INLO	Input low scale value	Low: -19999 High: 45486	-17.8 C (0 F)
INHI	Input high scale value	Low: INLO+50 High: 45536	93.3 C (200.0 F)
SP1L	Low limit of set point value	Low: -19999 High: 45536	-17.8 C (0 F)
SP1H	High limit of set point value	Low: SP1L High: 45536	537.8 C (1000 F)
SHIF	PV shift (offset) value	Low: -200.0 C (-360.0 F) High: 200.0 C (360.0 F)	0.0
FILT	Filter damping time constant of PV	0 0 : 0 second time constant 1 0.2 : 0.2 second time constant 2 0.5 : 0.5 second time constant 3 1 : 1 second time constant 4 2 : 2 seconds time constant 5 5 : 5 seconds time constant 6 10 : 10 seconds time constant 7 20 : 20 seconds time constant 8 30 : 30 seconds time constant 9 60 : 60 seconds time constant	2

Parameter Notation	Parameter Description	Range	Default Value
PB	Proportional band value	Low: 0 High: 500.0 C (900.0 F)	10.0 C (18.0 F)
TI	Integral time value	Low: 0 High: 1000 sec	100
TD	Derivative time value	Low: 0 High: 360.0 sec	25.0
OUT1	Output 1 function	0 <i>rEYr</i> : Reverse (heating) control action 1 <i>dirb</i> : Direct (cooling) control action	0
O1TY	Output 1 signal type	0 <i>rELY</i> : Relay output 1 <i>SSrd</i> : Solid state relay drive output 2 <i>SSr</i> : Solid state relay output 3 <i>4-20</i> : 4-20 mA current module 4 <i>0-20</i> : 0 - 20 mA current module 5 <i>0-1V</i> : 0 - 1V voltage module 6 <i>0-5V</i> : 0 - 5V voltage module 7 <i>1-5V</i> : 1 - 5V voltage module 8 <i>0-10</i> : 0 - 10V voltage module	0
O1FT	Output 1 failure transfer mode	Select BPLS (bumpless transfer) or 0.0 ~ 100.0 % to continue output 1 control function as the unit fails, or select OFF (0) or ON (1) for ON-OFF control.	0
O1HY	Output 1 ON-OFF control hysteresis	Low: 0.1 High: 50.0 C (90.0 F)	0.1C (0.2 F)
CYC1	Output 1 cycle time	Low: 0.1 High: 90.0 sec.	18.0
OFST	Offset value for P control	Low: 0 High: 100.0 %	25.0
RAMP	Ramp function selection	0 <i>nonE</i> : No Ramp Function 1 <i>n̄i nr</i> : Use unit/minute as Ramp Rate 2 <i>Hrr</i> : Use unit/hour as Ramp Rate	0

Parameter Notation	Parameter Description	Range	Default Value
RR	Ramp rate	Low: 0 High: 500.0 C (900.0 F)	0.0
OUT2	Output 2 function	0 <i>nonE</i> : Output 2 No Function 2 <i>dEH_i</i> : Deviation High Alarm 3 <i>dEL_o</i> : Deviation Low Alarm 6 <i>P_uHi</i> : Process High Alarm 7 <i>P_uLo</i> : Process Low Alarm 8 <i>Cool</i> : Cooling PID Function	2
O2TY	Output 2 signal type	0 <i>rELY</i> : Relay output 1 <i>SSrd</i> : Solid state relay drive output 2 <i>SSr</i> : Solid state relay output 3 <i>4-20</i> : 4 - 20 mA current module 4 <i>0-20</i> : 0 - 20 mA current module 5 <i>0-1V</i> : 0 - 1V voltage module 6 <i>0-5V</i> : 0 - 5V voltage module 7 <i>1-5V</i> : 1 - 5V voltage module 8 <i>0-10</i> : 0 - 10V voltage module	0
O2FT	Output 2 failure transfer mode	Select BPLS (bumpless transfer) or 0.0 ~ 100.0 % to continue output 2 control function as the unit fails, or select ON (0) or OFF (1) for alarm function.	0
O2HY	Output 2 hysteresis value when output 2 performs alarm function	Low: 0.1 High: 50.0 C (90.0 F)	0.1 C (0.2 F)
CYC2	Output 2 cycle time	Low: 0.1 High: 90.0 sec.	18.0
CPB	Cooling proportional band value	Low: 50 High: 300 %	100

Parameter Notation	Parameter Description	Range	Default Value
DB	Heating-cooling dead band (negative value=overlap)	Low: -36.0 High: 36.0 %	0
ALFN	Alarm function for alarm output	0 <i>nonE</i> :No alarm function 1 <i>t, nr</i> :Dwell timer action 2 <i>dEH, :</i> Deviation high alarm 3 <i>dELo</i> :Deviation low alarm 4 <i>dbH, :</i> Deviation band out of band alarm 5 <i>dbLo</i> :Deviation band in band alarm 6 <i>PuH, :</i> Process value high alarm 7 <i>PuLo</i> :Process value low alarm	2
ALMD	Alarm operation mode	0 <i>norñ</i> : Normal alarm action 1 <i>Ltch</i> : Latching alarm action 2 <i>Hold</i> : Hold alarm action 3 <i>LtHo</i> : Latching & Hold action	0
ALHY	Hysteresis control of alarm	Low: 0.1 High: 50.0 C (90.0 F)	0.1 C (0.2 F)
ALFT	Alarm failure transfer mode	0 <i>on</i> : Alarm output ON as unit fails 1 <i>off</i> : Alarm output OFF as unit fails	0
COMM	Communication function	0 <i>nonE</i> : No communication 1 <i>rtu</i> : Modbus RTU mode protocol 2 <i>4-20</i> : 4 - 20 mA PV Retransmission 3 <i>0-20</i> : 0 - 20 mA PV retransmission 4 <i>0-5V</i> : 0 - 5 VDC PV Retransmission 5 <i>1-5V</i> : 1 - 5 VDC PV Retransmission 6 <i>0-10</i> : 0 - 10 VDC PV Retransmission	1

Parameter Notation	Parameter Description	Range		Default Value
ADDR	Address assignment of digital communication	Low: 1	High: 255	—
BAUD	Baud rate of digital communication	0	2.4 : 2.4 Kbits/s baud rate	2
		1	4.8 : 4.8 Kbits/s baud rate	
		2	9.6 : 9.6 Kbits/s baud rate	
		3	14.4 : 14.4 Kbits/s baud rate	
		4	19.2 : 19.2 Kbits/s baud rate	
		5	28.8 : 28.8 Kbits/s baud rate	
		6	38.4 : 38.4 Kbits/s baud rate	
DATA	Data bit count of digital communication	0	7 bit : 7 data bits	1
		1	8 bit : 8 data bits	
PARI	Parity bit of digital communication	0	Even parity	0
		1	odd : Odd parity	
		2	none : No parity bit	
STOP	Stop bit count of digital communication	0	1 bit : One stop bit	0
		1	2 bit : Two stop bits	
RELO	PV Retranmission Low Value	Low: -19999	High: 45486	-17.8 C (0 F)
REHI	PV Retranmission High Value	Low: -19999	High: 45486	93.3 C (200.0 F)
SEL1	Select 1'st parameter for user menu	0	none : No parameter selected	2
		1	LOCK : LOCK is put ahead	
		2	INPT : INPT is put ahead	
		3	UNIT : UNIT is put ahead	
		4	DP : DP is put ahead	
		5	SHIF : SHIF is put ahead	
		6	PB : PB is put ahead	
		7	TI : TI is put ahead	

Parameter Notation	Parameter Description	Range	Default Value
SEL1	Select 1'st parameter for user menu	8 <i>td</i> :TD is put ahead 9 <i>o1HY</i> : O1HY is put ahead 10 <i>CYC1</i> : CYC1 is put ahead 11 <i>oFSt</i> : OFST is put ahead 12 <i>rr</i> :RR is put ahead 13 <i>o2HY</i> :O2HY is put ahead 14 <i>CYC2</i> :CYC2 is put ahead 15 <i>CPb</i> :CPB is put ahead 16 <i>db</i> :DB is put ahead 17 <i>Addr</i> :ADDR is put ahead 18 <i>ALHY</i> :ALHY is put ahead	2
SEL2	Select 2'nd parameter for user menu	Same as SEL1	3
SEL3	Select 3'rd parameter for user menu	Same as SEL1	4
SEL4	Select 4'th parameter for user menu	Same as SEL1	6
SEL5	Select 5'th parameter for user menu	Same as SEL1	7
SEL6	Select 6'th parameter for user menu	Same as SEL1	8
SEL7	Select 7'th parameter for user menu	Same as SEL1	10
SEL8	Select 8'th parameter for user menu	Same as SEL1	17

 Dangerous voltages capable of causing death are sometimes present in this instrument. Before installation or beginning any troubleshooting procedures the power to all equipment must be switched off and isolated. Units suspected of being faulty must be disconnected and removed to a properly equipped workshop for testing and repair. Component replacement and internal adjustments must be made by a qualified maintenance person only.

 To minimize the possibility of fire or shock hazards, do not expose this instrument to rain or excessive moisture.

 Do not use this instrument in areas under hazardous conditions such as excessive shock, vibration, dirt, moisture, corrosive gases or oil. The ambient temperature of the areas should not exceed the maximum rating specified in Chapter 5.

Upon receipt of the shipment remove the control from the carton and inspect for any shipping damage. If any damage have occurred, report and claim with the shipping carrier. Write down the model number, serial number, and date code for future reference when corresponding with our service team. The serial number (S/N) and date code (D/C) are labeled on the box and the housing of control.

Make panel cutout to dimension shown in Figure 2.1.

Take both mounting clamps off and insert the control into panel cutout. Re-install the mounting clamps. Gently tighten the screws in the clamp till the controller front panels is fits snugly in the cutout.

Figure 2.1 Mounting Dimensions

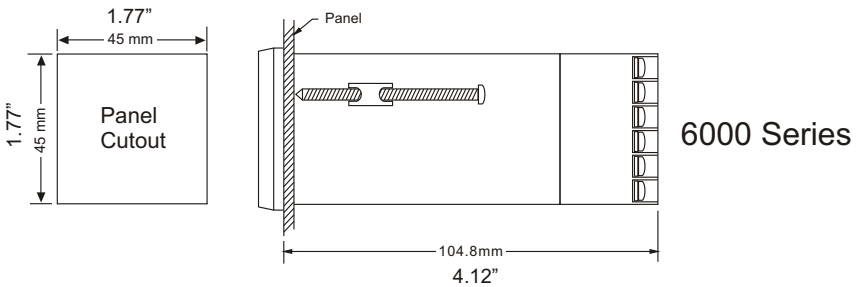
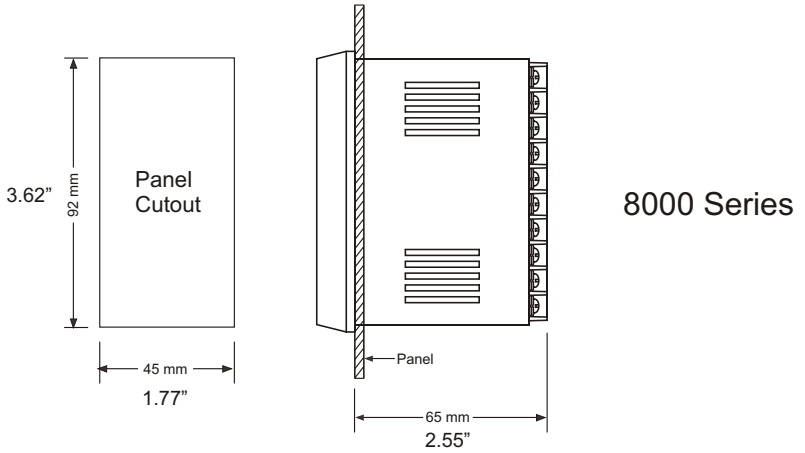
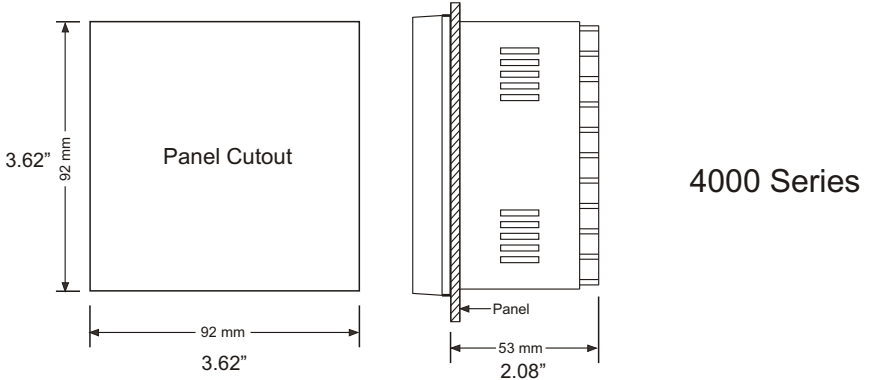

2 - 3 Wiring Precautions

- * Before wiring, verify the label for correct model number and options.
- * Care must be taken to ensure that maximum voltage rating specified on the label are not exceeded.
- * It is recommended that power of these units to be protected by fuses or circuit breakers rated at the minimum value possible.
- * All units should be installed inside a suitably grounded metal enclosure to prevent electrical shock. Installation should be performed under the supervision of a qualified electrician.
- * All wiring must conform to appropriate standards of good practice and local codes and regulations. Wiring must be suitable for voltage, current, and temperature rating of the system.
- * Beware not to over-tighten the terminal screws.
- * Unused control terminals should not be used as jumper points as they may be internally connected, causing damage to the unit.
- * Verify that the ratings of the output devices and the inputs as specified in Chapter 5 are not exceeded.

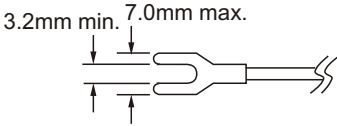

Figure 2.2
Lead Termination for
4000 Series & 8000 Series

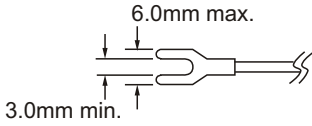

Figure 2.3
Lead Termination
for **6000 Series**

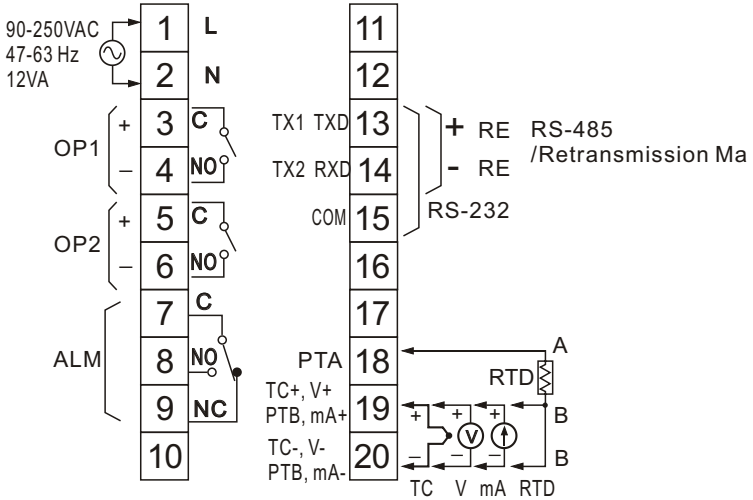

Figure 2.4
Rear Terminal Connection
for **4000 Series & 8000 Series**

PV Retrans + -
 RS-232: TXD RXD COM
 RS-485: TX1 TX2

13	14	15
----	----	----

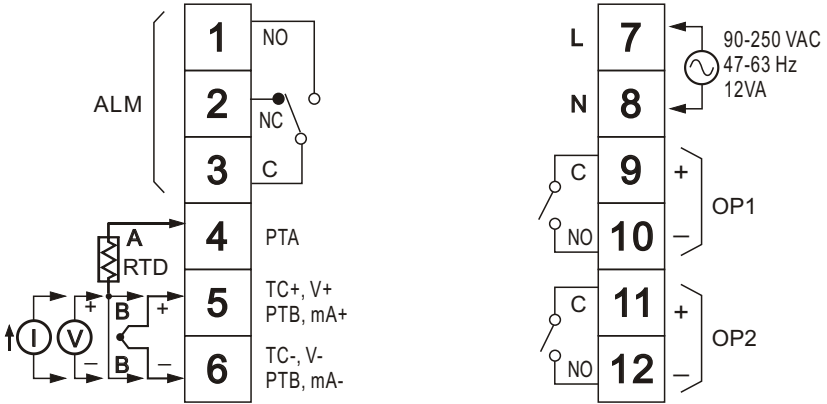

Figure 2.6
 Rear Terminal Connection for **6000 Series**

The controller is supplied to operate at 11-26 VAC / VDC or 90-250 VAC. Check that the installation voltage corresponds with the power rating indicated on the product label before connecting power to the controller.

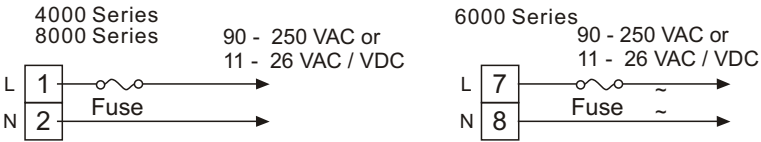

Figure 2.7 Power Supply Connections



This equipment is designed for installation in an enclosure which provides adequate protection against electric shock. The enclosure must be connected to earth ground.

Local requirements regarding electrical installation should be rigidly observed. Consideration should be given to prevent unauthorized access to the power terminals.

Proper sensor installation can eliminate many problems in a control system. The probe should be placed so that it can detect any temperature change with minimal thermal lag. In a process that requires fairly constant heat output, the probe should be placed close to the heater. In a process where the heat demand is variable, the probe should be close to the work area. Some experiments with probe location are often required to find this optimum position.

In a liquid process, the addition of a stirring device will help to eliminate thermal lag.

In many air heating applications, placing more than one thermocouple in parallel will provide an average temperature reading, producing greater overall accuracy.

Proper sensor type is also a very important factor to obtain precise measurements. The sensor must have the correct temperature range to meet the process requirements. In special processes the sensor might need to have additional options such as leak-proof, anti-vibration, be un-grounded or have special sheath materials.

Standard sensor limits of error are +/-4 degrees F (+/- 2 degrees C) or 0.75% of sensed temperature (half that for special) plus drift caused by improper protection or an over-temperature occurrence. This error is far greater than controller error and cannot be corrected on the sensor except by proper selection and replacement.

2-6 Sensor Input Wiring

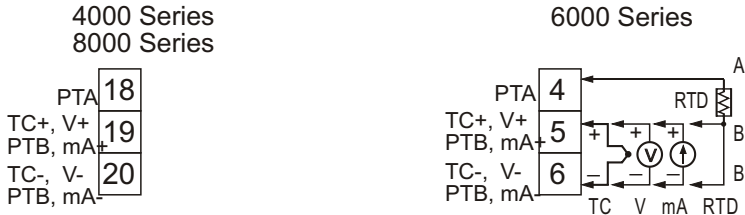

Figure 2.8 Sensor Input Wiring

2-7 Control Output 1 Wiring

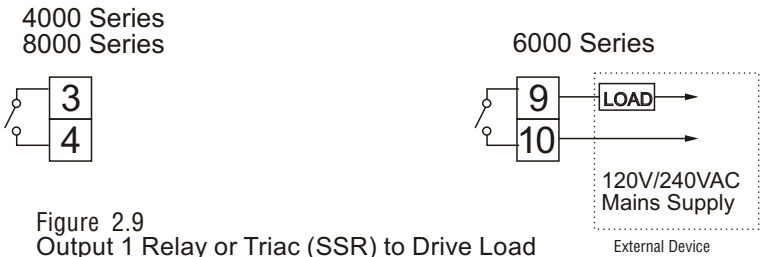

Figure 2.9 Output 1 Relay or Triac (SSR) to Drive Load

2-7 Control Output 1 Wiring (Cont'd)

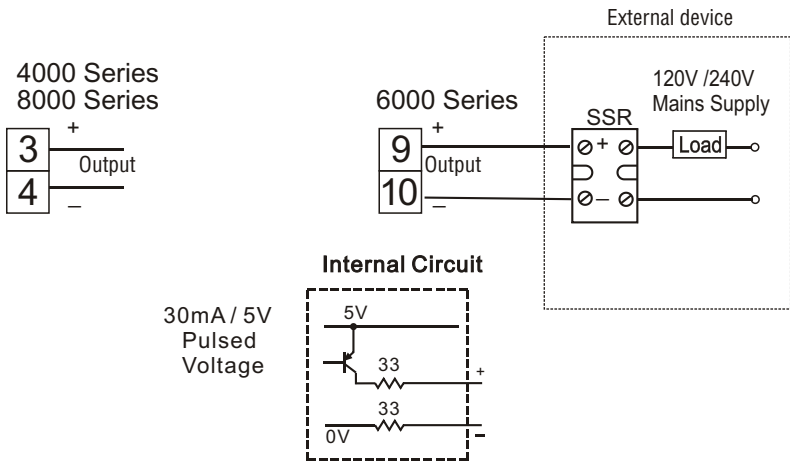

Figure 2.10 Output 1 Pulsed +5 VDC Voltage to Drive SSR

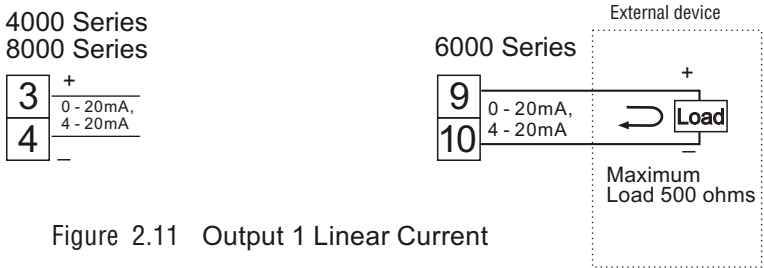

Figure 2.11 Output 1 Linear Current

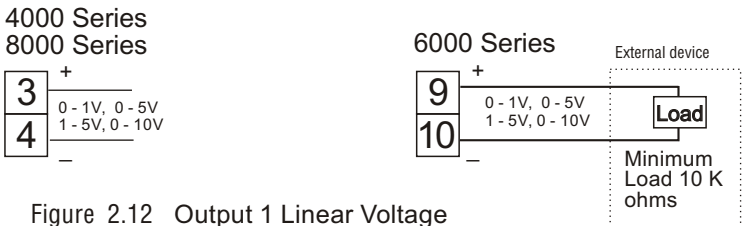

Figure 2.12 Output 1 Linear Voltage

Control Output 2 Wiring

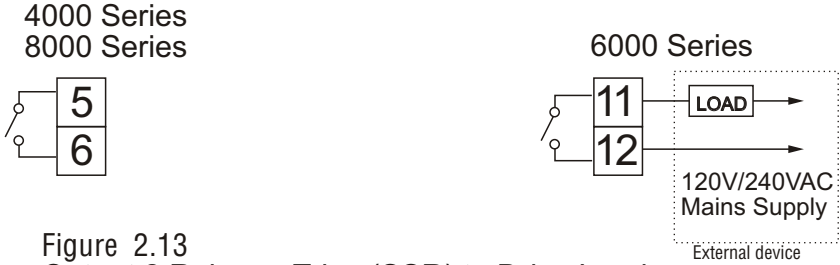

Figure 2.13 Output 2 Relay or Triac (SSR) to Drive Load

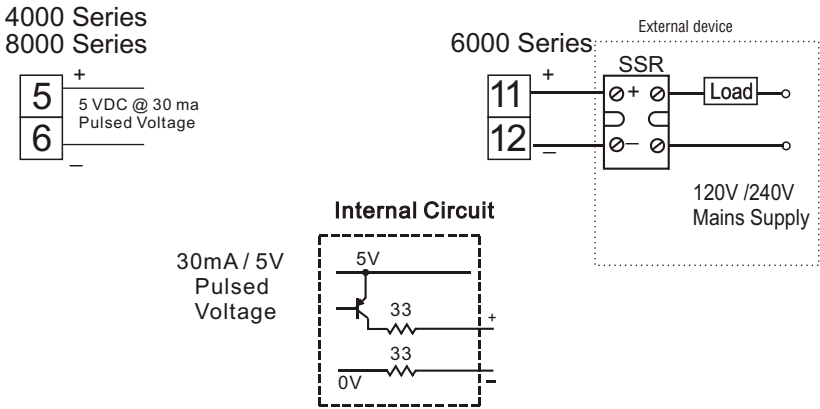

Figure 2.14 Output 2 Pulsed Voltage to Drive SSR

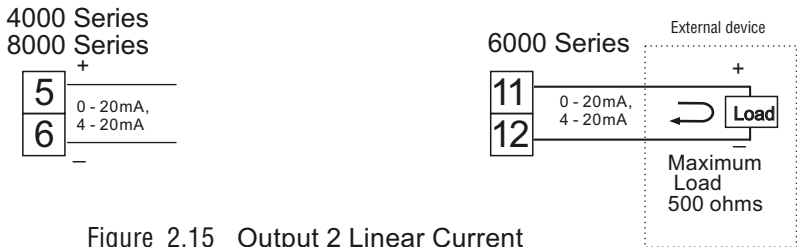

Figure 2.15 Output 2 Linear Current

Control Output 2 Wiring (Cont'd)

4000 Series.
8000 Series

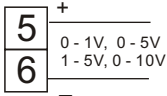
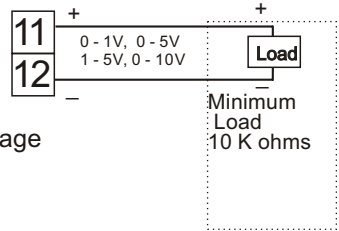

Figure 2.16 Output 2 Linear Voltage

6000 Series



2-8 Alarm Wiring

4000 Series
8000 Series

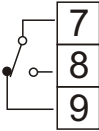
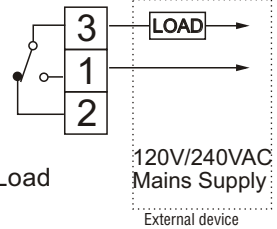

Figure 2.17 Alarm Output to Drive Load

6000 Series



2-9 Process Retransmission

4000 Series 6000 Series 8000 Series

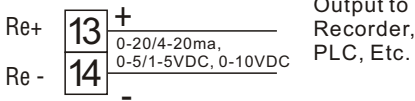

Load Resistance : 0 - 500 ohms (for current output)
10 K ohms minimum (for voltage output)

Figure 2.18
Retransmission Output Wiring

2-10 Data Communication

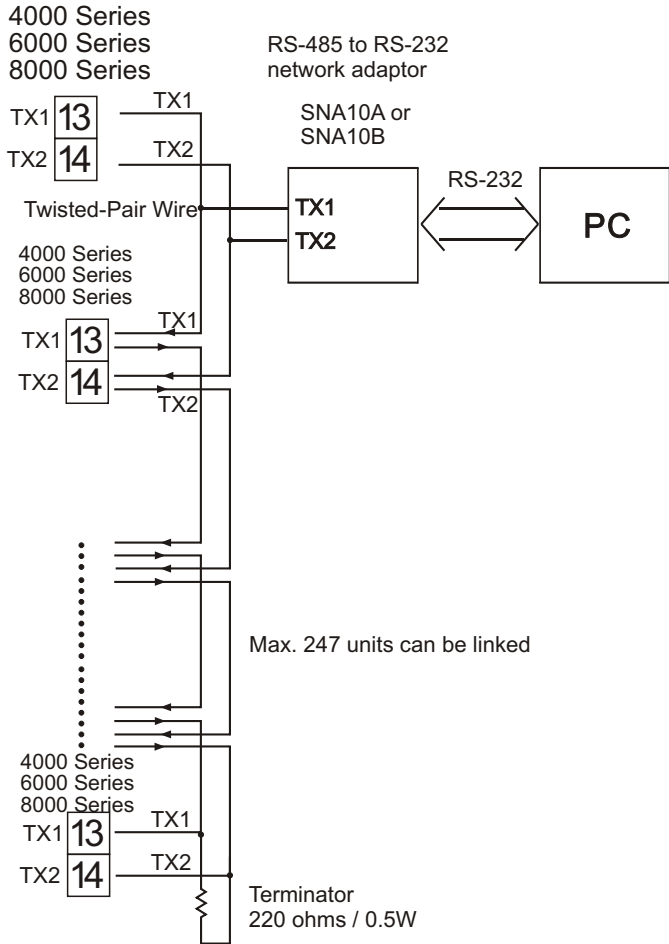

Figure 2.19 RS-485 Wiring

RS-232

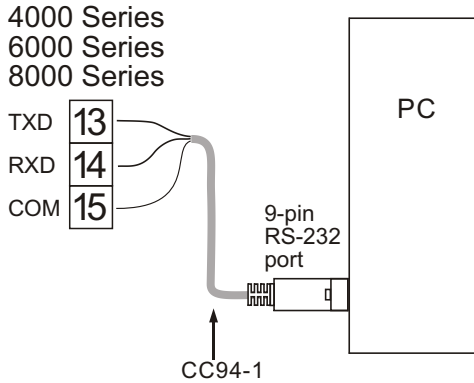

Figure 2.20
RS-232 Wiring

If you use a conventional 9-pin RS-232 cable instead of CC94-1, the cable must be modified according to the following circuit diagram.

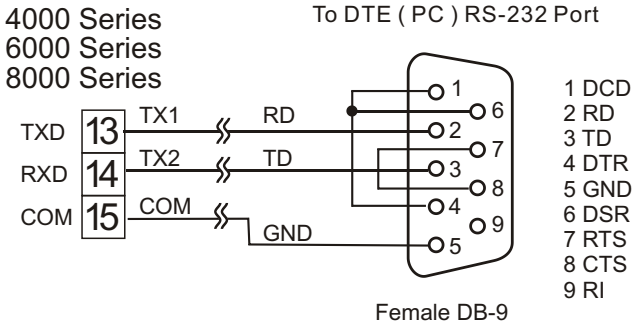



Figure 2.21
Configuration of RS-232

Chapter 3 Programming

Press  for 3 seconds and release to enter setup menu. Press  to select the desired parameter. The upper display indicates the parameter symbol, and the lower display indicates the selected value of parameter.

3-1 Lockout

There are four security levels that can be selected by using the LOCK parameter.

If **NONE** is selected for LOCK, then no parameter is locked.

If **SET** is selected for LOCK, then all setup data are locked.

If **USER** is selected for LOCK, then all setup data as well as user data (refer to **section 1-5**) except set point is locked to prevent from being changed.

If **ALL** is selected for LOCK, then all parameters are locked to prevent from being changed.

3-2 Signal Input

INPT: Selects the sensor type or signal type for signal input.

Range: (thermocouple) J, K, T, E, B, R, S, N, L
(RTD) PT.DN, PT.JS
(linear) 4-20, 0-20, 0-60, 0-1V, 0-5V, 1-5V, 0-10

UNIT: Selects the process unit

Range: C, F, PU(process unit). If the unit is neither C nor F, then selects PU.

DP: Selects the resolution of process value.

Range: (for T/C and RTD) NO.DP, 1-DP
(for linear) NO.DP, 1-DP, 2-DP, 3-DP

INLO: Selects the low scale value for the linear type input.

INHI : Selects the high scale value for the linear type input.

How to use INLO and INHI :

IA unit ordered with 4 - 20 mA is setup as INPT=4-20, then if SL specifies the input signal low (ie. 4 mA), SH specifies the input signal high (ie. 20 mA), S specifies the current input signal value, the conversion curve of the process value is shown as follows :

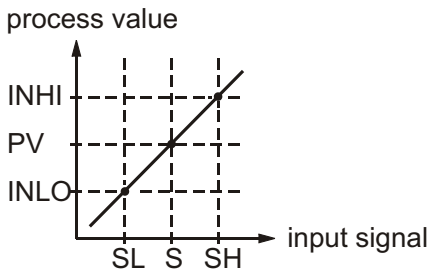

Figure 3.1
Conversion Curve for
Linear Type Process Value

Formula : $PV = INLO + (INHI - INLO) \frac{S - SL}{SH - SL}$

Example : A 4-20 mA current loop pressure transducer with range 0 - 15 kg/cm² is connected to input, then perform the following setup :

INPT = 4 - 20 INLO = 0.00
INHI = 15.00 DP = 2-DP

Of course, you may select other values for DP to alter the resolution.

3-3 Control Outputs

There are 4 kinds of control modes can be configured as shown in **Table 3.1**

Table 3.1 Heat-Cool Control Setup Value

Control Modes	OUT1	OUT2	O1HY	O2HY	CPB	DB
Heat only	REVR	×	☆	×	×	×
Cool only	DIRT	×	☆	×	×	×
Heat: PID Cool: ON-OFF	REVR	DE.HI	×	○	×	×
Heat: PID Cool: PID	REVR	COOL	×	×	○	○

× : Not Applicable

○ : Adjust to met process requirements

☆ : Required if ON-OFF control is configured

Heat Only ON-OFF Control : Select REVR for OUT1, Set PB to 0, O1HY is used to adjust dead band for ON-OFF control, The output 1 hysteresis (O1HY) is enabled in case of PB = 0 . The heat only on-off control function is shown in the following diagram :

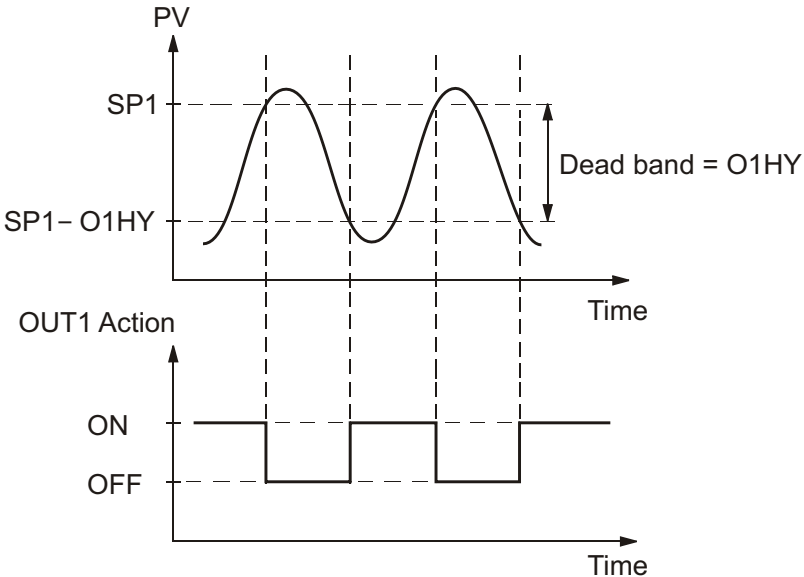

Figure 3.2 Heat Only ON-OFF Control

The ON-OFF control may introduce excessive process oscillation even if hysteresis is minimized to the smallest. If ON-OFF control is set (ie. PB = 0), TI, TD, CYC1, OFST, CYC2, CPB, DB will be hidden and have no function to the system. The auto-tuning mode and bumpless transfer will be disabled too.

Heat only P (or PD) control : Select REVR for OUT1, set TI to 0, OFST is used to adjust the control offset (manual reset). O1HY is hidden if PB is not equal to 0. OFST Function : OFST is measured by % with range 0 - 100.0 %. In the steady state (ie. process has been stabilized) if the process value is lower than the set point a definite value, say 5 LC, while 20 LC is used for PB, that is lower 25 %,

then increase OFST 25 %, and vice versa. After adjusting OFST value, the process value will be varied and eventually, coincide with set point. Using the P control (TI set to 0), the auto-tuning is disabled. Refer to section 3-12 "manual tuning" for the adjustment of PB and TD. Manual reset (adjust OFST) is not practical because the load may change from time to time and OFST would require repeated changes. Selecting the PID option will prevent this issue.

Heat only PID control : Selecting REVR for OUT1, PB and TI should not be zero. Operate auto-tuning for the new process, or set PB, TI and TD with historical values. See section 3-11 for auto-tuning operation. If the control result is still unsatisfactory, then use manual tuning to improve the control . See section 3-12 for manual tuning. The unit contains a sophisticated PID and Fuzzy algorithm to eliminate overshoot when the control is properly tuned.

Cool only control:ON-OFF control, P (PD) control and PID control can be used for cool control. Set OUT1 to DIRT (direct action). The other functions for cool only ON-OFF control, cool only P (PD) control and cool only PID control are same as descriptions for heat only control except that the output variable (and action) for the cool control is inverse to the heat control.

NOTE : The ON-OFF control may result excessive overshoot and undershoot problems in the process. The P (or PD) control will result in a deviation process value from the set point. It is recommended to use PID control for the Heat-Cool control to produce a stable and zero offset process value.

Other Setup Required : O1TY, CYC1, O2TY, CYC2, O1FT, O2FT O1TY & O2TY are set in accordance with the types of OUT1 & OUT2 installed. CYC1 & CYC2 are selected according to the output 1 type (O1TY) & output 2 type (O2TY). Generally, selects 0.5 ~ 2 sec. for CYC1, if SSRD or SSR is used for O1TY; 10 ~ 20 sec. if relay is used for O1TY, and CYC1 is ignored if linear output is used. Use similar selections for CYC2.

You can use the auto-tuning program for new processes or directly set the appropriate values for PB, TI & TD according to historical data for the repeated systems. If the control behavior is still inadequate, then use manual tuning to improve the control. See section 3-12 for manual tuning.

CPB Programming : The cooling proportional band is measured by % of PB with range 50~300. Initially set 100% for CPB and examine the cooling effect. If cooling action should be enhanced then decrease CPB, if cooling action is too strong then increase CPB. The value of CPB is related to PB and its value remains unchanged throughout the auto-tuning procedures.

Adjustment of CPB is related to the cooling media used. If air is used as the cooling media, adjust CPB to 100%. If oil is used as cooling media, adjust CPB to 125%. For water, adjust CPB to 250%.

DB Programming: Adjustment of DB is dependent on the system requirements. If more positive value of DB (greater dead band) is used, an unwanted cooling action can be avoided but an excessive overshoot over the set point will occur. If more negative value of DB (greater overlap) is used, an excessive overshoot over the set point can be minimized but an unwanted cooling action will occur. It is adjustable in the range -36.0% to 36.0 % of PB. A negative DB value shows an overlap area over which both outputs are active. A positive DB value shows a dead band area over which neither output is active.

Output 2 ON-OFF Control (Alarm function): Output 2 can also be configured as an alarm. There are 4 kinds of alarm functions that can be selected for output 2; these are: DE.HI (deviation high alarm), DE.LO (deviation low alarm), PV.HI (process high alarm) and PV.LO (process low alarm). Refer to Figure 3.3 and Figure 3.4 for the description of deviation alarm and process alarm.

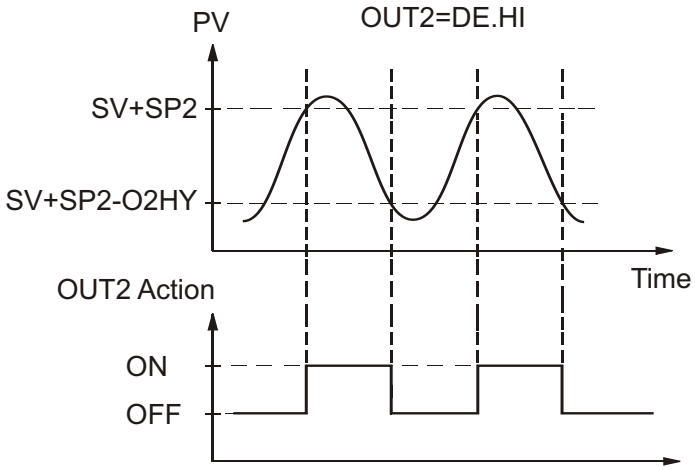

Figure 3.3 Output 2 Deviation High Alarm

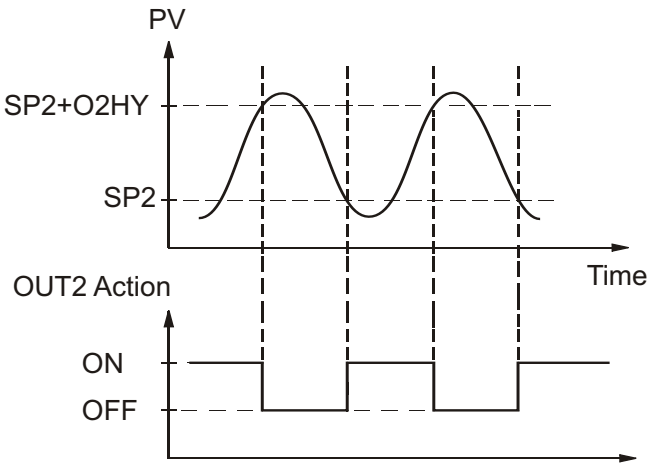

Figure 3.4 Output 2 Process Low Alarm

3-4 Alarm

The controller has one alarm output. There are 6 types of alarm functions and one dwell timer that can be selected, and four kinds of alarm modes (ALMD) that are available for each alarm function (ALFN). Besides the basic alarm output, output 2 can also be configured as an alarm. But output 2 only provides 4 kinds of alarm functions and only the normal alarm mode is available for this alarm.

A process alarm sets two absolute trigger levels. When the process is higher than SP3, a process high alarm (PV.HI) occurs, and the alarm is off as the process is lower than SP3-ALHY. When the process is lower than SP3, a process low alarm (PV.LO) occurs and the alarm is off as the process is higher than SP3+ALHY. A process alarm is independent of set point.

A deviation alarm alerts the user when the process deviates too far from set point. When the process is higher than SV+SP3, a deviation high alarm (DE.HI) occurs and the alarm is off as the process is lower than SV+SP3-ALHY. When the process is lower than SV+SP3, a deviation low alarm (DE.LO) occurs and the alarm is off as the process is higher than SV+SP3+ALHY. Trigger level of deviation alarm is moving with set point.

A deviation band alarm presets two trigger levels relative to set point. The two trigger levels are SV+SP3 and SV - SP3 for alarm. When the process is higher than (SV+SP3) or lower than (SV - SP3), a deviation band high alarm (DB.HI) occurs. When the process is within the trigger levels, a deviation band low alarm (DB.LO) occurs.

In the above descriptions SV denotes the current set point value for control which is different from SP1 as the ramp function is performed.

There are four types of alarm modes available for each alarm function, these are: Normal alarm, Latching alarm, Holding alarm and Latching/Holding alarm. They are described as follows:

Normal Alarm : ALMD = NORM

When a normal alarm is selected, the alarm output is de-energized in the non-alarm condition and energized in an alarm condition.

Latching Alarm : ALMD = LTCH

If a latching alarm is selected, once the alarm output is energized, it will remain unchanged even if the alarm condition is cleared. The latching alarm is reset when the RESET key is pressed, once the alarm condition is removed.

Holding Alarm : ALMD = HOLD

A holding alarm prevents an alarm from power up. The alarm is enabled only when the process reaches the set point value. Afterwards , the alarm performs same function as normal alarm.

Latching / Holding Alarm : ALMD = LT.HO

A latching / holding alarm performs both holding and latching function. The latching alarm is reset when the RESET key is pressed, once the alarm condition is removed.

Alarm Failure Transfer is activated as the unit enters failure mode.

Alarm will go on if ON is set for ALFT and go off if OFF is set for ALFT. The unit will enter failure mode when sensor break occurs or if the A-D converter of the unit fails.

3-5 Configure User Menu

This series has the flexibility for you to select those parameters which are most significant to your application.

These parameters are able to be put in the front of display sequence for ease of access.

SEL1~SEL8 : Selects the parameter for view and change in the user menu.

Range : LOCK, INPT, UNIT, DP, SHIF, PB, TI, TD, O1HY, CYC1, OFST, RR, O2HY, CYC2, CPB, DB, ADDR, ALHY

When using the up-down key to select the parameters, you may not obtain all of the above parameters. The number of visible parameters is dependent on the setup condition. The hidden parameters for the specific application are also deleted from the SEL selection.

Example :

OUT2 selects DE.LO PB= 100.0 SEL1 selects INPT
 SEL2 selects UNIT SEL3 selects PB SEL4 selects TI
 SEL5~SEL8 selects NONE Now, the upper display scrolling becomes :

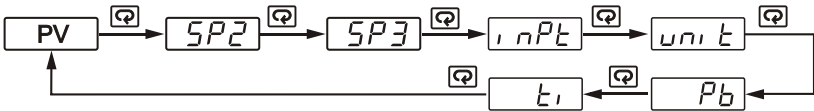

3 - 6 Ramp

The ramping function is performed during power up as well as any time the set point is changed. Choose MINR or HRR for RAMP, the unit will perform the ramping function. The ramp rate is programmed by adjusting RR. The ramping function is disabled as soon as the failure mode, the manual control mode, the auto-tuning mode or the calibration mode occurs.

Example without Dwell Timer

Select MINR for RAMP, selects C for UNIT, selects 1-DP for DP, Set RR= 10.0. SV is set to 200 C initially, and changed to 100 C after 30 minutes since power up. The starting temperature is 30 C. After power up the process is running like the curve shown below:

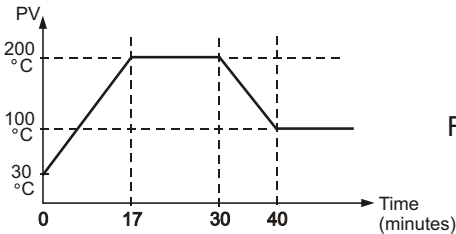

Figure 3.5 RAMP Function

Note: When the ramp function is used, the lower display will show the current ramping value. However it will revert to show the set point value as soon as the up or down key is touched for adjustment. The ramping value is initiated to process value either as power up or RR and /or set point are changed. Setting RR to zero means no ramp function at all.

3-7 Dwell Timer

The alarm output can be configured as dwell timer by selecting TIMR for ALFN . As the dwell timer is configured, the parameter SP3 is used for dwell time adjustment. The dwell time is measured in minutes ranging from 0.1 to 4553.6 minutes. Once the process reaches the set point the dwell timer starts to count down until zero (time out). The timer relay will remain unchanged until time out. The dwell timer operation is shown in the following diagram.

After time out the dwell timer will be restarted by pressing the RESET key.

The timer stops to count during the manual control mode, failure mode, calibration period and auto-tuning period.

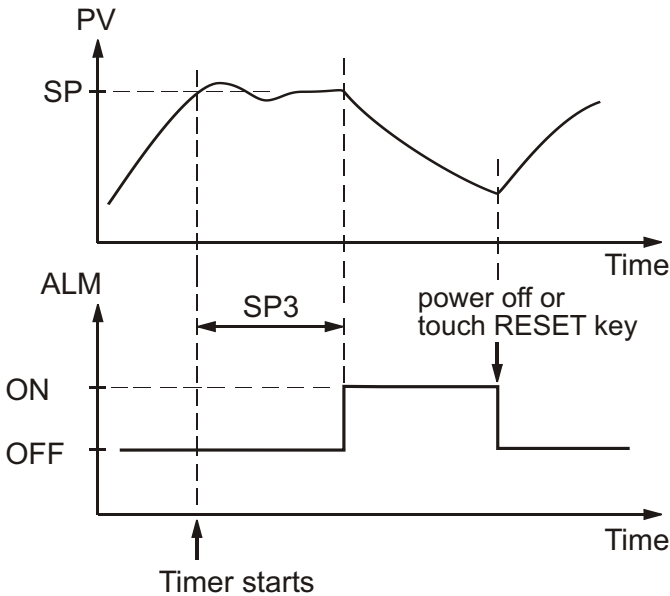

Figure 3.6 Dwell Timer Function

If alarm is configured as dwell timer, ALHY and ALMD are hidden.

3 - 8 PV Shift

In certain applications it is desirable to shift the controller display value from its actual value. This can be easily accomplished by using the PV shift function.

The SHIF function will alter PV only.

Example: If process variable is reading a value of 195 degrees and needs to match another indicator reading 200. The value of +5 can be installed in the SHIFT parameter. This will now ADD a 5 degree value to the current reading, allowing the controller to read 200 degrees. A negative value can also be used to subtract from controller current reading.

3- 9 Digital Filter

In certain applications the process value is too unstable to be read. To improve this a programmable low pass filter incorporated in the controller can be used. This is a first order filter with time constant specified by FILT parameter . The default value of FILT is 0.5 sec. before shipping. Adjust FILT to change the time constant from 0 to 60 seconds. 0 second represents no filter is applied to the input signal. The filter is characterized by the following diagram.

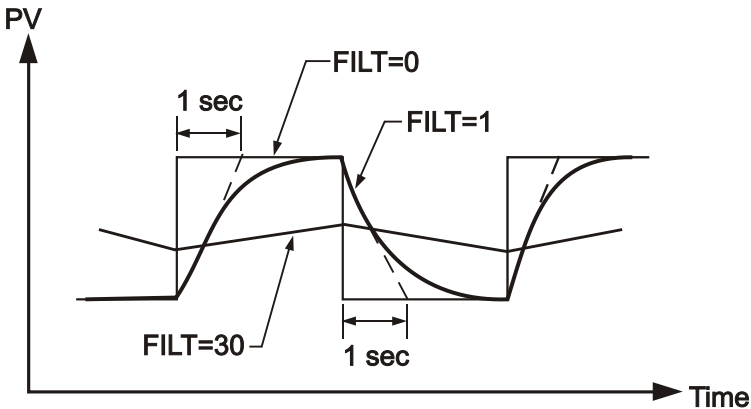

Figure 3.8 Filter Characteristics

Note

The Filter is available only for PV, and is performed for the displayed value only. The controller is designed to use unfiltered signal for control even if Filter is applied. A lagged (filtered) signal, if used for control, may produce an unstable process.

3-10 Failure Transfer

The controller will enter failure mode as one of the following conditions occurs:

1. SBER occurs due to the input sensor break or input current below 1mA if 4-20 mA is selected or input voltage below 0.25V if 1-5 V is selected .
2. ADER occurs due to the A-D converter of the controller failing.

The output 1 and output 2 will perform the failure transfer functions as the controller enters failure mode.

Output 1 Failure Transfer, if activated, will perform :

1. If output 1 is configured as proportional control ($PB \neq 0$), and BPLS is selected for O1FT, then output 1 will perform bumpless transfer. Thereafter the previous averaging value of MV1 will be used for controlling output 1.
2. If output 1 is configured as proportional control ($PB \neq 0$), and a value of 0 to 100.0 % is set for O1FT, then output 1 will perform failure transfer. Thereafter the value of O1FT will be used for controlling output 1.
3. If output 1 is configured as ON-OFF control ($PB=0$), then output 1 will transfer to off state if OFF is set for O1FT and transfer to on state if ON is set for O1FT.

Output 2 Failure Transfer, if activated, will perform :

1. If OUT2 is configured as COOL, and BPLS is selected for O2FT, then output 2 will perform bumpless transfer. Thereafter the previous averaging value of MV2 will be used for controlling output 2.
2. If OUT2 is configured as COOL, and a value of 0 to 100.0 % is set for O2FT, then output 2 will perform failure transfer. Thereafter the value of O2FT will be used for controlling output 2.
3. If OUT2 is configured as alarm function, and OFF is set for O2FT, then output 2 will transfer to off state, otherwise, output 2 will transfer to the on state if ON is set for O2FT.

Alarm Failure Transfer is activated as the controller enters failure mode. Thereafter the alarm will transfer to the ON or OFF state which is determined by the set value of ALFT.

3-11 Auto-tuning





The auto-tuning process is performed at set point. The process will oscillate around the set point during tuning process. Set the set-point to a lower value if overshooting beyond the normal process value is likely to cause damage.

The auto-tuning is applied in cases of :

- * Initial setup for a new process
- * The set point is changed substantially from the previous auto-tuning value
- * The control result is unsatisfactory *

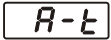
Operation :

1. The unit has been installed normally.
2. Set the correct values for the setup menu of the unit. But don't use a zero value for PB and TI , otherwise, the auto-tuning program will be disabled. The LOCK parameter should be set at NONE.
3. Set the set point to a normal operating value or a lower value if overshooting beyond the normal process value is likely to cause damage.
4. Press  and hold until  appears on the display.
5. Press  for at least 3 seconds. The AT indicator will begin to flash and the auto-tuning procedure is beginning.

NOTE :

The ramping function, if used, will be disabled once auto-tuning is proceeding.

The auto-tuning mode is disabled as soon as either failure mode or manual control mode occurs.

Procedures:

The auto-tuning can be applied either as the process is warming up (Cold Start) or as the process has been in steady state (Warm Start).

After the auto-tuning procedures are completed, the AT indicator will cease to flash and the unit revert to PID control by using its new PID values. The PID values obtained are stored in the nonvolatile memory.

ATER Auto-Tuning Error

If auto-tuning fails an ATER message will appear on the upper display in cases of :

- If PB exceeds 9000 (9000 PU, 900.0 F or 500.0 C).
- or if TI exceeds 1000 seconds.
- or if set point is changed during auto-tuning procedure.

Solutions to ATER

1. Try auto-tuning once again.
2. Don't change set point value during auto-tuning procedure.
3. Don't set zero value for PB and TI.
4. Use manual tuning instead of auto-tuning. (See section 3-12).
5. Touch RESET key to reset ATER message.

3 - 12 Manual Tuning

In some applications using auto-tuning to tune a process may be inadequate for the control requirement. You should then try manual tuning.

If the control performance using auto-tuning is still unsatisfactory, apply additional PID values show on the next page.







ADJUSTMENT SEQUENCE	SYMPTOM	SOLUTION
(1) Proportional Band (PB)	Slow Response	Decrease PB
	High overshoot or Oscillations	Increase PB
(2) Integral Time (TI)	Slow Response	Decrease TI
	Instability or Oscillations	Increase TI
(3) Derivative Time (TD)	Slow Response or Oscillations	Decrease TD
	High Overshoot	Increase TD

Table 3.2 PID Adjustment Guide

Figure 3.9 shows the effects of PID adjustment on process response.

3-13 Manual Control

Operation:

To enable manual control the LOCK parameter should be set to NONE, then press  for 4.2 seconds   (Hand Control) will appear on the display. Release key and depress  for 3 seconds then the MAN indicator will begin to flash and the lower display will show . The controller now enters the manual control mode.  indicates output control variable for output 1, and  indicates control variable for output 2. Now you can use up-down key to adjust the percentage values for the heating or cooling output.

The controller performs open loop control as long as it stays in manual control mode.

Exit Manual Control

press  key the controller will revert to its normal display mode.

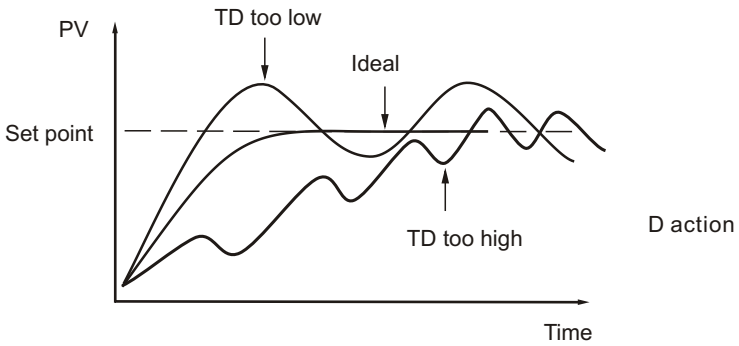
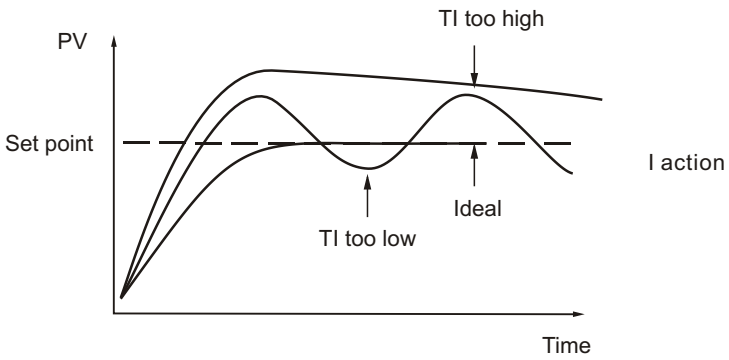
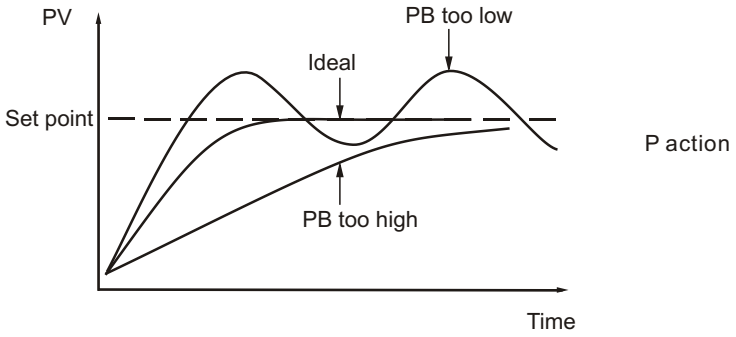

Figure 3.9 Effects of PID Adjustment

3 - 14 Data Communication

The controllers support RTU mode of Modbus protocol for data communication. Other protocols are not available for the series.

Two types of interface are available for Data Communication. These are RS-485 and RS-232 interface. Since RS-485 uses a differential architecture to drive and sense signal instead of a single ended architecture which is used for RS-232, RS-485 is less sensitive to the noise and thus suitable for a longer distance communication. RS-485 can communicate without error over 1 km distance while RS-232 is not recommended for a distance over 20 meters.

Using a PC for data communication is convenient approach. The signal is transmitted and received through the PC communication Port (generally RS-232). Since a standard PC may not support a RS-485 port, a network adaptor (such as SNA10A) will need to be used to convert RS-485 to RS-232 for a PC if RS-485 is required for data communication. Multiple RS-485 units (up to 247 units) can be connected to one RS-232 port.

Setup

Enters the setup menu.

Select RTU for COMM . Set individual address as for those units which are connected to the same port.

Set the Baud Rate (BAUD), Data Bit (DATA), Parity Bit (PARI) and Stop Bit (STOP) such that these values are accordant with PC setup conditions.

3 - 15 Process Retransmission

The controllers support a optional ma/VDC output (retransmit) of the process variable. The program parameters to scale the ma/VDC signal are RELO and REHI, respectively for low and high scale.

For example, using a 4/20 ma retransmission option to represent a temperature of 0/200 F unit would be setup as;

RELO = 0 for 4 ma equals 0 F

REHI = 200 for 20 ma equals 200 F

This output would typically go to a recorder, PLC, indicator etc.

Chapter 4 Calibration

 Do not proceed through this section unless there is a definite need to re-calibrate the controller. Otherwise, all previous calibration data will be lost. Do not attempt recalibration unless you have appropriate calibration equipment. If calibration data is lost, you will need to return the controller to your supplier who may charge you a service fee to re-calibrate the controller.

 Entering calibration mode will break the control loop. Verify that the system is acceptable to apply calibration mode.

Equipment needed before calibration:

- (1) A high accuracy calibrator (Fluke 5520A Calibrator recommended) with following functions:
 - 0 - 100 mV millivolt source with +/-0.005 % accuracy
 - 0 - 10 V voltage source with +/-0.005 % accuracy
 - 0 - 20 mA current source with +/-0.005 % accuracy
 - 0 - 300 ohm resistant source with +/-0.005 % accuracy
- (2) A test chamber providing 25 C - 50 C temperature range
- (3) A switching network (SWU16K, optional for automatic calibration)
- (4) A calibration fixture equipped with programming units (optional for automatic calibration)
- (5) A PC installed with calibration software FDC-Net and Smart Network Adaptor SNA10B (optional for automatic calibration)

The calibration procedures described in the following section are a step by step manual procedures.

Since it needs 30 minutes to warm up an unit before calibration, calibrating the unit one by one is quite inefficient. An automatic calibration system for small quantity as well as for unlimited quantity is available. Consult factory.

Manual Calibration Procedures

- * Perform step 1 to enter calibration mode.

Step 1. Set the Lock parameter to the unlocked condition (LOCK=NONE).

Press and hold the scroll key until **CLL** appears on the display, then release the scroll key.

Press the scroll key for 2 seconds then release, the display will show **AdLo** and the unit enters calibration mode .

- * Perform step 2 to calibrate Zero of A to D converter and step 3 to calibrate gain of A to D converter.

Step 2. Short the thermocouple input terminals, then press the scroll key for at least 3 seconds. The display will blink a moment and a new value is obtained. Otherwise, if the display didn't blink or if the obtained value is equal to -199.9 or 199.9, then the calibration failed.

Step 3. Press scroll key until the display shows **AdHi** . Send a 60 mV signal to the thermocouple input terminals in correct polarity . Press scroll key for at least 3 seconds . The display will blink a moment and a new value is obtained . Otherwise , if the display didn't blink or if the obtained value is equal to -199.9 or 199.9, then the calibration failed.

- * Perform both steps 4 and 5 to calibrate RTD function (if required) for input .

Step 4. Press scroll key until the display shows rtDL . Send a 100 ohms signal to the RTD input terminals according to the connection shown below:



Figure 4.1 RTD Calibration

Press scroll key for at least 3 seconds . The display will blink a moment, otherwise the calibration failed.

Step 5. Press scroll key and the display will show rtDH . Change the ohm's value to 300 ohms .Press scroll key for at least 3 seconds. The display will blink a moment and two values are obtained for RTDH and RTDL (step 4). Otherwise, if the display didn't blink or if any value obtained for RTDH and RTDL is equal to -199.9 or 199.9 , then the calibration failed.

- * Perform step 6 to calibrate offset of cold junction compensation, if required.

Step 6. Setup the equipments according to the following diagram for calibrating the cold junction compensation.
Note that a "K" type thermocouple must be used.

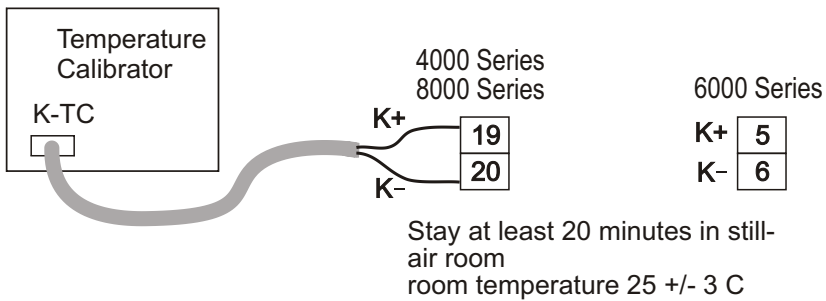

Figure 4.2
Cold Junction Calibration Setup

The temperature calibrator is configured as K type thermocouple output with internal compensation. Send a 0.00 C signal to the unit under calibration.

The unit under calibration is powered in a still-air room with temperature 25 +/-3 C. Stay at least 20 minutes for warming up. Perform step 1 stated above, then press scroll key until the display shows

--	--	--	--

. Press up/down key to obtain 40.00.

Press scroll key for at least 3 seconds. The display will blink a moment and a new value is obtained. Otherwise, if the display didn't blink or if the obtained value is equal to -5.00 or 40.00, then the calibration failed.

* Perform step 7 to calibrate gain of cold junction compensation if required.

Step 7. Setup the equipments same as step 6. The unit under calibration is powered in a still-air room with temperature 50 +/-3 C. Stay at least 20 minutes for warming up. The calibrator source is set at 0.00 C with internal compensation mode.

Perform step 1 stated above , then press scroll key until the display shows $\boxed{C JH_1}$. Press the scroll key for at least 3 seconds. The display will blink a moment and a new value is obtained. Otherwise , if the display didn't blink or if the obtained value is equal to -199.9 or 199.9, then the calibration failed.

This setup is performed in a high temperature chamber, hence it is recommended to use a computer to perform the procedures.

* Input modification and recalibration procedures for a linear voltage or a linear current input:

1. Remove R60(3.3K) and install two 1/4 W resistors RA and RB on the control board with the recommended values specified in the following table.

The low temperature coefficient resistors should be used for RA and RB.

Input Function	RA	RB	R60
T/C, RTD, 0~60mV	X	X	3.3K
0 ~ 1 V	61.9K	3.92K	X
0 ~ 5V, 1 ~ 5V	324K	3.92K	X
0 ~ 10 V	649K	3.92K	X
0~20mA, 4~20mA	39 _{ohm}	3.01 _{ohm}	X

2. Perform Step 1 and Step 2 to calibrate the linear input zero.

3. Perform Step 3 but send a span signal to the input terminals instead of 60mV. The span signal is 1V for 0~1V input, 5V for 0~5V or 1~5V input, 10V for 0~10V input and 20mA for 0~20mA or 4~20mA input.

* Final step

Step 8. Set the LOCK value to your desired function.

Chapter 5 Specifications

Power

90 - 250 VAC, 47 - 63 Hz, 12VA, 5W maximum

11 - 26 VAC / VDC, 12VA, 5W maximum

Input

Resolution:	18 bits
Sampling Rate:	5 times / second
Maximum Rating:	-2 VDC minimum, 12 VDC maximum. (1 minute for mA input)
Temperature Effect: except	+/-1.5uV/ C for all inputs mA input. +/-3.0uV/ C for mA input
Lead Resistance Effect:	T/C: 0.2uV/ohm 3-wire RTD: 2.6 C/ohm of resistance difference of two leads. 2-wire RTD: 2.6 C/ohm of resistance sum of two leads
Burn-out Current:	200 mA
Common Mode Rej:	120dB
Normal Mode Rej:	55dB

Sensor Break Detection:

Sensor open for TC, RTD and mV inputs,

Sensor short for RTD input

below 1 mA for 4-20 mA input,

below 0.25V for 1 - 5 V input, unavailable for
other inputs.

Sensor Break Responding Time:

Within 4 seconds for TC, RTD and mV inputs. 0.1 second for
4-20 mA and 1 - 5 V inputs.

Characteristics:

Type	Range	Accuracy @ 25 °C	Input Impedance
J	-120 °C 1000 °C (-184 °F 1832 °F)	+/- 2 °C	2.2 MΩ
K	-200 °C 1370 °C (-328 °F 2498 °F)	+/- 2°C	2.2 MΩ
T	-250 °C 400 °C (-418 °F 752 °F)	+/- 2°C	2.2 MΩ
E	-100 °C 900 °C (-148 °F 1652 °F)	+/- 2°C	2.2 MΩ
B	0 °C- 1800 °C (32 °F -3272 °F)	+/- 2°C	2.2 MΩ
R	0 °C- 1767.8 °C (32 °F- 3214 °F)	+/- 2°C	2.2 MΩ
S	0 °C- 1767.8 °C (32 °F- 3214 °F)	+/- 2°C	2.2 MΩ
N	-250 °C 1300 °C (-418 °F 2372 °F)	+/- 2°C	2.2 MΩ
L	-200 °C 900 °C (-328 °F 1652 °F)	+/- 2°C	2.2 MΩ
PT100 (DIN)	-210 °C 700 °C (-346 °F 1292 °F)	+/-0.4 °C	1.3 KΩ
PT100 (JIS)	-200 °C 600 °C (-328 °F 1112 °F)	+/-0.4 °C	1.3 KΩ
mV	-8mV 70mV	+/-0.05 %	2.2 MΩ
mA	-3mA 27mA	+/-0.05 %	70.5Ω
V	-1.3V 11.5V	+/-0.05 %	650 KΩ

Output 1 / Output 2

Relay Rating : 2A/240 VAC, life cycles 200,000
for resistive load.

Pulsed Voltage : Source Voltage 5V,
current limiting resistance 66.

Linear Output Characteristics

Ω

Type	Zero Tolerance	Span Tolerance	Load Capacity
4-20 mA	3.8-4 mA	20-21 mA	500 Ω max.
0-20 mA	0 mA	20-21 mA	500 Ω max.
0 ~ 5 V	0 V	5 ~ 5.25 V	10 K Ω min.
1 ~ 5 V	0.95 ~ 1 V	5 ~ 5.25 V	10 K Ω min.
0 ~ 10 V	0 V	10 ~10.5 V	10 K Ω min.

Linear Output

Resolution: 15Bits
Output Regulation : 0.02 % for full load change
Output Settling Time : 0.1 sec. (stable to 99.9 %)
Isolation Breakdown Voltage : 1000 VAC
Temperature Effect: +/-0.01 % of SPAN / LC

Triac (SSR) Output

Rating: 1A / 240 VAC
Inrush Current: 20A for 1 cycle
Min. Load Current: 50 mA rms
Max. Off-state Leakage: 3 mA rms
Max. On-state Voltage: 1.5 V rms
Insulation Resistance: 1000 Mohms min. at 500 VDC
Dielectric Strength: 2500 VAC for 1 minute

DC Voltage Supply Characteristics (Installed at Output 2)

Type	Tolerance	Max. Output Current	Ripple Voltage	Isolation Barrier
20 V	+/-0.5 V	25 mA	0.2 Vp-p	500 VAC
12 V	+/-0.3 V	40 mA	0.1 Vp-p	500 VAC
5 V	+/-0.15 V	80 mA	0.05 Vp-p	500 VAC

Alarm

Alarm Relay : Form C Rating
2A/240VAC, 200,000 cycles for resistive load.

Alarm Functions : Dwell timer, PV High / Low Alarm,
Deviation High / Low Alarm,
Deviation Band High / Low Alarm

Alarm Mode : Normal, Latching, Hold, Latching / Hold.

Dwell Timer : 0.1 - 4553.6 minutes

Data Communications

Interface: RS-232 (1 unit), RS-485 (up to 247 units)

Protocol: Modbus Protocol RTU mode

Address: 1 - 247

Baud Rate: 2.4 ~ 38.4 Kbits/sec

Data Bits: 7 or 8 bits

Parity Bit: None, Even or Odd

Stop Bit: 1 or 2 bits

Comm Buffer: 160 bytes

Analog Retransmission

Functions: Process Variable

Output Signal: 4-20 mA, 0-20 mA, 0 - 5V, 1 - 5V, 0 - 10V

Resolution : 15 bits

Accuracy : +/-0.05 % of span +/-0.0025 %/ C

Load Resistance : 0 - 500 ohms (for current output)
10 K ohms minimum (for voltage output)

Regulation: 0.01 % for full load change

Settling Time: 0.1 sec. (stable to 99.9 %)

Breakdown Volts: 1000 VAC min.

Linearity Error : +/-0.005 % of span

Temp Effect: +/-0.0025 % of span / C

Saturation Low : 0 mA (or 0V)

Saturation High : 22.2 mA (or 5.55V, 11.1V min.)

Output Range : 0-22.2mA(0-20mA or 4-20mA)
0-5.55V (0 - 5V, 1 - 5V)
0 - 11.1 V (0 - 10V)

User Interface

Display: Dual 4-digit LED Displays
Keypad: 4 keys
Programming Port: For automatic setup, calibration and testing
Communication Port : Connection to PC for supervisory control

Control Mode

Output 1: Reverse (heating) or direct (cooling) action
Output 2: PID cooling control, cooling P band 50~300% of PB, dead band -36.0 ~ 36.0 % of PB
ON-OFF: 0.1 - 90.0 (F) hysteresis control (P band = 0)
P or PD: 0 - 100.0 % offset adjustment
PID: Fuzzy logic modified
Proportional band 0.1 ~ 900.0 F.
Integral time 0 - 1000 seconds
Derivative time 0 - 360.0 seconds
Cycle Time: 0.1 - 90.0 seconds
Manual Control: Heat (MV1) and Cool (MV2)
Auto-tuning: Cold start and warm start
Failure Mode: Auto-transfer to manual mode while
Ramping Control: sensor break or A-D converter damage
0 - 900.0 F/minute or
0 - 900.0 F/hour ramp rate

Digital Filter

Function: First order
Time Constant: 0, 0.2, 0.5, 1, 2, 5, 10, 20, 30, 60 seconds programmable

Environmental & Physical

Operating Temperature:	-10 C to 50 C
Storage Temperature:	-40 C to 60 C
Humidity:	0 to 90 % RH (non-condensing)
Insulation Resistance:	20 Mohms min. (at 500 VDC)
Dielectric Strength :	2000 VAC, 50/60 Hz for 1 minute
Vibration Resistance:	10 - 55 Hz, 10 m/s for 2 hours
Shock Resistance:	200 m/s (20 g)
Moldings:	Flame retardant polycarbonate
Dimensions:	
4000 Series:	96mm(W) X 96mm(H) X 65mm(D), 53 mm depth behind panel
6000 Series:	48mm(W) X 48mm(H) X 116mm(D), 105 mm depth behind panel
8000 Series:	48mm(W) X 96mm(H) X 80mm(D), 65 mm depth behind panel
Weight :	4000 Series: 250 grams 6000 Series: 150 grams 8000 Series: 210 grams

Agency Approvals

UL Pending
CSA Pending

Protective Class:

IP65 for panel with additional option
IP50 for panel without additional option
Ip20 for terminals and housing with protective cover.

EMC: EN61326

Table A.1 Error Codes and Corrective Actions

Error Code	Display Symbol	Error Description	Corrective Action
4	<i>Er04</i>	Illegal setup values have been used: Before COOL is used for OUT2, DIRT (cooling action) has already been used for OUT1, or PID mode is not used for OUT1 (that is PB = 0, and / or TI = 0)	Check and correct setup values of OUT2, PB, TI and OUT1. IF OUT2 is required for cooling control, the control should use PID mode (PB = 0, TI = 0) and OUT1 should use reverse mode (heating action) , otherwise, don't use OUT2 for cooling control.
10	<i>Er 10</i>	Communication error: bad function code	Correct the communication software to meet the protocol requirements.
11	<i>Er 11</i>	Communication error: register address out of range	Don't issue an over-range register address to the slave.
14	<i>Er 14</i>	Communication error: attempt to write a read-only data or a protected data	Don't write a read-only data or a protected data to the slave.
15	<i>Er 15</i>	Communication error: write a value which is out of range to a register	Don't write an over-range data to the slave register.
26	<i>AtEr</i>	Fail to perform auto-tuning function	<ol style="list-style-type: none"> 1.The PID values obtained after auto-tuning procedure are out of range. Retry auto-tuning. 2.Don't change set point value during auto-tuning procedure. 3.Use manual tuning instead of auto-tuning. 4. Don't set a zero value for PB. 5. Don't set a zero value for TI. 6. Touch RESET key
29	<i>EEPE</i>	EEPROM can't be written correctly	Return to factory for repair.
30	<i>CJEr</i>	Cold junction compensation for thermocouple malfunction	Return to factory for repair.
39	<i>SbEr</i>	Input sensor break, or input current below 1 mA if 4-20 mA is selected, or input voltage below 0.25V if 1 - 5V is selected	Replace input sensor.
40	<i>AdEr</i>	A to D converter or related component(s) malfunction	Return to factory for repair.

Warranty

Proheat Inc. makes no warranty or representations of any sort regarding the fitness for use, merchantability, fitness for a particular purpose or the application of its products by the purchaser. The selection, application or use of Proheat Inc. products is the purchaser's responsibility.

Proheat Inc. controls are warranted to be free from functional defects in material and workmanship for **TWO YEARS** after delivery to the first purchaser.

Proheat Inc.'s sole responsibility under the warranty, at Proheat Inc.'s option, is limited to replacement or repair, free of charge, or refund of purchase price within the warranty period specified. This warranty does not apply to damage resulting from transportation, alteration, misuse or abuse.

No claims will be allowed for any damages or losses, whether direct, indirect, incidental, special or consequential. Specifications are subject to change without notice. In addition, Proheat Inc. reserves the right to make changes without notification to purchaser to materials or processing that do not affect compliance with any applicable specifications.

There are no expressed or implied warranties extending beyond the warranty herein.

RETURN MATERIAL AUTHORIZATION:

Please contact Proheat Inc. for Return Material Authorization number prior to any returns.

Proheat Inc.
117 East Adam Street
LaGrange, KY 40031
Main Office Phone: 502-222-1402
Fax: 502-222-0714
Technical Support
Phone: 502-222-1402
www.proheatinc.com
E-mail: sales@proheat.net