

Introduction to Cast-In Heaters 3-2
Design Specifications 3-3
Liquid Cooled Cast-In Heaters..... 3-6
Air Cooled Cast-In Heaters 3-20
Arctic-Cast™
Forced Air Cooled Heaters..... 3-28
Checkmate™
Forced Air Cooled Heaters..... 3-36

“L” Shaped Cast-In Heaters 3-38
Cast-In Platen Heaters 3-42
Cast-In Ring Heaters..... 3-46
Cross Head Die Heaters..... 3-47
Special Cast-In Heater Shapes..... 3-48
Cast-In Heaters for Commercial,
Industrial and Scientific Applications 3-50
Installation Recommendations 3-54

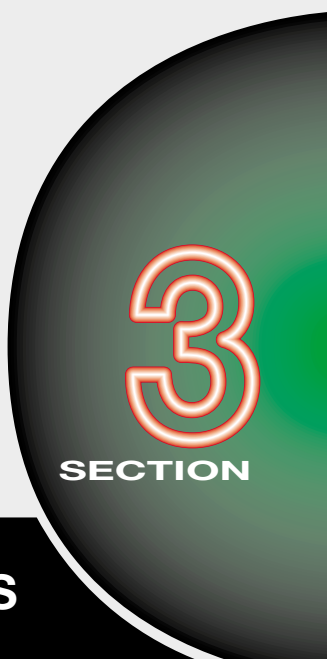

CAST-IN HEATERS



TEMPCO

offers the

largest

selection

in Quality

Cast-In Heaters



SINGLE SOURCE ADVANTAGE FROM BEGINNING TO END

Tempco has set industry standards as the leading manufacturer of Aluminum, Brass and Bronze Cast-In Heaters in a variety of standard designs and styles.

However, we realize not every Cast-In Heater application can be solved by one of our standard products. Our solutions help our customers and create new opportunities for Tempco. It is our engineering talents and vast application knowledge that provides a winning combination for solving specific application problems with the right Cast-In Heater.

The design engineering and manufacturing of Tempco Cast-In Heaters is done under one roof—administered by a team of experienced professionals with a vast knowledge in product design and proven foundry expertise, producing the best quality Cast-In Heater money can buy.

Computer designed Tubular Heaters manufactured under our rigid quality control standards are the heat source for the Cast-In Heater. They can be formed into endless configurations to accommodate any practical Cast-In Heater shape.

A full-service in-house **Wood Pattern Shop** builds, modifies and maintains patterns.

Tempco's modern **Non-Ferrous Foundry** produces Permanent Mold Castings and Sand Castings, using the No-Bake sand process. Our casting team has years of practical and educational experience essential for producing quality castings with cosmetically appealing surface finishes.

Tempco's modern **Machine Shop**, fully equipped with CNC Mills and Turning Machines, provides precision machining, assuring proper fits as well as accommodating vent cutouts, clearance holes and unique geometric shapes.

*Consult us with your requirements.
No one can do it better than
Tempco — Let us prove it*

Cast-In Heaters are produced in-house by a team of experts for unparalleled quality!

SATISFACTION GUARANTEED!

Plastic Processing

Our Cast-In Band Heaters have proven to be the most effective method for heating and cooling the barrels of extruders used in plastics processing.

Tempco offers Cast-In Band Heaters with liquid and/or air cooling. Liquid cooling incorporates tubing cast in as part of the heater assembly, allowing water or heat transfer solutions to remove the heat. Air cooling uses fins cast to the O. D. surface of the band heater; blowers and specially designed shrouds aid in heat removal.

Aluminum is the predominant alloy used for the Cast-In Heater. Copper based alloys (Bronze and Brass) are used when the required operating temperatures exceed the maximum for aluminum. Bronze or brass is recommended for heated platens in molding presses as they can withstand a greater force per square inch than aluminum.

Typical Applications

- Extruders**
- Laminating Equipment**
- Injection Molding**
- Vacuum Forming**
- Extrusion Die Heads**
- Compression Molding**
- Blow Molding**
- Heat Sealers**
- Food Processing**
- Silk Screening**
- Laboratory Equipment**
- Tire Making Machines**

Many Other Applications

Cast-In Heaters are used in numerous industries including food processing and packaging. Turn to pages 3-53 through 3-53 for some examples showing the flexibility of Cast-In Heaters.

“Our capabilities are limited only by your imagination!”



Casting Process

Permanent Molds: For large quantity runs, this process uses steel or cast iron molds and yields a superior finish and enhanced cosmetic value.

No-Bake Sand Molds: For small quantity runs, this process requires wooden patterns. This is an economical, fast means of manufacturing tooling for lower volume casting requirements and for making prototypes.

Special Features

The following special features can be incorporated into Cast-In Heater designs. Specify exact dimensions and locations.

- * Holes
- * Cutouts
- * Taper Angles
- * Slots
- * Chamfers
- * Thermowells
- * Electroless Nickel Plating
- * Teflon® Coating
- * Standoffs
- * Mounting Studs
- * Ground Studs

Cast Alloys

Alloy	Maximum Surface Temperature
Aluminum 319 (Standard)	700°F (375°C)
Aluminum 356 (Optional)	750°F (399°C)
Aluminum 443 (Optional)	850°F (454°C)
Aluminum 355 (Optional)	850°F (454°C)
Brass	1200°F (649°C)
Aluminum Bronze	1350°F (732°C)

Cooling Tube Sizes and Materials

Stainless Steel — (Standard) ¼" O.D. × .020 wall
Stainless Steel — (Standard) ⅜" O.D. × .035 wall
Stainless Steel — (Standard) ½" O.D. × .049 wall
Stainless Steel — (Optional) ⅝" O.D. × .049 wall
Incoloy® — (Optional) ½" O.D. × .049 wall

Clamping Styles

Strap Clamping: 20 Gauge Type 430 Stainless Steel Straps with ¼"-20 Bolts and Barrel Nuts—
¾", and 1¼" wide standard

Bolt Clamping: Specify Fastener Requirements

Dimensional

	Cylindrical	Platen
Minimum Inside Diameter	1"	—
Maximum Inside Diameter	48"	—
Minimum Width	2½"	1½"
Maximum Width	36"	60"
Minimum Length	2"	4"
Maximum Length	36"	72"
Finish	125 RMS Standard	
Gap	¼" top and bottom or to customer specification	

Electrical

Tubular Heater Diameter	.260"	.315"	.375"	.430"	.475"
Maximum Volts	240	277	480	550	550
Maximum Amps per element	15	30	40	40	40

Three Phase available depending on Casting Size

Resistance Tolerance: +10%, -5%

Wattage Tolerance: +5%, -10%

Maximum Watt Density Aluminum Alloy—35 W/in² on the element

Maximum Watt Density Bronze or Brass—45 W/in² on the element

Thickness for Cast-In Heaters (inches)

Casting Thickness	Available Element Diameter Heat Only	Maximum Available Cooling Tube Diameter	Maximum Element and Cooling Tube Combination
		Cool Only	Heat and Cool
⅝"	.260	¼"	—
¾"	.260, .315, .430	⅜"	—
1"	.260, .315, .430	⅝"	.260 and ⅜"
1⅜"	.315, .430	½"	.315 and ½"
1½"	.315, .430	½"	.430 and ½"
1⅝"	.315, .430, .475	½"	.430 and ½"
1¾"	.315, .430, .475	½"	.430 and ½"
Finned Casting			
¾"	.260, .315	⅜"	—
1"	.260, .315, .430	½"	.260 and ⅜"
1¾"	.315, .430	½"	.430 and ½"



A full-service in-house Wood Pattern Shop builds, modifies and maintains patterns.



Why more original equipment manufacturers specify
THE FACTS

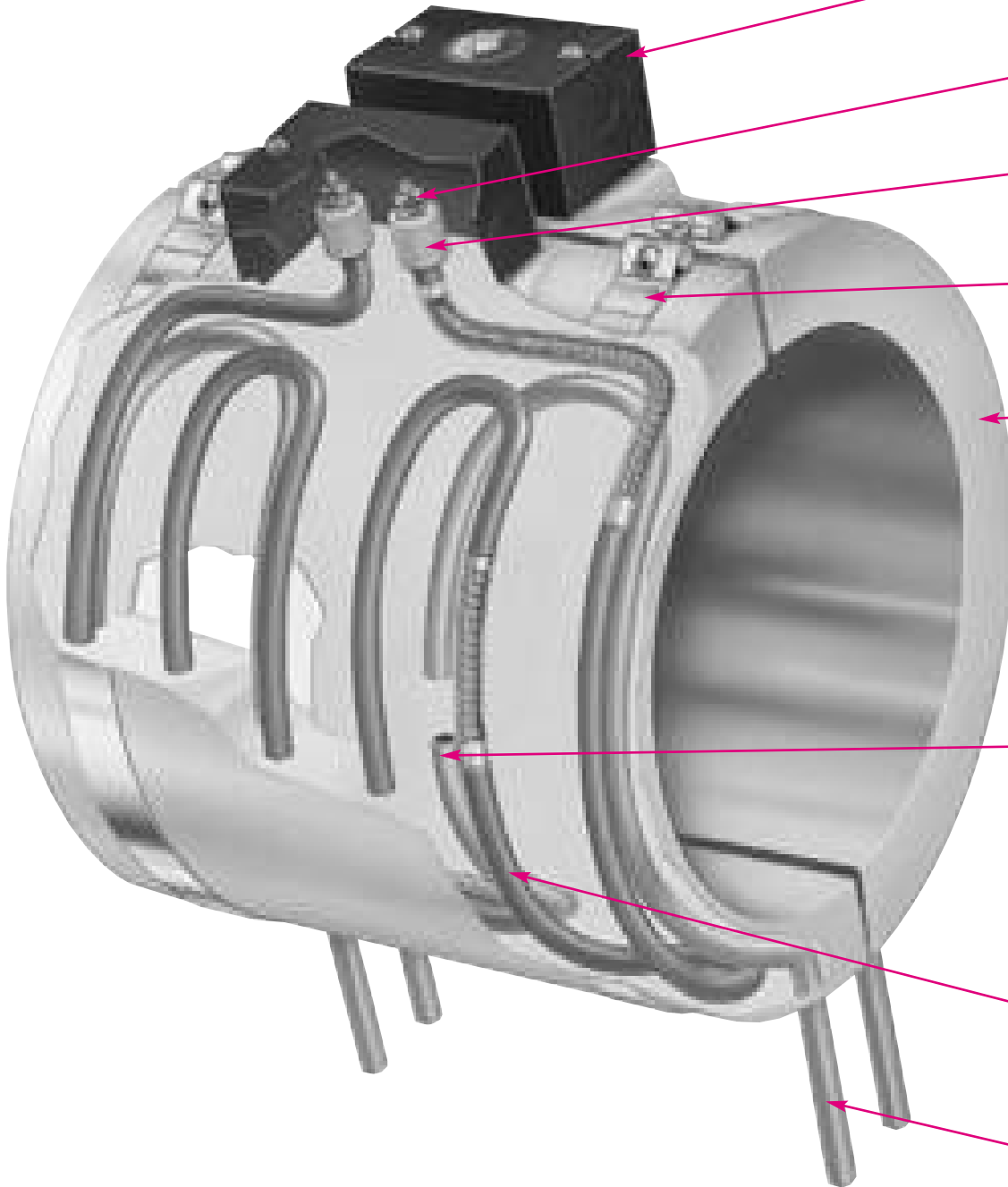



our Cast-In Heaters for their Plastics Processing Equipment

- A** General purpose steel terminal boxes provide a simple and economical way to eliminate exposure to live electrical terminals. To simplify electrical wiring, the box has two knockouts for standard $\frac{3}{8}$ " BX cable connectors. Boxes can be supplied factory prewired with high temperature lead wire protected with armor cable or wire braid. Other boxes are available to accommodate your requirements. See pages 3-12 and 3-13.
- B** Threaded post terminals with 10-32 threads are securely fastened to the tubular heating element cold pin, assuring positive electrical contact for maximum amperage carrying capacity. Other terminations are available to accommodate your requirements. See pages 3-10 and 3-11.
- C** The standard Type "S" terminal has specially designed ceramic insulators that provide support to the screw terminals. The tubular heater is recessed into the insulator, to help prevent the screw terminals from bending or breaking from mechanical abuse. Other specially designed ceramic insulators are available for the screw terminals and the connecting wire. See page 3-10.
- D** Specially designed, low expansion 430 stainless steel clamping straps with $\frac{1}{4}$ "-20 socket head cap screws and barrel nuts, in either $\frac{3}{4}$ ", or $1\frac{1}{4}$ " widths, are supplied as our standard method for securing the casting to the barrel. The number and width of the straps is determined by the length and weight of the heater. For optional bolt and nut clamping design see page 3-19 and 3-27.

E Having in-house foundry capabilities gives us the flexibility required to apply sound foundry techniques to control the quality of each casting. Specially designed steel and cast iron molds are used in our Permanent Mold Casting Process, producing a dense casting free of internal voids and drastically reducing porosity, resulting in smoother as-cast surfaces. When processing small quantities, No-Bake Sand Molds are used. This sand casting process produces a better quality casting than other sand processes. The inside diameter of all Cast-In Band Heaters is machine finished to customer specifications.

Processing aluminum castings using a Permanent Mold.



F The most important part in the design of a heat and liquid cool Cast-In Heater is the cooling tube itself, since cooling tube failures usually occur before heating element failures. Tempco has devoted many years of testing and research to develop an alloy tube that is resistant to corrosion, and that will also withstand the continuous stress that is placed on the cooling tube. Our testing has shown that Incoloy® tubing performs best with exposed cooling tube extensions under these harsh conditions, versus stainless steel tubing. Incoloy® is also less susceptible to carbide precipitation, a product of the thermal shock of repetitive heat/cool cycling, that produces internal stress corrosion cracking, a common failure of the cooling tube. We have also learned that using tubing with a .049-inch-thick wall is essential to prevent cracked cooling tubes due to linear thermal expansion as they exit the Cast-In Heater.

Processing aluminum castings using a Sand Mold.



- G** To maintain lower watt densities important for good heater life, the largest possible diameter steel sheath tubular heater is used. Tempco most commonly uses a .430 diameter element with $\frac{1}{8}$ " diameter cold pins. This pin size allows installation of larger and stronger screw terminal connections, providing additional strength to prevent broken terminals due to mechanical abuse.
- H** Cooling tube extensions can be cut to your specified length, with various types of tube fittings factory installed. The casting can also be supplied with non-exposed cooling tube fittings, which reduce cooling tube failure due to stress corrosion cracking. For a complete selection of cooling tube terminations see pages 3-8 and 3-9.



Liquid Cooled Cast-In Band Heaters

The Importance of Liquid Cooling

In the plastic extrusion process, the cooling function of the Cast-In Heater is actually its most important function. The cooling function of the Cast-In Heater has a significant role in modulating the melt temperature of the plastic in the extruder barrel.

In conventional extrusion applications, the liquid cooled method is the most commonly employed. Essentially, this is due to the constructional characteristics of the liquid cooled style cast-in, (see pages 3-4 and 3-5), which facilitates extremely rapid, precise and uniform removal of heat from the extrusion barrel. This quick response-time capability has made Tempco's liquid cooled Cast-In Heaters the primary choice of the extrusion industry.

Because the liquid cooling function of the Cast-In Heater is of primary importance to the extrusion process, Tempco offers many different liquid cooling variations, styles and terminations. Tempco manufactures custom Cast-In Heaters to exact specifications, meeting the requirements of your process. Tempco also offers numerous common sizes and styles of Liquid Cooled Cast-In Heaters off the shelf for immediate delivery. Check the "Standard Sizes and Ratings" on pages 3-14 through 3-18 or call the factory for additional information. The following pages will assist you in selecting the liquid cooling system best suited to your application. See page 3-19 for complete details on how to order.

Single Set of Cooling Tubes—The Industry Standard

The single set cooling tube design features $\frac{1}{4}$ ", $\frac{3}{8}$ " or $\frac{1}{2}$ " diameter tubing precisely formed into a serpentine or any other suitable shape and cast into the body of the Cast-In Heater. This is the most widely used method for providing a means of cooling on liquid cooled Cast-In Heaters.

From this basic design, the user can choose to factory equip the cooling tube extensions with any of the cooling tube termination options shown on page 3-8, and electrical termination options shown on pages 3-10 and 3-11. The two most common designs of mechanical constructions for installation are shown below.



Type CW—Single Cooling Tube with Strap Clamping

Type CW Cast-In Band Heaters consist of liquid cooled and/or heating functions, and are secured to the extruder barrel with $\frac{3}{4}$ " or $1\frac{1}{4}$ " wide low expansion stainless steel clamping straps with $\frac{1}{4}$ "-20 socket head cap screws and barrel nuts.

If not otherwise specified, supplied with Type S electrical screw termination, 3" long cooling tube extensions and straps for clamping. For a wide selection of electrical and cooling tube termination options, see pages 3-8 through 3-11. See page 3-19 for complete details on how to order.



Type CWB—Single Cooling Tube with Bolt Clamping

Type CWB Cast-In Band Heaters consist of liquid cooled and/or heating functions, and are secured to the barrel by bolts clamping the two halves together around the barrel. A variety of bolt clamping designs and hardware are available. Consult Tempco with your specific requirements.

If not otherwise specified, supplied with Type S electrical screw termination and 3" long cooling tube extensions. For a wide selection of electrical and cooling tube termination options, see pages 3-8 through 3-11. See page 3-19 for complete details on how to order.



Type CWW— Dual Set of Cooling Tubes within the Same Cast-In Heater

The Dual cooling tube design incorporates two sets of $\frac{3}{8}$ " or $\frac{1}{2}$ " diameter tubing formed into a serpentine or any other suitable shape within the same Cast-In Heater. Dual cooling tubes will actually double the operating life of a Cast-In Heater with liquid cool function, since cooling tube failures usually occur before heating element failures.

There are two main causes for failure on liquid cooled Cast-In Heaters: Stress corrosion cracking at the exiting point of the tube extensions and clogged lines due to scale build-up that reduce flow, decreasing cooling capacity, and finally completely blocking the tube. Once the first set of cooling tubes has failed, reconnect to the spare set and you are back in operation, thus eliminating costly downtime and additional labor for heater replacement. Dual cooling tubes are also used when additional cooling capacity is required.

Cooling tube extensions can be factory equipped with your choice of fittings. Clamping styles are low thermal expansion alloy straps or bolt clamping. If not otherwise specified, supplied with Type S electrical screw termination, 3" long cooling tube extensions and straps for clamping. For a wide selection of electrical and cooling tube termination options, see pages 3-8 through 3-11. See page 3-19 for complete details on how to order.

Type RC— Non-Exposed Cooling Tubes Recessed NPT Fittings

The recessed cooling tube design incorporates $\frac{3}{8}$ " or $\frac{1}{2}$ " diameter tubing formed into a serpentine or any other suitable shape with specially designed stainless steel NPT fittings that are welded to the tube ends and cast below the surface of the Cast-In Heater, thus eliminating the troublesome, commonly used tube extensions as they exit the casting for connection to the coolant lines.

Non-exposed fittings will drastically increase the operating life of a Cast-In Heater with liquid cool function as this feature eliminates broken and/or damaged cooling tube extensions, which are a major factor in premature heater failure. Type RC fittings are available in two female NPT thread sizes, $\frac{3}{8}$ "-18 and $\frac{1}{2}$ "-14. Standard clamping styles for Cast-In Band Heater sets are low thermal expansion alloy straps or bolt clamping. Specify fitting thread size and clamping style when ordering. If not otherwise specified, supplied with Type S electrical screw termination and straps for clamping. For fittings with special thread size, consult Tempco with your requirements. See page 3-19 for complete details on how to order.

- * **Double operating life**
- * **Greater reliability**
- * **Reduces costly downtime**
- * **Double cooling capacity**
- * **Reduces heater replacement inventory**
- * **Various heater terminations**
- * **Made to customer specifications**



- * **Quick and easy installation**
- * **Exceptionally longer Cast-In Heater life**
- * **Reduces costly downtime**
- * **Greater reliability**
- * **Rugged durable construction**
- * **Available on all cooling tube sizes**
- * **Made to customer specifications**





Cooling Tube Termination Options

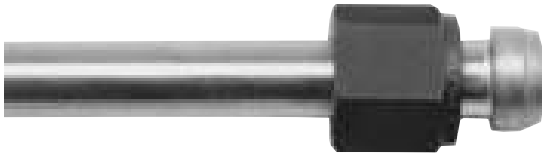

Type BF Brazed Seal Fittings

Brazed seals are excellent for high pressures and temperatures. Recommended to be factory installed to assure good braze seals. Available for $\frac{3}{8}$ " and $\frac{1}{2}$ " diameter tubing.

Diameter Tubing	Thread	Nut Part No.	Sleeve Part No.
$\frac{3}{8}$ "	$\frac{5}{8}$ "-18	FTG-119-101	FTG-119-102
$\frac{1}{2}$ "	$\frac{3}{4}$ "-16	FTG-119-103	FTG-119-104

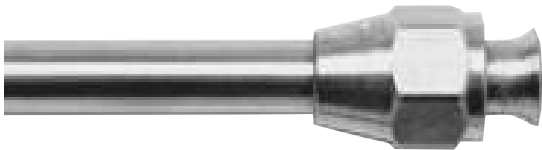

Type FF Flared Seal Fittings

Brass flared seal fittings are well adapted for low to medium pressure and resistant to mechanical pullout. Available for $\frac{3}{8}$ " and $\frac{1}{2}$ " diameter tubing with SAE 45° flare.

Diameter Tubing	Thread	Part Number
$\frac{3}{8}$ "	$\frac{5}{8}$ "-18	FTG-124-101
$\frac{1}{2}$ "	$\frac{3}{4}$ "-16	FTG-124-104



Type HS Hi-Seal Fittings

Hi-seal fittings are highly dependable under the most adverse conditions. For reliable and trouble-free service with ease of installation, we strongly recommend hi-seal fittings. Available for $\frac{3}{8}$ " and $\frac{1}{2}$ " diameter tubing. Male thread is $\frac{1}{2}$ " NPT for $\frac{1}{2}$ " tube and $\frac{3}{8}$ " tube. Fitting is brass.

Diameter Tubing	Part Number
$\frac{3}{8}$ "	FTG-118-120
$\frac{1}{2}$ "	FTG-118-116



Type RA 90° Copper Elbow

90° copper elbow is brazed to the Cast-In Heater cooling tube extension with additional tube extension for connecting cooling lines with compression and/or flared fittings. Available for $\frac{3}{8}$ " and $\frac{1}{2}$ " diameter tubing. If required; specify.

Diameter Tubing	Part Number
$\frac{3}{8}$ "	FTG-127-102
$\frac{1}{2}$ "	FTG-127-103



Type RT Cast Brass 90° Threaded Elbow

90° threaded elbow is brazed to the cooling tube extension, providing an easy and quick method for connecting cooling lines. Recommended to be factory installed to assure good braze seals. Available for $\frac{3}{8}$ " and $\frac{1}{2}$ " NPT internal threads. If required; specify.

Diameter Tubing	NPT	Part Number
$\frac{1}{2}$ "	$\frac{3}{8}$ "	FTG-125-101
$\frac{1}{2}$ "	$\frac{1}{2}$ "	FTG-125-102



Type R3 Straight Threaded Copper Fitting

Straight threaded fitting is brazed to the cooling tube extensions providing an easy and quick method for connecting cooling lines. Recommended to be factory installed to assure good braze seals. Available for $\frac{3}{8}$ " and $\frac{1}{2}$ " diameter tubing with internal threads. If required; specify.

Diameter Tubing	NPT	Part Number
$\frac{3}{8}$ "	$\frac{3}{8}$ "	FTG-131-103
$\frac{1}{2}$ "	$\frac{3}{8}$ "	FTG-131-102
$\frac{1}{2}$ "	$\frac{1}{2}$ "	FTG-131-101



Tubing for Cooling Lines

Tempco offers standard tubing for cooling lines to accommodate the connection of Tempco Cast-In heater/cooler bands and the plumbing system of your extruder. Typical $\frac{3}{8}$ " and $\frac{1}{2}$ " diameters in Incoloy® and stainless steel materials are available off the shelf for immediate delivery.

Diameter	Wall Thickness	Material	Part Number
$\frac{3}{8}$ "	.035"	Stainless Steel	TUB-101-108
$\frac{1}{2}$ "	.049"	Incoloy®	TUB-128-101
$\frac{1}{2}$ "	.049"	Stainless Steel	TUB-101-110

Available in 6'8" lengths for U.P.S. shipments.
Up to 20 ft. for truck shipments.

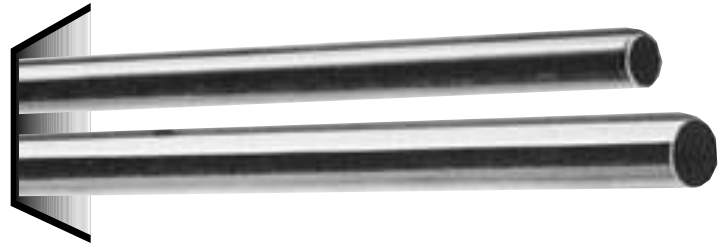

Flexible Teflon® Wire Braided Hose

Flexible Teflon® Wire Braided Hose provides an excellent means of connecting Cast-In Heaters to the extruder plumbing system. This style of hose meets the demands of medium to tight bending radius requirements. The stainless steel braid protects the Teflon® hose from any harsh mechanical conditions that may be present.

A variety of brass male and female threaded fittings can be incorporated onto the hose, making it a practical choice for use in conjunction with Tempco's Style RC Non-Exposed Fittings and other available fittings.

Standard Hose: Size 8 ($\frac{1}{2}$ ") .405" I.D., .549" O.D.

Operating Pressure: 2000 PSI

Burst Pressure: 8000 PSI

How to Order

Standard hose assemblies can be ordered in 6" increments starting at 18". The hose assemblies are supplied with $\frac{3}{8}$ "-18 Male fittings at each end or $\frac{1}{2}$ "-14 Male fittings at each end. Standard Material is Brass.

Type	Part Number*
For $\frac{3}{8}$ "-18 Male fittings	WHT03 <input type="checkbox"/> <input type="checkbox"/> <input type="checkbox"/>
For $\frac{1}{2}$ "-14 Male fittings	WHT04 <input type="checkbox"/> <input type="checkbox"/> <input type="checkbox"/>

*Complete the Part Number with length of hose in 6" increments starting at 18" (018).

Adapter Fittings

Adapter fittings are used to mate the base hose assembly to the fittings you have. Material: Brass.

P1	P2	Type	Part Number
$\frac{3}{8}$ "-18 NPTF	$\frac{3}{8}$ "-18 NPTF	Swivel	FTG-160-104
$\frac{3}{8}$ "-18 NPTF	$\frac{3}{8}$ "-18 NPTM	Swivel	FTG-160-101
$\frac{1}{2}$ "-14 NPTF	$\frac{1}{2}$ "-14 NPTF	Swivel	FTG-160-106
$\frac{1}{2}$ "-14 NPTF	$\frac{1}{2}$ "-14 NPTM	Swivel	FTG-160-103
$\frac{1}{2}$ "-14 NPTF	$\frac{3}{8}$ "-18 NPTF	Swivel	FTG-160-105
$\frac{1}{2}$ "-14 NPTF	$\frac{3}{8}$ "-18 NPTM	Swivel	FTG-160-102
$\frac{3}{8}$ M 45°SAE	$\frac{3}{8}$ "-18 NPTF	Rigid	FTG-161-101
$\frac{1}{2}$ M 45°SAE	$\frac{1}{2}$ "-14 NPTF	Rigid	FTG-161-102

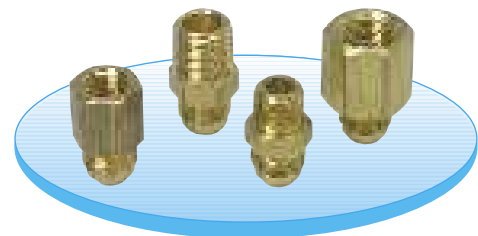



Screw Terminal Terminations

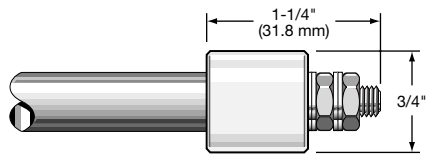

Type S

Heavy duty ceramic insulator for .430" diameter heater with 10-32 screw threads. Standard on Cast-In Heaters unless otherwise specified.

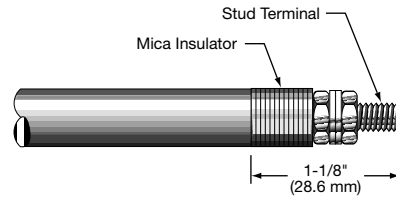

Type T

Mica insulator is the same diameter as the heating element. Available for .260", .315" and .430" diameter heaters. .260" diameter has 6-32 terminal; .315" and .430" have 10-32 terminals.

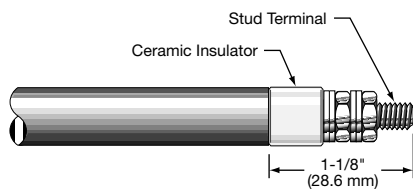

Type T7

Ceramic insulator is the same diameter as the heating element. Available for .260", .315" and .430" diameter heaters. .260" diameter has 6-32 ; .315" and .430" have 10-32 terminals.

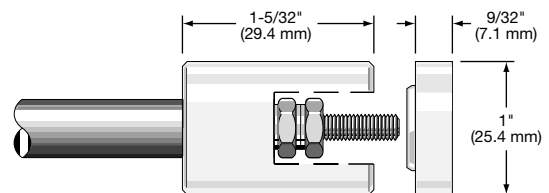

Type C4

Heavy duty ceramic insulator with terminal cover for screw terminal 10-32 thread. Available for .315" and .430" diameter heaters.

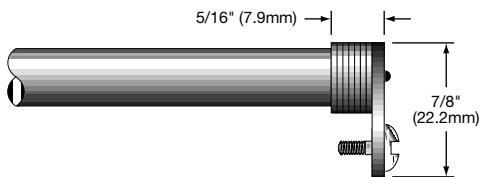

Type E

Right-angle lug welded to pin with mica washer insulators and 10-32 binding head screw. Available for .260", .315" and .430" diameter heaters.

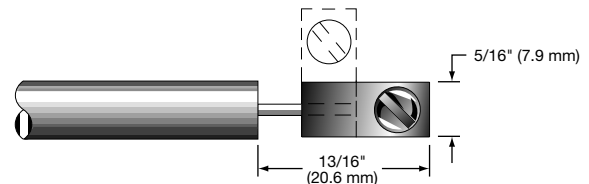

Type L & L9

Terminal lug spot welded to pin with 10-32 binding head screw. Available for .260", .315" and .430" diameter heaters. Type L represents straight; Type L9 represents 90° to pin. Specify lug orientation.

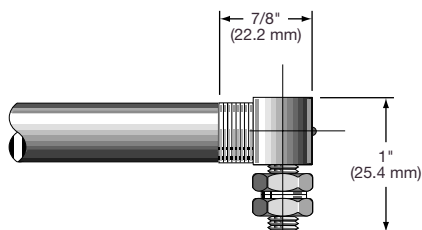

Type R

Mica washers with 90° blockhead screw terminal with 10-32 screw threads. Available for .260", .315" and .430" diameter heaters.

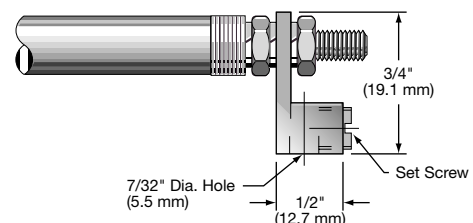

Type R2

Mica washers with blockhead and through hole for lead wire connection. Eliminates the use of ring terminals. Available for .260", .315" and .430" diameter heaters. Accepts 6-14 gauge wire.



Quick-Disconnect Terminations

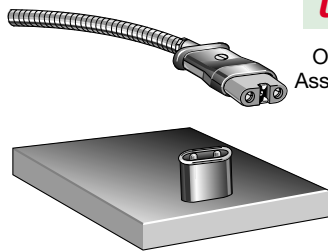

Optional Plug Assembly Shown

Type P1

Quick-disconnect cup assembly mounted directly to casting provides a fast and safe means to apply power to the Cast-In heating element. Available for .260", .315" and .430" diameter elements. Rated 250V max., 15 Amp max.

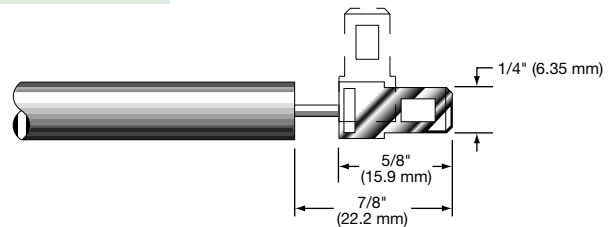

Type SF & SF9

Quick-disconnect spade tabs spot welded to pin. Available for .260", .315" and .430" diameter heaters. Type SF represents straight. Type SF9 represents at 90°. Specify tab orientation.

Flexible Leads

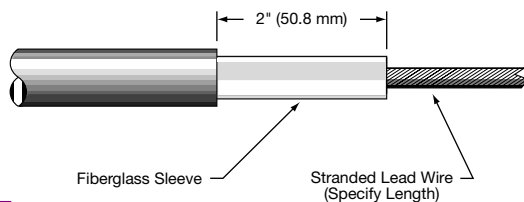

Type F

Flexible lead: insulated stranded wire crimped to cold pin. Crimp connection is insulated with fiberglass sleeving. Available for .260", .315" and .430" diameter heaters. Wire insulation rated to 250°C, 450°C optional. Specify lead length.

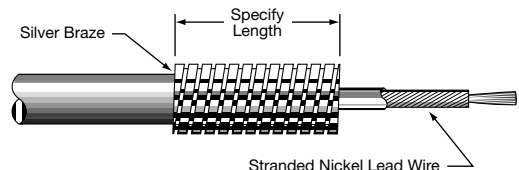

Type R1 Flexible Armor Cable

R1A Stainless Steel Wire Overbraid

Provides excellent protection to lead wires against abrasion and contaminants. Available for .260", .315" and .430" diameter heaters. Specify cable and lead length. Style may vary from depiction depending on heater diameter and cable diameter used.

Moisture/Contamination Seals

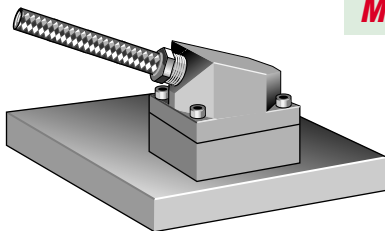

Type DF

Flexible, convoluted, pressure-tight metal hose that provides resistance to heat, pressure and vibration. Male or female fittings can be attached. Specify fitting requirement. Maximum operating temperature is 500°F (260°C).

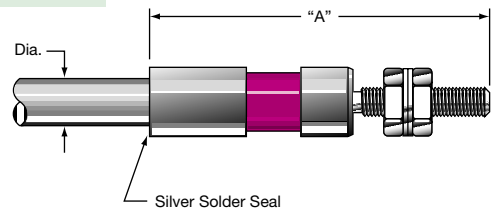

Type H

Ceramic to metal hermetic seal screw terminal. Maximum operating temperature is 1000°F (537°C).

Diameter	.260"	.315"	.430"
"A" Dim.	1 ¹¹ / ₁₆ "	1 ¹¹ / ₁₆ "	2 ¹ / ₈ "
Thread	8-32	10-32	¼-28"

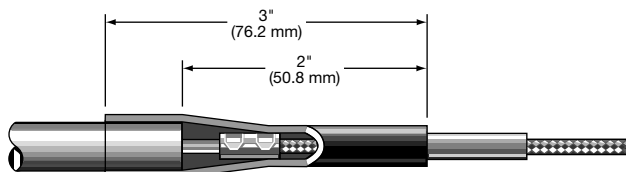

Type MR

Moisture resistant shrink strain relief and lead wire with or without stainless steel overbraid. Available for .260", .315" and .430" diameter heaters. Specify lead wire and overbraid length. Maximum operating temperature is 350°F (176°C).

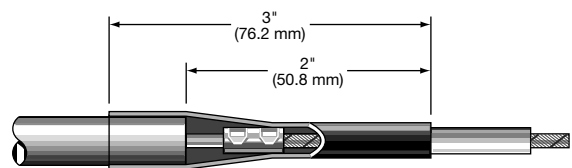

Type TS

Contamination seal shrink-down Teflon® sleeving over the heater and lead wire splice. Provides a good moisture resistant seal. Maximum operating temperature 500°F (260°C). Available for .260" and .315" diameter heaters. Specify lead length.



General Purpose Terminal Boxes

Standard Box Type C2

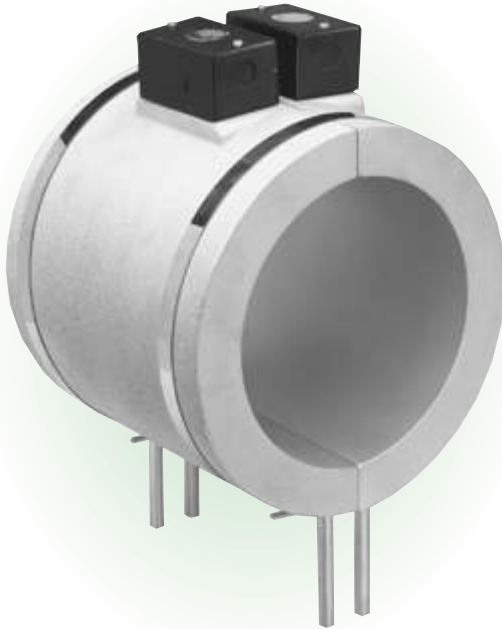

Terminal Boxes provide a simple and economical means to eliminate exposed heater terminals and live electrical wiring, protecting employees from potential electrical shock. They also eliminate electrical shorts that can result from exposed wiring on Cast-In Heater installations.

Type C2 is an individual terminal box for protecting the terminals on each Cast-In Band Heater half. It is also used on many other Cast-In Heater designs with one set of heater terminals. The C2 box design requires a flat pad on half round castings or a flat surface on other casting designs for mounting. Made from heavy gauge rust resistant sheet metal. Cover is removable for easy access to terminals. The box has two $\frac{5}{8}$ " diameter knockouts opposite each other for standard $\frac{3}{8}$ " BX connectors.

To simplify installation, Cast-In Heaters fitted with boxes can be factory pre-wired with high temperature lead wire, protected with armor cable. If either one of these options are required; *specify terminal box type, lead wire and cable length*. Satisfies NEMA 1 requirements.

Standard C2 box size: L = 4", W = 2 $\frac{1}{2}$ " H = 2"

Terminal Protection for Both Heater Halves Type C7

Type C7 terminal boxes are made from rust resistance sheet metal. The C7 base is fixed to the clamping straps. The box has two $\frac{5}{8}$ " diameter knockouts opposite each other for standard $\frac{3}{8}$ " BX connectors. The cover is removable, providing easy access to the screw terminals for electrical wiring.

To simplify installation, Cast-In Heaters fitted with boxes can be factory pre-wired with high temperature lead wire, protected with armor cable. If either one of these options are required; *specify terminal box type, lead wire and cable length*. Satisfies NEMA 1 requirements.

C7 Terminal Box Size varies with dimensions of casting.



Quick-Disconnect High Temperature Cup and Box Assembly Type P2

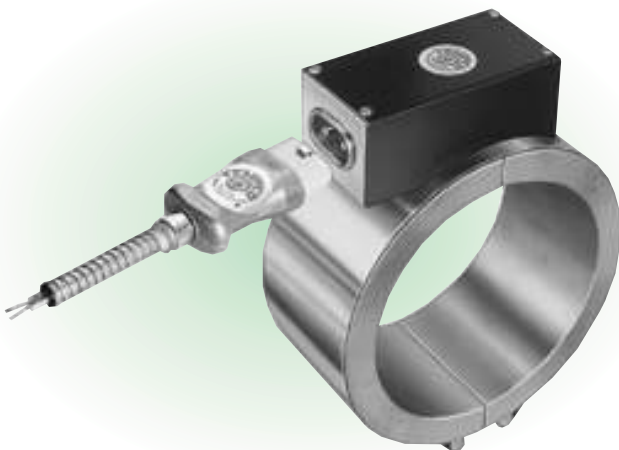

Quick-disconnect cup assemblies provide the simplest and safest means for applying power to any type of Cast-In Heater installation. The box extends over the screw terminals on both Cast-In Band Heater halves. The combination of prewired cup and box assembly, along with factory prewired high temperature lead wire protected with armor cable, eliminates live exposed heater terminals and electrical wiring, protecting employees from electrical shock and the possibility of electrical shorts due to exposed wiring.

If prewired plugs are required, *specify length of lead wire and cable*.

Rated 250V maximum, 15 Amp maximum

Terminal Box Size varies with dimensions of casting.



Terminal Protection Boxes

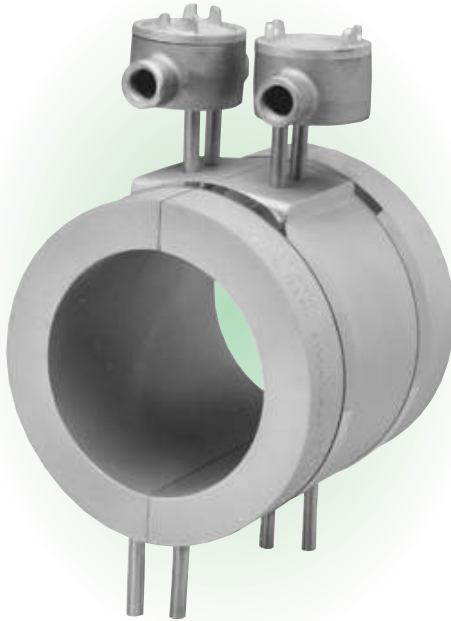

Type EP Explosion and Moisture Resistant Box

Cast Iron explosion and moisture resistant boxes should be used in areas where the surrounding air may become contaminated with combustible gases or a high humidity level may exist. Installation requires one box per Cast-In Heater half and they are brazed to the tubular heater. The standard box has one ½" NPT hub.

Optional: Two hubs per box available. Cast-In Heater fitted with boxes can be factory prewired with high temperature lead wire, protected with special armor cable. If either of these options is required, please specify the following:

- Number of hubs
 - Cable type
 - Lead wire
 - Cable length
- Rated to 450°F (232.2°C).

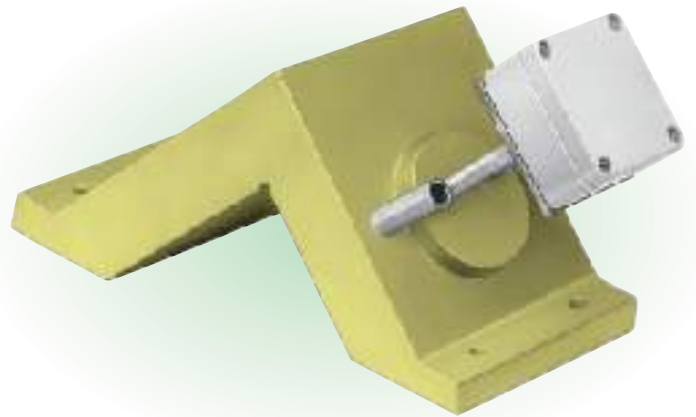

Type MPR

Moisture resistant die cast aluminum box with a non-removable polyurethane gasket in the lid. Lid is secured with captive stainless steel screws. Body and lid are painted in basic industrial gray; interior contains copper ground screw. Box is mounted to a plate that is brazed to the element. Available in a wide variety of sizes. Rated to 250°F (121°C).

Type MR1

This design incorporates the MPR housing style along with a perforated tube shielding unheated extensions of the tubular heating elements. This feature provides mechanical strength to the element extension and prevents overheating of the terminals, reducing possible premature failure from corrosion and oxidation. Rated to 250°F (121.1°C).

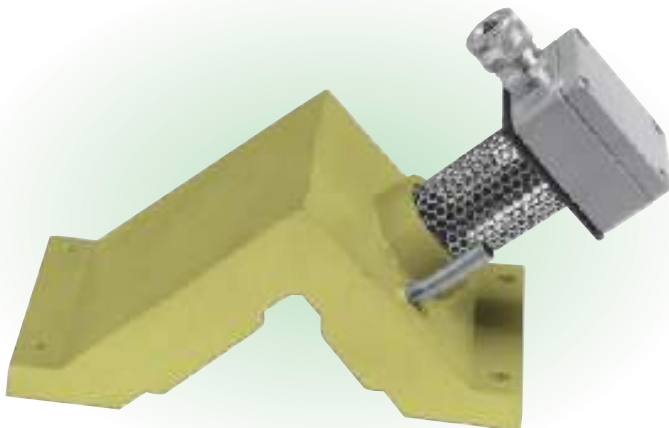

Exposed electrical wiring on cast-in heater installations is a violation of Electrical Safety Codes including O.S.H.A.



Cast-In Band Heaters For Plastic Extrusion and Downstream Equipment

Selecting Standard Cast-In Band Heaters

The Cast-In Band Heater listings on the following pages constitute a small segment of the thousands of Cast-In Band Heaters we have produced for plastics processing equipment. In order to assist you in selecting the exact heater replacement for your machine, adhere to the following instructions:

1. Measure the O.D. of your barrel, which in turn will be the I.D. of the heater.
2. Measure the width of your heater.
3. Check the wattage and voltage rating per half or per segment. This information is normally stamped on the heater.
4. Establish heater cooling function, if any. If water cooled, measure length and diameter of cooling tube extensions. Cooling tube extensions are 3" long, and 1/2" x .049 O.D. wall thickness unless otherwise specified. If air cooled, Cast-In Band will have cast fins.
5. Check for special features such as: thermocouple clearance holes, drill and tapped holes, vent cutouts and terminal boxes.
6. There are two methods for securing a Cast-In Band Heater to a barrel—separate clamping straps or nut and bolt clamping.
7. Once you have established this information, proceed to match your heater description with one of our standard Cast-In Band Heaters. They are listed by extruder size. Starting with the I.D., read across the chart until you have a perfect match. Wattage can vary up to 15% either way with little or no effect to your process.



For sizes, ratings, terminations and/or features not listed, Tempco will manufacture a Cast-In Heater to your specifications. State quantity, watts, volts and full heater description with all the appropriate specifications and features required. See How to Order on page 3-19.

Specifications for Standard Cast-In Band Heaters

1. **Made as sets (two pieces).**
2. **Aluminum, Bronze or Brass alloy.**
3. **Screw Terminals, Type S or R.**
4. **Cooling tube extensions are 1/2" diameter and 3" long standard.**
5. **Complete with one set of clamping straps.**

For additional assistance on Design Specifications see page 3-3.

READ ME...

- **Standard Sizes and Ratings Listed by Extruder Size**
- These Sizes and Ratings are among the most commonly used. They will provide the shortest delivery times.
- Many of these Cast-In Heaters are available Off the Shelf for Immediate Delivery.

STOCK ITEMS
ORDER NOW! *

an asterisk next to the Part Number guarantees in-stock availability for same day shipping when

ORDERED BY **2** PM CST

Extruder Size	I.D. in	O.D. in	Width in	Watts Each Half	Volts	Phase	Cooling Tube O.D.	Features	Part Number
1" to 1 3/4"	3.000	6.500	7.750	1000	460	1	1/2	1" dia. Hole at gap	CBH01911
	3.250	4.500	3.375	400	240	1	N/A	Brass, R1 term., 24" leads w/cable, (1) 1 5/8" dia. hole	*CBH04708
	3.250	6.750	6.500	800	240	1	1/2	(1) 1" dia. Hole centered at gap	CBH05118
	3.250	5.250	7.500	N/A	N/A	N/A	1/2	Cool only, 3 3/4" x 2 3/8" vent	CBH05119
	3.250	4.750	11.500	1175	460	1	N/A	C4 Termination, 1" dia. hole on 1 half only	CBH04909
2" to 2 1/2"	3.625	6.750	4.500	N/A	N/A	N/A	3/8	Cool only, RC - C/T	CBH04375
	4.000	6.000	2.500	375	230	1	N/A		*CBH05632
	4.000	6.000	5.000	N/A	N/A	N/A	1/2	Cool only, w/1" dia. hole at gap	CBH04873
	4.000	6.000	9.500	1500	240	1	N/A	Heat only, (2) T/C holes top gap	CBH03372
	4.375	7.875	12.250	2000	230	1	1/2	(2) 1/8" NPT holes	CBH01595
	4.375	7.875	15.750	3000	230	1	1/2	RC - C/T	CBH05651
	4.375	8.000	16.250	3000	230	1	1/2	(2) 1/8" NPT holes, vented	*CBH01707
	4.500	7.000	3.813	810	240	1	N/A	Heat only	CBH05603
	4.500	7.000	4.375	810	240	1	3/8	T/C hole at gap	CBH01320
	4.500	6.250	10.000	2600	208	1	N/A	Heat only, EP terminal box	CBH04112
	4.500	6.250	10.000	2600	380	1	N/A	Heat only, EP terminal box	*CBH04113
	4.750	6.750	3.625	960	230	1	N/A	Heat only, (2) 3/4" dia. holes E/H	CBH03322
	4.750	7.875	11.813	3000	220	1	3/8	C2 Termination, box E/H	CBH04848
	5.000	8.000	6.750	1000	240	1	1/2	(1) 3/4" dia. Hole at gap on 1 end, BF C/T fittings	CBH01621
	5.000	8.500	8.500	2000	230	1	1/2	RC - C/T	CBH04141
	5.000	8.500	14.000	3300	230	1	1/2	Bolt clamp	CBH05478
	5.000	8.000	16.250	3500	240	1	1/2	Bolt clamp	CBH04518
	5.118	8.618	14.625	5000	240	1	1/2	RC - C/T	CBH04425
	5.250	7.000	7.500	2000	240	1	N/A	Bronze, heat only, bolt clamp, 3" dia. vent hole	CBH01976
	5.250	8.000	12.250	2700	230	1	N/A	2"Lg. slot at gap top/bot. (2) 1/8" NPT holes E/H	CBH04223



Extruder Size	I.D. in	O.D. in	Width in	Watts Each Half	Volts	Phase	Cooling Tube O.D.	Features	Part Number
2" to 2½"	5.500	9.000	3.500	800	240	1	½	RC - C/T	CBH05384
	5.500	9.000	4.000	825	230	1	½		CBH04820
	5.500	8.750	5.500	1050	230	1	¾		*CBH01023
	5.500	8.500	5.500	1050	230	1	¾	EP Terminal box	CBH04672
	5.500	8.750	5.500	1400	230	1	½	C4 Terminal	CBH05266
	5.500	8.750	5.500	1050	190	1	½	C4 Terminal	CBH05698
	5.500	9.000	8.000	2300	240	1	½	C7 Terminal box	CBH03357
	5.500	8.000	8.000	1500	240	1	½	(1) ¾" dia. Hole, RC - C/T	CBH09146
	5.500	9.000	12.000	2325	230	3	½		CBH02858
	5.500	8.000	13.500	3750	240	1	½	(4) ¾" dia. Holes	CBH09133
5.500	7.500	18.000	N/A	N/A	N/A	½	Cool only, RC - C/T	CBH01511	
5.627	9.250	9.000	1550	210	1	½	2 Elements E/H, RC - C/T	CBH03005	
3½" to 4"	6.000	8.000	6.750	2075	230	1	N/A	Heat only	CBH05004
	6.000	8.000	7.500	2000	230	1	¾	RC - C/T	CBH04954
	6.000	7.500	8.250	N/A	N/A	N/A	¾	Cool only	CBH01588
	6.000	9.000	8.500	1500	230	1	½	BF C/T	*CBH04317
	6.000	9.250	9.750	N/A	N/A	N/A	½	Bolt clamp, feed throat cooler	CBH02587
	6.000	9.500	14.250	4150	230	1	½	(1) 1" dia. hole E/H, 2 elements E/H	CBH03483
	6.010	9.250	15.000	4360	240	1	½	Bolt clamp, (1) 1¼" hole, (2) notches at gap	CBH06071
	6.010	9.500	15.500	3500	460	1	½	1½" dia. hole top/bot. gap, self drain C/T	*CBH04999
	6.010	9.500	18.750	4420	460	1	½	1" dia. hole at gap	CBH01812
	6.100	9.500	12.500	2600	105	1	½	RC, 2 elements E/H 105V each element	CBH05337
	6.250	8.250	4.875	600	230	1	N/A	Heat only	CBH05561
	6.250	9.250	9.000	1100	240	1	½	RC - C/T	CBH06093
	6.250	9.750	7.500	3000	240	3	½		CBH05126
	6.250	9.750	8.000	2000	230	1	½	2" slot at gaps	CBH01503
	6.250	11.000	8.250	1300	230	1	½	RC - C/T, weatherhead fitting, single circuit cooling	CBH05634
	6.250	9.250	9.000	1100	240	1	½		CBH05618
	6.250	9.750	8.875	3000	240	3	½		CBH05127
	6.250	9.750	10.438	2500	230	1	½	½" NPT holes E/H, (2) slots at gap	CBH01530
	6.250	10.000	12.375	4000	230	1	½	Bolt clamp, CWW - C/T	CBH03585
	6.250	8.250	12.813	3500	240	1	N/A	Heat only, (2) holes at gap	CBH05101
	6.250	9.750	13.625	3000	230	1	½		CBH01312
	6.250	9.750	15.250	2700	240	1	½	1" dia. Hole on 1 half only	CBH05051
	6.250	10.000	15.875	5000	230	1	½	Bolt clamp, CWW - C/T	*CBH01590
	6.250	10.000	15.875	5000	230	1	½	Bolt clamp	*CBH01726
	6.250	10.000	15.875	5000	280	1	½	Bolt clamp	CBH01818
	6.250	9.750	15.875	3500	230	1	½	Bolt clamp, CWW - C/T	CBH02268
	6.300	9.800	12.000	2500	240	1	½	CWW, RC - C/T, 5½" x 5½" vent	CBH04934
	6.300	9.800	15.750	5000	240	1	½	CWW, RC - C/T	CBH04912
	6.500	10.000	5.000	1100	230	1	½	¾" dia. hole top/bot. at gap	CBH04863
	6.500	9.500	6.000	1250	230	1	½	¾" dia. hole at gap, BF fittings	CBH02575
	6.500	9.750	7.750	1800	230	1	½		*CBH01066
	6.500	9.500	11.000	2300	240	1	½	(1) ¾" dia. hole, HS fittings	CBH06034
6.500	8.500	12.000	N/A	N/A	N/A	½	Cool only	CBH04974	
6.500	10.000	13.000	3750	230	1	½	2 element E/H, 1" dia. hole E/H	CBH02237	
6.500	10.000	13.000	3750	230	1	½	RC, self drain C/T	CBH04142	
6.500	10.000	14.000	3000	240	1	½	Bolt clamp, RC - C/T	CBH05307	
6.500	10.000	16.000	4000	240	1	½	2 Elements each half, 7/8" dia. hole each half	CBH03661	
6.500	10.000	17.500	4500	240	3	½	Self drain C/T, 90° elbow fittings	CBH05188	
6.500	10.000	21.000	4400	230	3	½	¾" dia. hole top/bot. at gap	CBH05094	
6.502	10.000	15.250	4000	230	1	½	5½" dia. vent hole	CBH05437	
6.625	8.625	4.000	1200	230	1	N/A	Heat only	CBH02097	
6.625	8.625	4.500	1150	230	1	N/A	Heat only	CBH05572	
6.625	8.625	8.000	1550	230	1	N/A	Heat only, 6½" dia. vent	CBH03722	
6.635	9.875	17.500	4360	240	1	½	Bolt clamp, (1) notch at gap, (1) 1¼" dia. hole	CBH06070	

Abbreviations

E/H = Each Half	C/T = Cooling tubes
EP = Explosion Resistant Terminal Housing	CW = Single Set of Cooling Tubes
MR = Moisture Resistant Terminal Housing	CWW = Dual Set of Cooling Tubes
MPR = Moisture Proof Die Cast Aluminum Box	RC = Non-Exposed Cooling Tubes/Recessed NPT Fittings

Continued on next page...



Part numbers are for aluminum heaters unless otherwise specified. For Sizes and Ratings not listed, Tempco will manufacture a Cast-In Heater to your specifications. See page 3-19 for how to order.



Standard Sizes and Ratings

Continued from previous page...

Extruder Size	I.D. in	O.D. in	Width in	Watts Each Half	Volts	Phase	Cooling Tube O.D.	Features	Part Number
3 1/2" to 4"	6.750	9.750	8.500	2250	230	1	1/2	(1) 3/4" dia. hole at gap, BF fittings	*CBH05661
	6.750	8.750	8.750	N/A	N/A	N/A	3/8	Cool only	CBH03598
	6.877	10.500	12.250	2640	210	1	1/2	2 elements E/H 105V each element, RC - C/T	CBH03003
	6.877	10.500	12.250	N/A	N/A	N/A	1/2	CW - RC - C/T	CBH05213
	6.999	10.499	18.000	6000	208	3	1/2	C7 Terminal box	CBH04473
	6.999	10.499	18.000	6000	230	3	1/2	1" dia. hole E/H, self drain C/T	CBH05138
4 1/2"	7.000	9.000	4.000	1200	480	1	N/A	Heat only, EP terminal box	CBH05375
	7.500	10.500	6.000	1500	230	1	1/2	BF - C/T	*CBH01033
	7.500	10.500	7.000	1700	230	1	1/2	1" dia. hole top/bot. at gap	*CBH04727
	7.500	11.000	7.750	2400	190	1	1/2	RC - C/T	CBH04984
	7.500	10.500	10.000	N/A	N/A	N/A	1/2	5" x 3 1/2" flange feed throat	CBH04608
	7.500	10.000	10.000	3225	240	1	1/2	(1) 3/4" hole	CBH09142
	7.500	10.500	10.250	2085	230	1	1/2	C2 Terminal box	*CBH01079
	7.500	10.500	10.250	3000	230	1	1/2	C2 Terminal box	*CBH03778
	7.500	11.000	10.250	2085	230	1	1/2		*CBH05192
	7.500	11.000	12.000	3550	240	1	1/2	1" dia. T/C hole at 45°	CBH03921
	7.500	12.500	13.000	3500	230	1	1/2	Bolt clamp, CWW - C/T	CBH02290
	7.500	12.500	13.000	3500	230	1	1/2	Bolt clamp	CBH02296
	7.500	11.000	13.000	5500	230	3	1/2	Bolt clamp	CBH05262
	7.500	11.000	16.500	5100	230	1	1/2	RC - C/T	CBH04660
	7.500	11.000	16.500	4600	230	1	1/2	6 1/2" dia. vent, RC - C/T	CBH05219
	7.500	10.000	17.500	3750	240	1	1/2	(3) 3/4" holes	CBH09052
	7.500	11.000	18.000	4000	240	1	1/2		CBH01146
	7.500	11.000	20.875	7500	230	3	1/2	Bolt clamp, CWW - C/T	CBH03438
	7.500	10.750	20.875	7500	230	3	1/2	Bolt clamp, CWW - C/T	CBH04072
	7.500	11.000	20.875	7500	230	3	1/2	Bolt clamp, (3) holes	CBH03164
	7.500	11.000	21.000	7500	480	3	1/2	1" dia. Hole top gap	CBH04077
	7.560	11.125	18.000	4950	230	1	1/2	Slot at gap	*CBH02240
	7.625	11.125	9.625	2500	230	1	1/2		CBH05089
	7.625	10.625	10.000	3000	240	1	1/2		CBH05319
	7.625	11.125	12.000	3000	240	1	1/2		CBH05320
	7.625	11.125	14.438	3500	240	1	1/2	2" Lg. slot top/bot. gap, (2) 1/8" NPT holes E/H	*CBH01094
	7.625	11.125	18.000	3500	230	1	1/2	2" Lg. slot top/bot. gap, (2) 1/8" NPT holes E/H	*CBH01140
	7.625	11.125	22.500	4700	460	3	1/2	1" dia. Hole E/H	CBH04355
	7.750	9.250	9.813	N/A	N/A	N/A	3/8	Cool only	CBH04937
	7.875	10.875	9.250	1500	240	1	1/2	CWW - C/T, 1/8" NPT hole E/H	CBH04976
	8.000	11.000	5.500	1900	240	1	1/2	Bolt clamp, RC - C/T	CBH06122
	8.000	11.000	6.000	1600	240	1	1/2	RC - C/T	CBH06646
	8.000	11.000	11.500	2000	240	1	1/2	RC - C/T	CBH06630
	8.000	11.000	12.750	2875	240	1	1/2	RC - C/T	CBH06647
	8.000	11.500	12.750	4800	480	3	1/2	Bolt clamp	CBH05369
	8.000	11.500	14.500	5500	480	3	1/2	Bolt clamp	CBH05368
	8.000	11.500	16.500	6000	480	3	1/2	Bolt clamp	CBH05334
	8.250	10.250	7.000	2700	250	1	N/A	Heat only	CBH04941
	8.250	11.750	13.000	5500	460	1	1/2	Self drain C/T, 2 elements E/H	CBH02460
	8.250	11.750	13.000	3850	230	1	1/2	Self drain C/T, RC - C/T, 2 elements E/H	CBH04734
	8.250	11.750	22.000	7950	575	1	1/2	Self drain C/T, 2 elements E/H	CBH04843
	8.270	10.230	7.080	2050	240	1	N/A	Segment heater, EP terminal box E/H	CBH05528
8.500	11.750	18.250	5900	405	3	1/2	Bolt clamp, (6) 3/16" dia. holes, mach. slot @ top gap	CBH06267	
8.500	12.000	6.500	2100	230	1	1/2	3/4" dia. hole top/bot. gap, BF fittings	*CBH01376	
8.500	12.000	8.000	2400	230	1	1/2		CBH01780	
8.500	12.000	8.750	3000	230	1	1/2		CBH01444	
8.500	12.000	14.000	3500	480	3	1/2	1 3/8" dia. Hole E/H	CBH05729	
8.500	12.000	17.000	5900	480	3	1/2	1 3/8" dia. Hole E/H	CBH05696	
8.500	12.000	20.500	5900	480	3	1/2	1 3/8" dia. Hole E/H	CBH05232	
8.510	11.750	18.250	5900	240	3	1/2	(1) 1 1/2" Hole, (3) notches at gap	CBH03489	
8.510	11.750	18.250	5900	240	3	1/2	Bolt clamp, drill and tap (1) 1/8" NPT and (1) 3/8" NPT	CBH06068	
8.750	12.250	11.000	3500	190	1	1/2	RC - C/T	CBH04813	



an asterisk next to the Part Number guarantees in-stock availability for same day shipping when

ORDERED BY **2** PM CST



Extruder Size	I.D. in	O.D. in	Width in	Watts Each Half	Volts Each Half	Phase	Cooling Tube O.D.	Features	Part Number
6"	9.000	12.500	8.000	5000	480	3	1/2	CWW - C/T	CBH05252
	9.127	12.750	16.500	4275	210	1	1/2	RC - C/T, 2 elements E/H,	CBH03152
	9.312	12.625	11.000	3750	230	1	1/2		*CBH05110
	9.313	12.625	11.000	3750	230	1	1/2	C2 Terminal box	*CBH01108
	9.313	12.625	11.000	4950	230	1	1/2	C2 Terminal box	*CBH01133
	9.313	12.625	11.000	3750	230	1	1/2		CBH03051
	9.314	12.620	11.000	3750	230	1	N/A	Heat only	CBH05245
	9.314	12.625	11.000	3750	208	1	1/2		CBH05716
	9.375	11.375	8.250	2500	230	1	N/A	Heat only, type F leads	CBH05426
	9.450	11.000	6.000	2400	230	1	N/A	Heat only, wire braided leads	CBH04809
	9.450	11.000	10.000	4000	230	1	N/A	Heat only, wire braided leads	CBH04810
	9.500	12.000	8.000	2625	230	1	1/2	RA 90° elbow C/T fittings	CBH01784
	9.500	12.625	11.000	3750	230	1	1/2	C2 Terminal box	CBH01169
	9.500	12.000	12.000	3900	230	1	1/2	RA 90° elbow C/T fittings	CBH01698
	9.500	13.000	12.000	3900	240	1	1/2		CBH04916
	9.500	12.000	16.000	5150	240	1	1/2	(1) 3/4" hole	CBH09126
	9.500	12.000	24.500	7850	240	1	1/2	(3) 3/4" holes	CBH09127
	9.500	13.000	27.750	12000	230	3	1/2	Bolt clamp, 1" dia. hole E/H, 1/8" NPT hole E/H	*CBH01528
	9.500	13.000	27.750	12000	230	3	1/2	Bolt clamp, CWW	CBH01816
	9.750	12.750	5.500	1950	230	1	1/2	3/4" dia. Hole top/bot. gap, BF C/T fittings	CBH01059
	9.750	11.750	6.250	2400	230	1	N/A	Heat only	CBH04973
	9.750	12.750	8.500	3000	230	1	1/2	BF C/T fittings, 3/4" dia. hole top/bot. gap	*CBH01057
	9.750	13.250	9.000	3100	230	1	1/2		CBH01532
	9.750	12.750	9.750	3000	230	1	1/2	(2) 1/8" NPT holes E/H	CBH01718
	9.750	13.250	11.000	3500	230	1	1/2	2 Elements E/H, self drain C/T	CBH02461
	9.750	13.250	11.000	4500	230	1	1/2	RC, self drain C/T	*CBH03873
	9.750	13.250	11.000	3600	230	1	1/2	RC, self drain C/T, 8 1/4" dia. cutout top gap	CBH03874
	9.750	13.500	11.750	3750	240	3	1/2		CBH05616
	9.750	13.250	12.000	4500	230	1	1/2		CBH01453
	9.750	13.375	13.000	5280	480	1	1/2		CBH05439
	9.750	13.250	19.000	6750	480	3	1/2	3" Long slot top gap	CBH05064
	9.750	13.000	19.000	6750	480	3	1/2	Bolt clamp	CBH05550
	9.750	13.375	23.875	6000	230	1	1/2	Self drain C/T, 2" Lg. slot top/bot. gap	*CBH01077
	9.750	12.750	24.000	9185	240	1	1/2	2 elements E/H, 12" Lg. slot top/bot. gap	*CBH02183
	9.750	12.750	24.000	9185	240	1	1/2	2 elements E/H, 12" Lg. slot top/bot. gap	CBH05275
	9.750	13.250	25.500	9600	575	3	1/2	1 1/4" dia. hole E/H	CBH04353
	9.760	13.000	12.250	5000	240	3	1/2	Bolt clamp, (5) holes drilled/core, (1) slot	CBH06069
	9.875	13.000	8.500	2000	240	1	1/2	RC - C/T	CBH06648
	9.875	13.000	12.250	4500	240	1	1/2	RC - C/T	CBH06094
	9.875	14.625	8.500	2000	240	1	1/2	2 Layer CWW - C/T w/weatherhead fittings	CBH05401
	9.875	13.500	27.000	6000	240	1	1/2	CWW - C/T	CBH05029
	10.000	13.500	9.000	3700	240	1	1/2		CBH05509
10.000	13.500	12.000	6480	230	3	1/2	Bronze, C2 terminal box, self drain C/T	CBH04498	
10.000	13.500	12.000	3800	240	1	1/2		CBH04905	
10.000	13.500	12.000	6480	230	3	1/2	Self drain C/T	CBH05102	
10.000	13.500	12.000	6480	290	3	1/2	Self drain C/T	CBH05120	
10.000	13.500	12.000	6480	208	3	1/2	Self drain C/T	CBH05190	
10.000	13.500	16.250	5760	480	1	1/2	Self drain C/T	CBH04652	
10.000	13.500	20.000	6000	460	3	1/2	Bolt clamp, RC - C/T	CBH01612	
10.000	13.500	24.000	12500	230	3	1/2	7/8" dia. hole E/H	CBH04304	
10.240	13.750	25.590	8500	105	1	1/2	RC - C/T, 4 elements E/H	CBH05336	
10.500	14.000	21.000	10500	240	3	1/2	Bolt clamp, RC - C/T	CBH05647	
10.500	14.000	28.000	11550	240	1	1/2	12" Lg. slot top/bot., 2 elements E/H	CBH02522	
10.750	14.250	11.000	5500	230	1	1/2	2 Elements E/H	CBH04323	
11.000	14.500	8.000	5000	480	3	1/2	CWW - C/T	CBH03575	
11.220	13.188	5.118	3200	240	1	N/A	EP Terminal box E/H	CBH05525	

Continued on next page...

Abbreviations

E/H = Each Half	C/T = Cooling tubes
EP = Explosion Resistant Terminal Housing	CW = Single Set of Cooling Tubes
MR = Moisture Resistant Terminal Housing	CWW = Dual Set of Cooling Tubes
MPR = Moisture Proof Die Cast Aluminum Box	RC = Non-Exposed Cooling Tubes/Recessed NPT Fittings



Part numbers are for aluminum heaters unless otherwise specified. For Sizes and Ratings not listed, Tempco will manufacture a Cast-In Heater to your specifications. See page 3-19 for how to order.



Standard Sizes & Ratings

Continued from previous page...

Extruder Size	I.D. in	O.D. in	Width in	Watts Each Half	Volts Each Half	Phase	Cooling Tube O.D.	Features	Part Number
8"	11.500	14.750	7.000	5800	230	1	N/A	Heat only	CBH05077
	11.500	14.750	11.625	4700	230	1	1/2	C2 box	*CBH01136
	12.000	14.000	6.000	4000	230	1	N/A	Heat only	CBH04971
	12.000	13.750	8.000	3500	230	1	N/A	1 1/2" x 1 1/2" Corner cutouts at bottom of gap	CBH02402
	12.000	15.500	8.000	2200	240	1	1/2	RC - C/T	CBH06111
	12.000	15.500	8.000	2250	240	1	1/2	C7 Terminal box E/H	CBH05008
	12.000	15.500	12.000	3350	240	1	1/2	C7 Terminal box E/H	CBH05154
	12.000	15.500	23.000	8500	480	3	1/2		CBH05060
	12.250	15.750	12.000	5650	230	1	1/2		CBH01156
	12.250	16.500	12.250	5500	230	1	1/2	Bolt clamp, 7/8" dia. hole E/H	CBH03551
	12.250	16.500	12.250	5500	280	1	1/2	CWW - C/T, bolt clamp, (3) holes	CBH05656
	12.250	15.750	15.000	7000	230	1	1/2		CBH01351
	12.500	16.000	11.000	7500	460	1	1/2	1" dia. hole E/H	CBH02870
	12.500	16.000	14.000	7500	460	1	1/2	1" dia. hole E/H	CBH02868
	12.500	16.000	15.000	8600	480	1	1/2	5 7/8" Cutout at top of gap, self drain C/T	CBH04101
	12.500	16.000	15.000	6750	240	3	1/2	Self drain C/T	CBH04960
	12.500	16.000	15.000	8750	230	3	1/2	Self drain C/T	CBH05359
	12.500	16.000	16.750	9050	240	1	1/2	CWW - C/T	CBH04883
	12.990	14.500	3.500	1750	230	1	N/A	Heat only	CBH04807
	12.999	16.500	13.750	6750	230	1	1/2	CWW, RC - C/T	CBH05357
13.000	16.000	14.500	7000	300	1	1/2	Bolt clamp, RC - C/T	CBH06140	
13.000	16.500	6.000	2900	230	1	1/2		CBH05505	
13.000	16.500	19.000	9300	230	3	1/2		CBH05460	
13.500	17.000	6.500	4250	230	1	1/2		CBH04328	
13.500	17.000	10.000	6500	230	1	1/2	2 Elements E/H, self drain C/T	CBH04324	
13.500	17.250	13.250	5000	460	1	1/2	Segment heater, HS C/T fittings	*CBH05090	
13.500	17.000	18.000	7000	460	3	1/2	CWW, RC - C/T	CBH02601	
13.500	17.250	26.500	10000	460	1	1/2	Segment heater, HS C/T fittings, 120° coverage	CBH01685	
13.500	17.000	26.500	10000	460	3	1/2	CWW, RC - C/T	CBH02602	
13.500	17.250	26.500	10000	575	1	1/2	Segment heater, HS C/T fittings, 120° coverage	*CBH04724	
10"	14.500	18.000	8.000	4350	230	1	1/2		CBH05506
	15.000	18.625	8.000	5000	230	1	3/8	CWW - C/T	CBH03388
	15.000	19.000	15.375	9000	230	1	1/2	Bolt clamp, CWW - C/T	CBH04367
	15.500	19.000	10.000	6750	240	1	1/2	Self drain C/T	CBH05655
	15.500	19.000	19.500	13800	230	3	1/2	Self drain RC - C/T	CBH05358
	15.750	19.250	15.000	10000	277	1	3/8	CWW, C2 terminal box	CBH02242
	17.500	21.000	9.500	4500	240	1	1/2	CWW, RC - C/T	CBH03183
	18.000	20.000	11.500	3500	480	1	N/A	R1 Termination, segment heater, 82° coverage	CBH05002
	19.000	22.500	18.000	15000	460	3	1/2	C7 Terminal box	CBH04880
	20.500	23.000	9.000	6000	240	1	N/A	Heat only	CBH03338
	31.000	33.500	7.500	7500	500	1	N/A	120° segment heater	CBH05712
36.000	40.000	4.500	3500	240	1	1/2	RC - C/T, C2 terminal box	CBH04896	

Abbreviations

E/H = Each Half

EP = Explosion Resistant Terminal Housing

MR = Moisture Resistant Terminal Housing

MPR = Moisture Proof Die Cast Aluminum Box

C/T = Cooling tubes

CW = Single Set of Cooling Tubes

CWW = Dual Set of Cooling Tubes

RC = Non-Exposed Cooling Tubes/Recessed NPT Fittings



an asterisk next to the Part Number guarantees in-stock availability for same day shipping when

ORDERED BY **2** PM CST



Cast-In Band Heater Strap Clamping

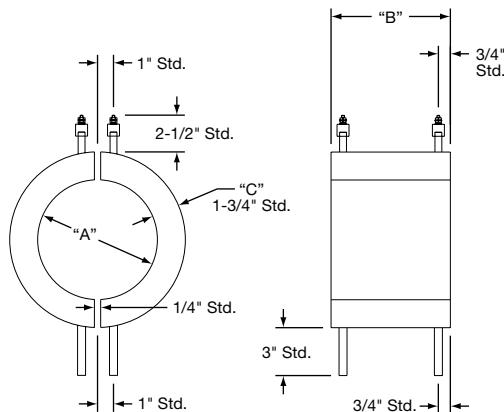

Cast-In Band Heater Bolt Clamping

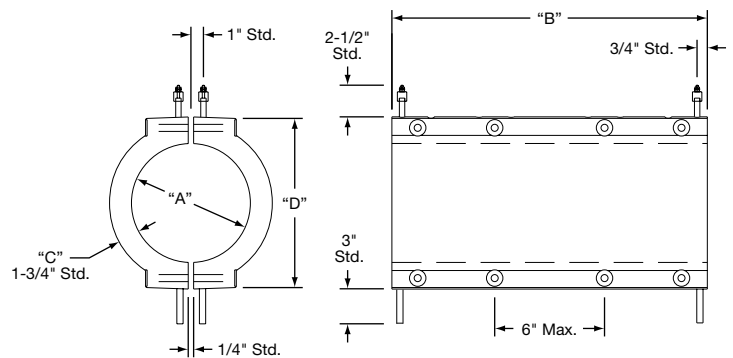

How To Order

To process your order or quotation, please specify the following information.

Variable Dimensions

Inside Diameter "A" _____ Length "B" _____ Thickness "C" _____ "D" _____

Material Specifications

Aluminum Bronze Brass

Electrical Specifications

Watts each half _____ Volts each half _____ Phase _____

Clamping Style

Straps Bolt Clamp

Cooling Tube Sizes

1/4" O.D. SS 3/8" O.D. SS 1/2" O.D. SS Optional Incoloy® (1/2" only) Dual Cooling Tubes

Cooling Tube Fittings

Non-exposed 3/8" NPTF "HS" Hi-Seal Fitting "RA" 90° Copper Elbow
 Non-exposed 1/2" NPTF "BF" High Pressure "RT" 90° Threaded Elbow
 "FF" Flared Seal "R3" Straight Threaded

Terminal Style

"S" Post Terminals "L9" Terminal Lug "C4" Ceramic Cover "F" Plain Leads
 "R" 90° Blockhead "T7" Post Terminals "H" Hermetic Seal
 "L" Terminal Lug "E" Right-Angle Lugs "T" Post Terminals
 "SF"-"SF9" Quick-Disconnect "TS" Leads and Shrink Sleeve
 "R1" Armor Cable Leads "R2" Blockhead and Through Hole

Terminal Protection Box

"C2" Standard "C7" 1 Box for both halves "EP" Explosion Resistant
 "P2" High Temperature Quick-Disconnect "MPR" Moisture Resistant Box
 "MR1" Rigid Moisture Resistant Box

Finish

Machined or As Cast. Indicate surfaces to be machined.

Special Cast-In Features

Holes, Cutouts, Slots, Bevels, Mounting Studs, Stand-Offs and Taper Angles.
For special features a detailed drawing is required.



Air Cooled Cast-In Band Heaters

Why are so many Extrusion Processors converting to Air Cooled Cast-In Heaters?

- ✓ No cooling towers
- ✓ No clogged cooling tubes
- ✓ No leaks or dripping fittings
- ✓ Less expense, low maintenance

A Change Is In The Air

Historically, within many extrusion applications liquid cooled Cast-In Heaters have been the more frequently employed method of modulating the melt temperature of extrusion barrels. There is no doubt about the effectiveness and speed of liquid cooled castings in removing heat from the extrusion process. However, there are a number of drawbacks that primarily relate to maintenance-associated issues.

Extruders that use liquid cooled Cast-In Heaters can be subject to unpredictable and untimely failures of the cooling tube assemblies resulting in extremely costly downtime to the processor. Maintenance problems arising from difficulties with cooling tubes cracking from stress corrosion, linear thermal expansion of the heater body or clogging of the tubes due to accumulation of mineral deposits and sediments are all inherent to liquid cooled type Cast-In Heaters.

Air Cooled Cast-In Heaters represent a practical alternative to the liquid cooling method and have been in use for many years, but have not been as widely used as liquid cooled castings due to the perception of ineffectiveness in cooling rates. This seems to be particularly true in cases with applications of extruders utilizing screws of 4" diameter and greater.

Effective Cooling Through Thermal Efficiency

During the last several years Air Cooled designs have evolved considerably and become more thermally efficient as a result of geometrical changes and implementation of more sophisticated shrouding or air flow techniques. These developments have led to increased usage of Air Cooled Cast-In Heaters on larger machine sizes in favor of Liquid Cooled Cast-In Heater designs.

The cooling effectiveness of Air Cooled Cast-In Heaters can be optimized greatly by carefully employing the proper size and mass constraints to the heater body and determining the appropriate cooling fan rating. Optimized direction and ducting of airflow, coupled with selection of the proper blower motor CFM and horsepower, is all important to ensuring that the air cooling technique removes an adequate amount of BTU's from the extrusion barrel. Tempco's staff of engineers are prepared to provide technical assistance and support to customers when designing Air Cooled Cast-In Heater Systems.

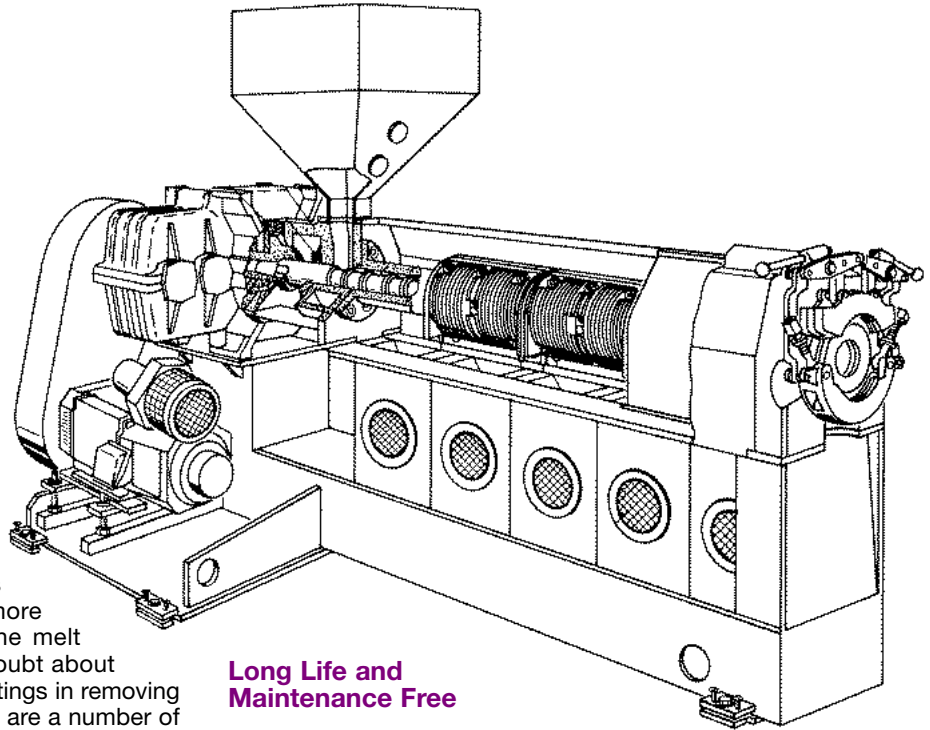

Long Life and Maintenance Free

Air Cooled Cast-In Heaters are virtually maintenance free and therefore, when properly installed and applied, have the capability to far outlast their liquid cooled counterparts. Since cooling tubes are not used, the possibility of breakage, cracking or becoming clogged with brine or mineral deposits is not a concern. This, coupled with the fact that the heat source is a tubular heating element, the most trouble-free and proven heater available, ensures that the reliability of Air Cooled Cast-In Heaters is second to none.

Additionally, Air Cooled Cast-In Heaters do not require an expensive cooling tower or heat exchange system, extensive plumbing systems and labor for installation. These factors along with the benefit of being maintenance free make Tempco Air Cooled Cast-In Heaters an economical and practical source for your extrusion heating and cooling application.

Consult **Tempco** when establishing new designs for your OEM equipment or retrofitting an existing extruder as we will be happy to lend technical assistance.

In the following pages...

Various different fin configurations, clamping, termination and shrouding possibilities are presented. You may also fax or mail to us the "How to Order" section with your specific requirements; this will be reviewed by a qualified Tempco engineer.



Standard Heater Designs for Air Cooled Systems

Finned Cast-In Heaters are designed to operate in Air Cooled Extrusion Systems and are the primary heat source for Tempco's Arctic-Cast® System shown on page 3-28. The thermodynamic relationship of an air cooled system's airflow, fins and heater body yields an extremely effective method of BTU removal from the extrusion process.

The typical finned design of a Cast-In Band Heater incorporates fins that extend 1" in height beyond the O.D. of the casting's body. The casting body is normally 1" thick. The geometry of the fin and number of fins per linear inch of casting width is somewhat flexible based upon application requirements. Normally the optimum distance between the fins, center to center, at the O.D. is 1/2".

As a standard, Finned Cast-In Band Heaters are manufactured in aluminum alloys because this material provides very good thermal conductive properties. For applications requiring higher operating temperatures and/or higher watt densities, bronze or brass alloys can be used.

In certain instances where air cooling alone will not sufficiently cool the process, liquid cooling tubes can be cast into the heater as well to maximize BTU removal.

A computer-designed, precision-formed tubular heating element is the heat source and can be furnished with a wide variety of termination styles for electrical connection.

Precision machining of the inside diameter yields superior heat transfer between the heater and the machine barrel, thereby ensuring uniform heating and cooling of the extrusion process. The heaters are secured to the barrel either by Stainless Steel Clamp Bands or by means of Bolt Clamping the heater halves together.

Finned Cast-In Band Heaters are designed to meet the mechanical and physical constraints of the extruder's shroud and/or cover characteristics. These units are manufactured to individual customer specification and are ideal for new OEM applications and retrofits.

Tempco also offers numerous sizes and styles of Finned Cast-In Heaters off-the-shelf for immediate delivery. Check the "Standard Sizes and Ratings" on pages 3-23 through 3-26 or call the factory for additional information.

Shown below and on the following page are the standard designs for typical air cooled systems including Type FF for Tempco's Arctic-Cast™ Cooling System. See page 3-27 for complete details on how-to-order.

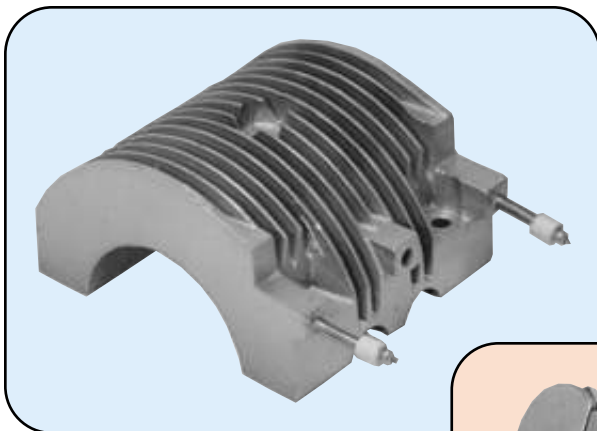

Type P—Bolt Clamp

Features standard 1" high fins and 1" thick body, utilizing bolts and nuts for clamping. Fins cover approximately 100% of heater width. Supplied with Type "S" Termination if not otherwise specified.

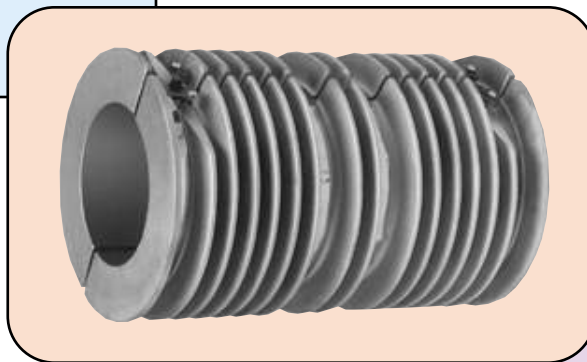

Type F—Strap Clamp

Features standard 1" high fins and 1" thick body, utilizing 1" wide strap clamping at either end of the heater. Fins cover approximately 80% of the heater width. Supplied with Type "S" Termination if not otherwise specified.

Type FF—For Arctic-Cast® Shrouded Systems

Features standard 1" high fins and 1" thick body, utilizing 3/4" to 1" wide clamp straps. A 1" high x 1/4" thick shoulder at each end of the casting mates to the I.D. of the Cast Aluminum Shroud. This unit is normally supplied with Type "E" terminals. Specifically designed for use with Tempco's Arctic-Cast® Systems and can be used for other air cooled applications.

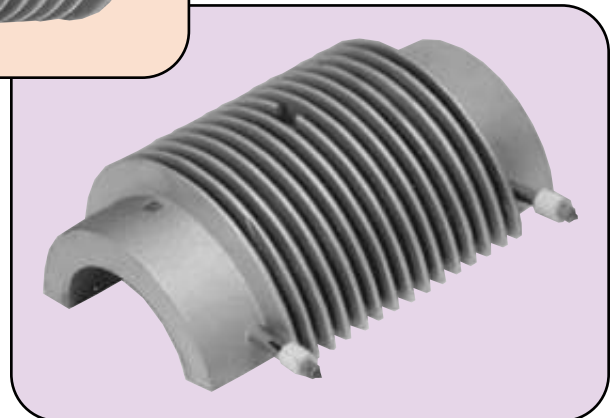



New, Low Profile Unique Design for Smaller Extruders

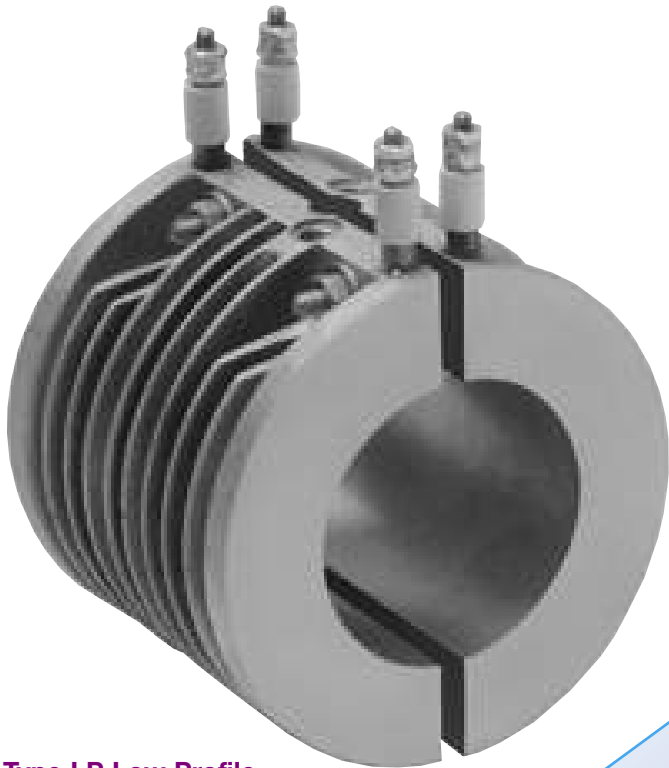

Type LP Low Profile for 1"-1½" Extruders

The Type LP design is intended to be used on smaller tabletop extruders—1" to 1½" screw sizes. This unique design features 1" high fins, which have smaller radii at the fin's crest and root. This results in:

1. Less heater mass to heat up and cool.
2. More cooling fins, yielding greater than normal surface area to dissipate BTU's.

Clamping is achieved by a unique, low profile bolting method that allows the maximum use of surface area for fins, not clamping mechanisms. If not otherwise specified, supplied with Type "S" screw terminals.

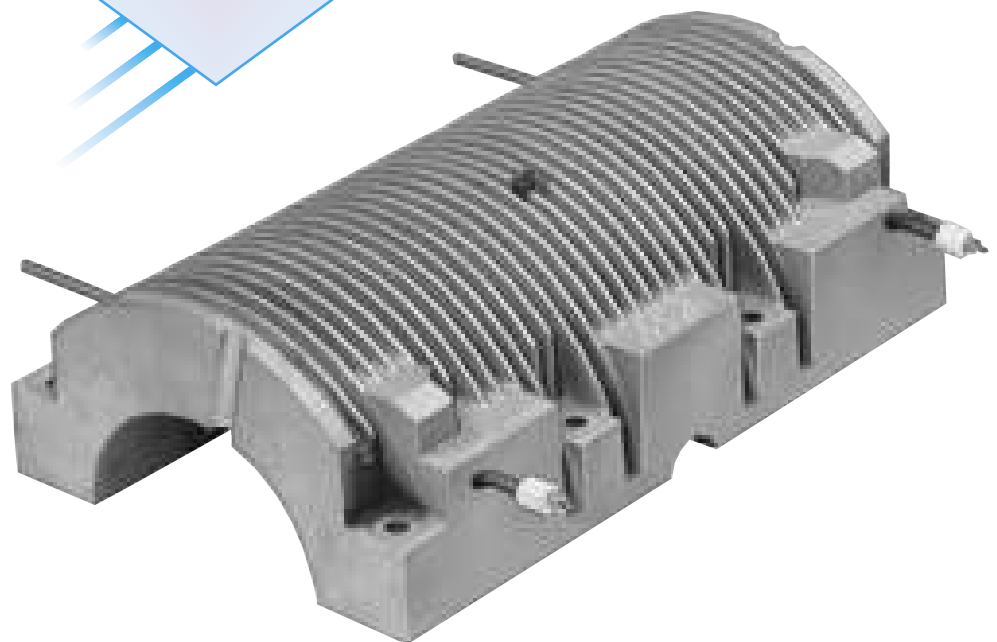
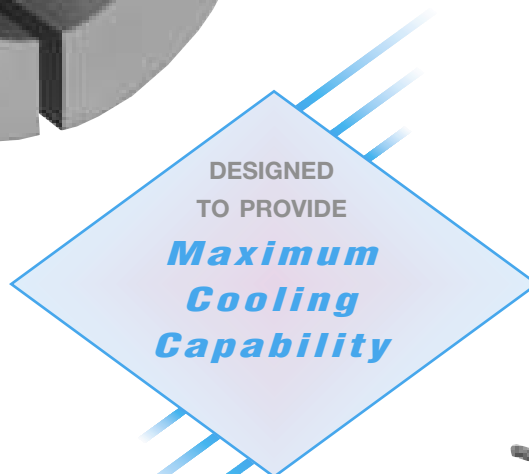

READ ME...

- Standard Sizes and Ratings Listed by Extruder Size
- These Sizes and Ratings are among the most commonly used. They will provide the shortest delivery times.
- Many of these Cast-In Heaters are available Off the Shelf for Immediate Delivery.

Type AW—Dual-Cooling Functions

- Fins for Air
- Cooling Tubes for Liquid

The Type AW Dual Cooling Function design allows the user to maximize cooling capabilities as cast fins and cooling tubes are both incorporated into the heater. Blowers and liquid flow can operate simultaneously for maximum cooling capacity, thus decreasing excess barrel temperatures at extremely rapid rates. This type of design also provides flexibility for individual utilization of either cooling function.

Available with straps or bolt and nut clamping in finned design styles P and F. If not otherwise specified, supplied with Type "S" screw terminals and 3" long cooling tube extensions. This type of Cast-In Heater is manufactured on a specific application design basis—consult Tempco with your requirements.

When ordering, specify finned and clamping style required. See page 3-27 for complete details on how-to-order.



Extruder Size	I.D. in	O.D. in	Width in	Watts Each Half	Volts	Phase	Cooling Tube O.D.	Features	Part Number
1" to 1½"	2.875	5.000	7.500	1100	240	1	N/A	Bolt Clamp, ¾" dia. hole at top of gap	CBH03796
	2.875	5.000	4.125	500	240	1	N/A	Bolt Clamp, ½" dia. hole at top of gap	CBH03853
	2.875	5.000	7.500	1300	240	1	N/A	Bronze, bolt clamp	CBH04506
	2.875	5.000	8.500	1500	230	1	⅜"	Bolt clamp	CBH03840
	2.875	5.000	11.500	800	240	1	N/A	EP Terminal box	CBH02335
	2.875	7.000	7.500	1500	230	1	N/A	Bronze	CBH04619
	2.875	7.000	8.500	1500	230	1	N/A	Bolt clamp	CBH03151
	2.875	7.875	6.000	1125	240	1	⅜"		CBH03257
	3.000	7.000	4.500	1000	240	1	N/A	¾" dia. Hole top/bot. gap	CBH04736
	3.250	5.250	4.375	1000	240	1	N/A		CBH04150
	3.500	7.000	4.500	850	240	1	N/A	Bronze	CBH04194
	3.500	7.000	7.000	1000	230	1	N/A	Heat only, 1" dia. hole on 1 half only	CBH02072
	3.500	7.000	10.000	1500	230	1	N/A	Bronze, 1" dia. hole E/H	CBH02875
	3.500	8.000	5.500	700	220	1	N/A	Bolt clamp	CBH04678
	3.625	6.750	4.000	675	190	1	N/A	Bronze, Type F leads	CBH03149
	3.625	6.750	5.500	375	110	1	N/A	Type F leads, 1" dia. T/C hole top/bot. at gap	*CBH02483
	3.625	6.750	5.500	550	210	1	N/A	Type F leads, 1" dia. T/C hole top/bot. at gap	CBH02792
	3.625	6.750	7.500	675	240	1	N/A	2" dia. Hole at top and bottom gap, Type F leads	CBH02224
	3.625	6.750	7.500	850	240	1	N/A	Bronze, w/2" dia. vent hole, Type F leads	CBH02040
	3.625	6.750	7.500	1500	240	1	N/A	Bronze, w/2" dia. vent hole, Type F leads	CBH04858
2" to 2½"	4.000	7.000	13.000	2250	240	1	N/A	Bolt Clamp, 4" dia. hole	CBH03909
	4.000	8.000	10.750	2000	230	1	N/A	(1) ¾" dia. hole in center at gap, 2½" dia. × 3 hole	CBH03254
	4.000	8.000	10.750	3000	230	1	N/A	Bronze	*CBH04719
	4.000	9.000	5.375	1000	240	1	⅜"	(1) ¾" dia. Hole in center at gap	CBH03256
	4.375	8.250	12.250	2000	230	1	N/A	(2) ⅜" NPT TC holes	CBH03303
	4.375	8.250	12.250	2000	240	1	N/A	Bronze	CBH02166
	4.375	8.250	12.250	2000	230	1	N/A	(2) ⅜" NPT TC holes	*CBH01139
	4.375	8.250	12.250	2500	230	1	N/A	2" Long slot at gaps; term exits perp. to gap	CBH03170
	4.375	8.250	16.250	3000	230	1	N/A	Bronze	CBH03856
	4.375	8.375	4.500	710	230	1	N/A	(2) ⅜" NPT holes	CBH01671
	4.375	8.375	11.000	2250	460	1	N/A	Heat only	CBH05246
	4.375	8.375	12.250	3333	240	1	N/A	Bronze, (2) ⅜" NPT holes	CBH01677
	4.375	9.875	12.250	2000	230	1	½"	2" Lg. slot at gap top/bot.	CBH02189
	4.500	7.500	12.500	2750	460	1	N/A	(1) ⅝" dia. Hole	CBH03973
	4.500	7.500	12.500	2750	460	1	N/A	(1) 3¼" dia. Vent (1) ⅝" dia. hole	CBH03974
	4.500	8.000	9.000	2750	230	1	N/A	⅝" dia. hole on 1 half only	CBH04267
	4.500	8.000	11.000	2000	240	1	N/A	(1) 1¼" dia. Hole E/H	CBH01558
	4.500	8.000	12.500	2750	380	1	N/A	(1) ⅝" dia. Hole on 1 half only	CBH04853
	4.500	8.500	9.750	1550	240	1	N/A	Bolt clamp	CBH06639
	4.500	8.500	9.750	2250	460	1	N/A	Heat only, 3" dia. vent bot. gap	CBH04060
4.500	8.500	9.750	2500	230	1	N/A	Heat only, ⅝" dia. hole on 1 half only	CBH03959	
4.500	8.500	12.000	2350	240	1	N/A	Bolt clamp	CBH06095	
4.500	8.500	12.000	2750	240	1	N/A	Bolt clamp	CBH06640	
4.500	9.000	11.500	2000	230	1	N/A	¾" × 3" slot	CBH05533	
4.500	9.000	12.000	2800	460	1	N/A		CBH04512	
4.500	9.000	12.500	2750	460	1	N/A		CBH03803	
4.750	7.688	7.313	1250	460	1	N/A	(2) 1⅜" dia. holes on 1 half only	CBH01625	
4.750	7.688	7.313	1000	230	1	N/A	118° coverage	CBH02128	
4.750	7.688	7.313	1250	230	1	N/A	(2) 1⅜" dia. holes on 1 half, (1) ⅜" NPT hole on 1 half	CBH02127	
4.877	8.375	7.000	1025	210	1	N/A	2 elements E/H, Type F leads	CBH03273	

Continued on next page...

Abbreviations

- | | |
|---|---|
| E/H = Each Half | C/T = Cooling tubes |
| EP = Explosion Resistant Terminal Housing | CW = Single Set of Cooling Tubes |
| MR = Moisture Resistant Terminal Housing | CWW = Dual Set of Cooling Tubes |
| MPR = Moisture Proof Die Cast Aluminum Box | RC = Non-Exposed Cooling Tubes/Recessed NPT Fittings |



Part numbers are for aluminum heaters unless otherwise specified. For Sizes and Ratings not listed, Tempco will manufacture a Cast-In Heater to your specifications. See page 3-27 for how to order.



an asterisk next to the Part Number guarantees in-stock availability for same day shipping when

ORDERED BY 2^{PM} CST



Standard Sizes and Ratings

Continued from previous page...

Extruder Size	I.D. in	O.D. in	Width in	Watts Each Half	Volts Each Half	Phase	Cooling Tube O.D.	Features	Part Number
2" to 2½"	4.877	8.375	7.000	1750	230	1	N/A	(3) 1" Hole/set	CBH04675
	4.877	8.375	7.000	2400	208	1	N/A	Bronze, 2 elements E/H, Type F leads	CBH03274
	4.877	8.375	8.875	2500	210	1	N/A	Bronze, 2 elements E/H	CBH02794
	4.877	8.375	8.875	2400	240	1	N/A	Bronze, 2 elements E/H	CBH03308
	5.000	7.750	10.875	2500	240	1	N/A	Bolt clamp	CBH03854
	5.000	7.750	12.750	2750	240	1	N/A	Bolt clamp	CBH04159
	5.000	8.000	16.250	3500	240	1	N/A	Bolt clamp	*CBH04477
	5.000	8.000	16.250	3500	240	1	N/A	Bolt clamp, 4" dia. vent	CBH04336
	5.000	8.500	8.500	1900	230	1	N/A	1" dia. hole E/H	CBH02759
	5.000	9.000	11.000	2750	460	1	N/A	3½" dia. Vent	CBH04511
	5.000	9.000	11.500	2650	230	1	N/A	Bolt clamp	CBH05441
	5.000	9.000	12.500	3000	460	1	N/A	5/8" dia. hole on 1 half only	CBH03492
	5.000	9.000	13.000	3500	460	1	N/A		CBH04510
	5.000	9.000	17.000	4000	460	1	N/A	5/8" dia. hole on 1 half only	CBH04084
	5.000	10.250	14.000	3300	230	1	N/A	Bolt Clamp	*CBH03564
	5.250	9.250	14.500	2400	230	1	N/A	1" dia. T/C hole top gap only	CBH04066
	5.250	9.625	6.250	2000	230	1	N/A	7/8" dia. hole bot. gap only 1/8" NPT hole on 1 half only	CBH04613
	5.250	9.750	13.000	2250	240	1	N/A	Bolt clamp, 1" dia. hole at gap	CBH03431
	5.250	10.750	10.250	3000	240	1	3/8"	Bolt clamp, C2 terminal box, 2 elements E/H	CBH01701
	5.500	8.750	3.500	900	240	1	N/A		CBH04418
	5.500	9.000	9.000	1725	230	1	N/A		CBH04193
	5.500	9.500	5.250	1250	230	1	N/A	3/8" Radius, cutout at each end, both halves	CBH01772
	5.500	9.500	8.500	2500	240	1	N/A	Bronze, (1) 1 3/16 dia. hole E/H	CBH03423
	5.500	9.500	10.500	2500	240	1	N/A	4½" dia. Vent hole	CBH04994
	5.500	9.500	12.000	2700	240	1	N/A		CBH04818
	5.500	9.500	12.500	2800	240	1	N/A	Bolt clamp	CBH04982
	5.500	10.000	11.000	2100	230	1	N/A		*CBH02803
	5.500	10.000	14.000	3250	240	1	N/A	5/8" dia. Hole E/H	CBH04964
	5.627	9.375	9.000	1400	220	1	N/A	Bolt clamp	CBH02041
	5.750	9.750	11.500	1800	220	1	N/A	2" dia. hole at top and bottom gap	CBH03195
5.750	10.250	13.000	2700	230	1	N/A		CBH05404	
3½"	6.000	10.000	11.000	3500	480	1	N/A	Bolt clamp, 2 elements E/H	CBH04145
	6.000	10.000	14.500	3000	220	1	N/A	Term. 90° fr. gap, Hole/dia.: (2) 1" E/H, 1½" bot. gap	CBH04175
	6.000	10.500	11.500	2700	230	1	N/A	Slot at gap	CBH02588
	6.000	10.500	14.500	3500	230	1	N/A	Slot at gap	CBH02432
	6.000	11.250	2.750	500	230	1	N/A	Bolt clamp	CBH03539
	6.010	10.000	15.000	4360	240	1	N/A	Bolt clamp	CBH06534
	6.250	9.250	18.000	5000	240	1	N/A	Bolt clamp, 5¾" dia. vent at gap	CBH04383
	6.250	10.000	15.250	3000	240	1	N/A	Term. 90° from gap, 2 elem. E/H, 2" Lg. slot top gap	CBH01773
	6.250	10.125	8.000	2750	230	1	N/A	Bronze	CBH02600
	6.250	10.250	6.250	1400	240	1	N/A	Bolt clamp	*CBH04382
	6.250	10.250	6.250	1700	240	1	N/A	Bolt clamp	CBH06373
	6.250	10.250	10.438	2500	230	1	N/A	2" Lg. slot at top gap, (2) 1/8" NPT holes at top gap	*CBH01708
	6.250	10.250	13.688	3000	230	1	N/A	2" Lg. slot at top gap, (2) 1/8" NPT holes E/H	*CBH01406
	6.250	10.250	14.000	4400	240	1	N/A	Bolt clamp	CBH06089
	6.250	10.250	14.500	5000	275	1	N/A	7/8" dia. Hole E/H	CBH05242
	6.250	10.250	17.500	6000	220	1	N/A	1" dia. hole E/H	CBH05342
	6.250	10.250	17.750	5800	240	1	N/A	Bolt clamp, 2 elements E/H	CBH06623
	6.250	11.000	15.875	5000	230	1	N/A	Bronze, bolt clamp	CBH02176
	6.250	11.250	15.875	5000	230	1	N/A	Bolt clamp	CBH03797
	6.250	11.500	9.375	4628	280	1	N/A	Bolt clamp	CBH02066
	6.250	11.500	13.000	4000	230	1	1/2"	Bolt clamp	CBH01977
	6.250	11.500	15.875	4000	230	1	N/A	Bolt clamp	CBH02005
	6.253	10.250	14.000	4400	240	1	N/A	Bolt clamp, 2 elements E/H	CBH06089
	6.300	9.500	15.750	5000	240	1	N/A	M12-6 tap on 1 half only, 5/8" dia. hole top gap	CBH03793
	6.500	9.500	5.500	1500	240	1	N/A		CBH02609
	6.500	9.625	5.500	1500	240	1	N/A		CBH03016
	6.500	9.750	15.750	5000	240	1	N/A	6½" dia. vent	CBH04715

Abbreviations

- E/H = Each Half
- EP = Explosion Resistant Terminal Housing
- MR = Moisture Resistant Terminal Housing
- MPR = Moisture Proof Die Cast Aluminum Box
- C/T = Cooling tubes
- CW = Single Set of Cooling Tubes
- CWW = Dual Set of Cooling Tubes
- RC = Non-Exposed Cooling Tubes/Recessed NPT Fittings



Standard Sizes and Ratings

Extruder Size	I.D. in	O.D. in	Width in	Watts Each Half	Volts Each Half	Phase	Cooling Tube O.D.	Features	Part Number
3 1/2"	6.500	10.000	17.000	4500	240	3	N/A	3/4" High fins	CBH04842
	6.500	10.500	7.500	2000	230	1	N/A	3/8" Radius cutout each end E/H	CBH03321
	6.500	10.500	7.500	2000	230	1	N/A	Bronze	CBH04968
	6.500	10.500	13.000	3750	230	1	N/A	Bolt clamp	CBH04953
	6.500	10.500	15.000	3850	240	1	N/A		CBH05560
	6.500	10.500	19.000	2000	240	1	N/A	(2) Elements E/H, 1" dia. hole on 1 half only	CBH05240
	6.500	10.750	11.000	3250	190	1	N/A	1" dia. hole both halves	CBH04434
	6.500	10.750	13.000	4500	230	1	N/A	1" dia. hole both halves	CBH04555
	6.500	10.750	13.000	4100	230	1	N/A	Bronze	CBH04584
	6.500	11.000	7.750	1800	230	1	N/A	2 Elements E/H	CBH01906
	6.500	11.000	17.500	3600	230	1	N/A		*CBH02802
	6.625	10.625	14.750	6900	230	3	N/A	(3) 1 1/2" Lg. slots at top gap, 1 1/4" dia. hole E/H	CBH04287
	6.625	11.000	17.000	2300	240	1	N/A		CBH04034
	6.625	11.000	17.500	2300	240	1	N/A		CBH04130
	6.750	10.750	10.000	4500	240	1	N/A	Bronze	CBH03436
	6.750	11.250	16.000	4800	230	1	N/A		CBH05405
	6.877	10.000	12.250	2640	210	1	N/A	Bolt clamp, 2 elements E/H, 105 V each element	CBH04500
	4 1/2"	7.000	11.000	17.500	5000	480	1	N/A	
7.500		11.000	16.500	3500	240	1	N/A	1 1/2" dia. Hole at gap	CBH05722
7.500		11.000	16.500	4600	230	1	N/A	7 1/2" dia. Vent	CBH05451
7.500		11.000	16.500	4600	208	1	N/A	7 1/2" dia. Vent	CBH05641
7.500		11.000	16.500	5000	240	1	N/A		CBH05721
7.500		11.000	16.500	5100	230	1	N/A	Bronze, (2) elements E/H, (2) 1" dia. holes E/H	CBH02748
7.500		11.000	16.500	5100	230	1	N/A	Euro ground post terminal	CBH04696
7.500		11.500	10.875	3500	240	1	N/A		CBH04269
7.500		11.500	11.281	3500	240	1	N/A		CBH04270
7.500		11.500	21.000	7500	230	1	N/A	Used with shroud ASF1025	CBH05122
7.500		11.750	13.000	3800	230	1	N/A	Bronze, 4 3/4" dia. vent	CBH03361
7.500		11.750	13.000	4000	230	1	N/A	Bronze	CBH03362
7.500		12.000	10.250	2085	230	1	N/A	1" dia. hole top/bot. gap	*CBH01314
7.500		12.000	17.000	3500	230	1	N/A		CBH05395
7.500		12.000	18.000	3500	230	1	N/A		CBH05574
7.500		12.000	22.000	6000	230	1	N/A		CBH05396
7.500		12.500	13.000	5000	230	1	N/A	Bolt clamp	CBH01955
7.500		12.500	20.875	7500	230	3	1/2	Bolt clamp, CWW C/T, 5 1/4" dia. vent	*CBH01958
7.500		12.750	20.875	7500	230	3	N/A	Bolt clamp	*CBH01665
7.500		12.875	12.500	2500	230	1	3/8	Bolt clamp	CBH05559
7.500		13.000	16.250	5000	230	3	1/2	Bolt clamp	CBH03910
7.500		13.000	17.375	4000	230	1	1/2	Bolt clamp	CBH03383
7.500		13.000	20.875	5000	230	3	1/2	Bolt clamp	CBH01993
7.500		13.000	23.000	7500	230	1	N/A	Bolt clamp, 3 vent holes	CBH01978
7.560		12.250	18.000	4950	230	1	N/A	6" Lg. slot top/bot. gap	CBH03098
7.625		11.500	14.438	3700	240	1	N/A		CBH05691
7.625		11.500	18.000	3500	230	1	N/A	1 3/8" Lg. slot at top gap, (2) 1/8" NPT holes E/H	CBH02252
7.625		11.625	14.438	3500	230	1	N/A	2" Lg. slot at top gap, (2) 1/8" NPT holes E/H	CBH01401
7.625		11.625	14.438	3500	275	1	N/A	Bronze	CBH03667
7.625		11.625	14.438	5000	275	3	N/A	Bronze	CBH04621
7.681	11.750	9.125	4000	230	1	N/A	Bolt Clamp	CBH03985	
8.000	12.000	6.750	1700	575	1	N/A	3/4" dia. Hole E/H	CBH01682	
8.000	12.300	6.500	2212	240	1	N/A	Bolt clamp	CBH06641	
8.000	12.000	8.000	2500	240	1	N/A	Bolt clamp	CBH06574	
8.000	12.000	8.000	2850	240	1	N/A	Bolt clamp	CBH06642	
8.000	12.000	10.000	3550	240	1	N/A	Bolt clamp	CBH06643	
8.250	12.250	13.000	5500	240	1	N/A	1" dia. Hole E/H	*CBH04892	
8.250	12.250	16.000	7000	230	3	N/A	Bolt clamp, 1" dia. hole E/H	CBH05247	
8.250	12.250	16.000	9750	190	3	N/A	Bolt clamp, 1" dia. hole E/H	CBH05487	
8.250	12.500	19.500	11000	190	1	N/A	2 Elements E/H, ground post terminal E/H	CBH05073	

Continued on next page...



an asterisk next to the Part Number guarantees in-stock availability for same day shipping when



Part numbers are for aluminum heaters unless otherwise specified. For Sizes and Ratings not listed, Tempco will manufacture a Cast-In Heater to your specifications. See page 3-27 for how to order.



Standard Sizes and Ratings

Continued from previous page...

Extruder Size	I.D. in	O.D. in	Width in	Watts	Volts	Phase	Cooling Tube O.D.	Features	Part Number	
4½"	8.268	11.504	21.457	7500	240	3	N/A	M12 Hole E/H, 5/8" dia. hole top gap	*CBH04167	
	8.500	12.000	8.500	2750	230	1	N/A		CBH05417	
	8.500	12.500	5.750	2000	300	1	N/A		CBH05253	
	8.500	12.500	6.000	1250	240	1	N/A		CBH04854	
	8.500	12.500	18.000	5500	240	1	N/A		CBH05287	
	8.500	12.500	20.000	5750	240	3	N/A	1" dia. Hole top gap	CBH05234	
	8.500	13.000	19.000	6000	480	1	N/A		CBH05227	
	8.660	13.125	8.000	3000	230	1	N/A		CBH03508	
6"	9.125	12.250	16.500	4275	210	1	N/A	Bolt clamp, type F leads	CBH03608	
	9.127	12.250	16.500	4275	210	1	N/A	Bolt clamp, 2 elements E/H, Type F leads	CBH03082	
	9.250	14.375	13.250	3500	230	1	N/A	Bolt clamp	CBH02324	
	9.250	14.750	5.250	1250	230	1	N/A	Bolt clamp, (2) 2" dia. hole E/H	CBH02328	
	9.313	13.813	23.500	9900	230	1	N/A		CBH05327	
	9.313	13.813	23.500	7500	230	1	N/A		CBH05445	
	9.313	13.813	23.500	7500	460	3	N/A		CBH05515	
	9.313	13.813	28.500	7500	230	1	N/A		CBH05447	
	9.313	13.813	28.500	9900	460	3	N/A	1" dia. hole top gap	CBH05513	
	9.313	13.813	28.500	7500	460	3	N/A	1" dia. hole top gap	CBH05514	
	9.500	13.500	19.375	8000	230	1	½	Bolt clamp, 2 elements E/H	CBH03165	
	9.500	14.750	12.000	5000	230	1	N/A	Bolt clamp, 1/8" NPT hole E/H	CBH04151	
	9.500	15.000	13.750	7250	230	1	½	Bolt clamp	CBH02185	
	9.500	15.000	18.500	4000	230	1	½	2 elements E/H, bolt clamp	CBH03583	
	9.500	15.000	27.750	12000	230	3	N/A	Bolt clamp, 1/8" NPT hole E/H	*CBH01666	
	9.500	15.000	27.750	7500	230	3	N/A	Bolt clamp, 4 1/4" dia. hole E/H	CBH04561	
	9.625	11.625	14.437	5000	287	3	N/A	(2) 1/8" NPT holes E/H, 7/8" slot top gap, Brass	CBH04751	
	9.750	13.250	7.500	2750	460	1	N/A		CBH05474	
	9.750	13.750	13.500	5688	240	1	N/A		CBH04131	
	9.750	13.750	19.000	7500	480	3	N/A	Bolt clamp	CBH05684	
9.750	13.750	22.000	9000	190	3	N/A	Bolt clamp, 1" dia. hole E/H	CBH04427		
9.750	14.000	19.438	6000	230	1	N/A	2" Lg. slot top gap	*CBH01262		
9.750	14.000	23.875	6000	230	1	N/A	2" Lg. slot top/bot. gap	CBH02945		
9.758	12.000	20.000	7650	240	3	N/A	Bolt clamp, (3) EP terminal boxes E/H	CBH04772		
9.875	13.875	8.500	3500	240	1	N/A	Bolt clamp	CBH06644		
9.875	13.875	8.500	3750	240	1	N/A	Bolt clamp	CBH06645		
10.039	13.289	12.992	6000	230	3	N/A		CBH04738		
10.750	14.250	9.250	4400	380	1	N/A		CBH05410		
8"	11.000	15.000	22.000	11000	110	3	N/A	Bolt clamp	CBH04429	
	11.500	16.000	11.375	4700	240	1	N/A		CBH01232	
	12.127	15.750	22.000	7050	210	1	N/A	2 Elements E/H @105V each	CBH03006	
	12.127	15.750	22.000	7050	290	1	N/A	2 Elements E/H @145V each	CBH05614	
	12.250	14.000	12.250	5500	230	1	N/A	Bolt clamp	CBH03348	
	12.250	16.250	8.000	2800	230	1	N/A		CBH03935	
	12.250	18.250	11.875	5000	230	1	N/A	Bolt clamp	CBH05290	
	12.250	18.500	11.562	5500	230	1	N/A	Bolt clamp, 7/8" dia. hole E/H	CBH05455	
	12.250	18.500	11.875	5500	230	1	N/A	Bolt clamp	CBH02088	
	12.250	18.500	12.250	5500	230	1	N/A	Bolt clamp, Bronze	CBH03765	
	12.250	18.500	12.250	3000	230	1	N/A	Bolt clamp, 6 1/2" radius, cutout on 1 half only, Bronze	CBH03767	
	12.250	18.500	19.000	5500	230	1	N/A	Bolt clamp	CBH04069	
	10"	14.000	18.000	4.000	5000	480	1	N/A		CBH03518
		14.625	18.625	4.000	5000	480	1	N/A		CBH03519

Abbreviations

- | | |
|---|---|
| E/H = Each Half | C/T = Cooling tubes |
| EP = Explosion Resistant Terminal Housing | CW = Single Set of Cooling Tubes |
| MR = Moisture Resistant Terminal Housing | CWW = Dual Set of Cooling Tubes |
| MPR = Moisture Proof Die Cast Aluminum Box | RC = Non-Exposed Cooling Tubes/Recessed NPT Fittings |



Part numbers are for aluminum heaters unless otherwise specified. For Sizes and Ratings not listed, Tempco will manufacture a Cast-In Heater to your specifications. See page 3-27 for how to order.



an asterisk next to the Part Number guarantees in-stock availability for same day shipping when

ORDERED BY 2 PM CST



Finned Cast-In Band Heater Strap Clamping

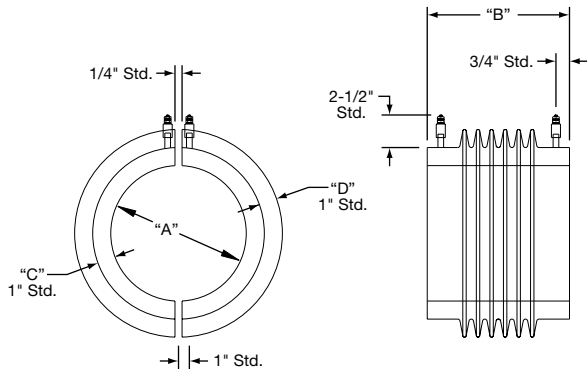

Finned Cast-In Band Heater Bolt Clamping

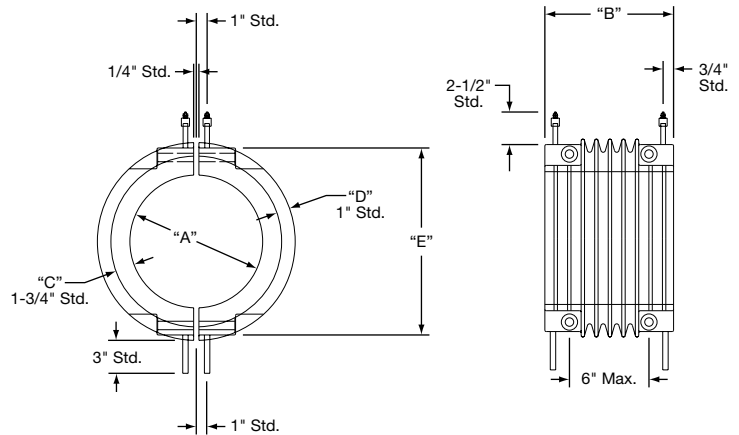

Specify size and location of bolt holes.

How To Order

To process your order or quotation, please specify the following information.

Variable Dimensions

Inside Dia. "A" _____ Length "B" _____ Thickness "C" _____ Fin Height "D" _____ "E" _____

Material Specifications

Aluminum Bronze Brass

Electrical Specifications

Watts each half _____ Volts each half _____ Phase _____

Clamping Style

Straps Bolt Clamp

Cooling Tube Sizes

1/4" O.D. SS 3/8" O.D. SS 1/2" O.D. SS Optional Incoloy® (1/2" only) Dual Cooling Tubes

Cooling Tube Fittings

Non-exposed 3/8" NPTF "HS" Hi-Seal Fitting "RA" 90° Copper Elbow
 Non-exposed 1/2" NPTF "BF" High Pressure "RT" 90° Threaded Elbow
 "FF" Flared Seal "R3" Straight Threaded

Terminal Style

"S" Post Terminals "T7" Post Terminals "C4" Ceramic Cover
 "R" 90° Blockhead "F" Plain Leads "H" Hermetic Seal "T" Mica Washers
 "SF" Quick-Disconnect "R1" Armor Cable Leads "TS" Leads and Shrink Sleeve
 "SF9" Quick-Disconnect "E" Right-Angle Lugs "L"-"L9" Terminal Lug
 "R2" Blockhead and Through Hole

Terminal Protection Box

"C7" 1 Box for both halves "EP" Explosion Resistant "MPR" Moisture Resistant Box
 "P2" High Temperature Quick Disconnect

Finish

Machined or As Cast. Indicate surfaces to be machined.

Special Cast-In Features

Holes, Cutouts, Slots, Bevels, Mounting Studs, Stand-Offs and Taper Angles.
 For special features a detailed drawing is required.

When *cool* isn't cool enough
for your extrusion process!

Let the experts show you how to
improve on controlling the process
temperature of the melt...

TURBOCHARGE

your Extruders with Tempco's

Arctic-Cast[®]

turnkey ready-to-go thermally efficient
heating and air cooling systems
with advanced design
features providing
Hi-Tech Performance.

Ahhh!... A few
degrees can
make things
downright
cozy.



Arctic-Cast[®]

Making an Impact on Extrusion with World Class Technology.



Arctic-Cast® Heating and Air Cooling System

Designed for Improved Operation, Efficiency, Ease of Installation, Trouble Free Performance and Optimal Durability

Arctic-Cast® systems are manufactured for heating and air cooling the barrels of plastic processing extrusion equipment.

These systems are an innovative and novel concept in product design consisting of a unique combination of highly engineered components to perform in unison, achieving maximum thermal and operating efficiency. Being self contained and turnkey ready-to-go, they will have you up and running much faster, requiring minimum labor and cost for installation, drastically reducing downtime and maintenance upkeep versus conventional liquid cool/heat cast-in heaters.

Improve your process efficiency and increase productivity by retrofitting your existing equipment or by specifying Tempco's exclusive Arctic-Cast® systems to your OEM machine builder on your next extruder purchase.

How to spec-out a system?

Simply consult Tempco's team of professionals who will help you . . . TURBOCHARGE YOUR EXTRUSION EQUIPMENT.

Additional Design Features

- * Turnkey ready-to-go system
- * Reduces operating costs
- * Quick, easy installation
- * Greater reliability
- * Thermally efficient heating and cooling characteristics
- * Drastically reduces costly downtime
- * Flexible design capable of covering entire zone or a portion
- * Exceptionally long Cast-In Heater life
- * Eliminates expensive closed loop liquid cooling systems
- * Rugged durable construction
- * Cosmetically appealing design
- * Made to customer specifications
- * Eliminates expensive sheet metal shrouds

Arctic-Cast® System featuring – finned cast-in band heater with strap clamping, cast aluminum single port clamshell shroud, and blower assembly with optional cast aluminum housing and air intake filter.

Adaptor Plates

Custom blower port mount adaptor plates are available to match Tempco's existing Arctic-Cast® shrouds to your blower mounting pattern.

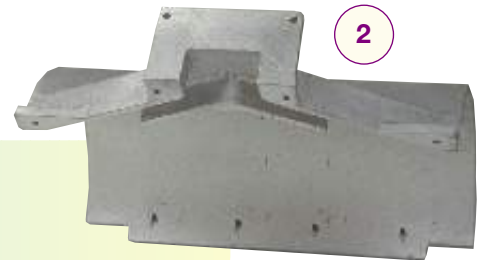
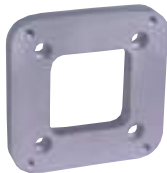

Arctic-Cast® System Integral Componentry

1 Finned cast-in band heaters incorporate a computer designed tubular heating element that is precisely formed, placed into a mold and cast into aluminum for optimum thermal conductivity.

The thermal efficiency of the specially designed cast-in band heater is optimized by controlling the relationship between the mass of the heater body and the unique geometrical design and size of the fin.

Cast-in band heaters are made in sets and they require a clamping mechanism. Two clamping design methods are available: (A) strap clamping, (B) bolt and nut clamping. For details, see page 3-27.

The standard termination for the tubular heating element is type "E". For details and other terminations, see page 3-31.

2 Arctic-Cast's unique cast aluminum shroud consists of a two-piece clamshell design with a body thickness of 1/4". The shroud inside diameter fits perfectly over the outside diameter of the cast-in finned band heater. The segments are fastened together with bolts and nuts.

A specially built-in air deflector breaks up the incoming laminar air flow from the blowers and evenly distributes it over the entire finned cross section of the cast-in band heater, insuring uniform coverage and optimizing the cooling efficiency of the cast-in aluminum heater in the extrusion process.

The shroud flange blower ports can be made square or round single port, or double port to accommodate more than one blower. The mounting hole pattern is determined by the blower.

3 Tempco offers two styles of forced air blowers.

(1) Cast aluminum housing with a round or square port mounting flange and optional air filter.

(2) Sheet metal housing with single or double port blowers.

For additional information and standard sizes of Arctic-Cast® systems and a complete selection of blowers, see pages 3-30 through 3-35.

Arctic-Cast®
the solution for improving
your process
efficiencies with
lower operating
cost.

SATISFACTION GUARANTEED!



Cast Aluminum Shrouds for Arctic-Cast™ Systems

The unique Cast Shroud used on the Arctic Cast® system is critical to the performance and cooling function of the system. The shroud is responsible for three main operational functions:

1. **Properly directs and evenly distributes the airflow from the blower across the heater body.**
2. **Minimizes the laminar airflow from the blower, which is common in non-shrouded systems, and ensures maximum BTU removal from the extrusion process by optimizing airflow and heater surface contact.**
3. **Provides safe, sturdy and effective mounting for the forced air blowers with the most simplistic and basic assembly requirements.**

The Arctic Cast® shroud is vastly superior to sheet metal wrap shrouding devices, as the cast shroud consists of two ¼" thick aluminum halves that bolt together in clamshell fashion over the special finned cast heater.

A specially designed internal deflector evenly distributes the airflow through the shroud across the heater body to ensure uniform, rapid BTU removal from the extrusion process. The flange mount blower ports are designed for industry standard blower dimensions and bolt hole patterns or to your specifications. One or two blower ports can be used, depending on application requirements.

The result is a rigid, thermally efficient shroud that is assembled with minimal time and effort. This system is durable, rugged and sturdy. Once in place it requires little or no maintenance... it performs!

Type SP—Single Port Shroud

Type SP is designed to accommodate a single forced air blower. In most air cooled applications it is typical to use one to three Type SP units in a zone, depending on dimensional and electrical requirements. The maximum recommended length for Type SP design is 18".



Type DP—Dual Port Shroud

In cases where it is advantageous to cover longer barrel lengths with a single heater, Type DP can be employed. Two appropriately positioned blower ports are used to maintain adequate and uniform airflow coverage over the heater surface area. On applications in excess of 18" in length a single blower may not provide proper airflow distribution or an adequate volume of airflow; therefore the dual port shroud is recommended.



Screw Terminal Terminations

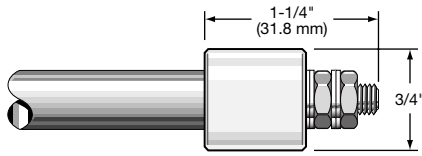

Type S

Heavy duty ceramic insulator for .430" diameter heater with 10-32 screw threads. Standard on Cast-In Heaters unless otherwise specified.

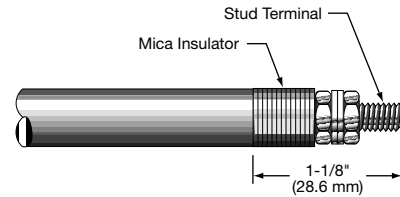

Type T

Mica insulator is the same diameter as the heating element. Available for .260", .315" and .430" diameter heaters. .260" diameter has 6-32 terminal; .315" and .430" have 10-32 terminals.

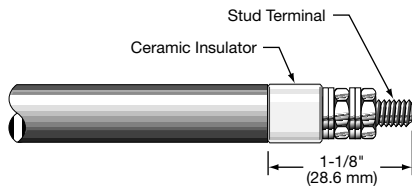

Type T7

Ceramic insulator is the same diameter as the heating element. Available for .260", .315" and .430" diameter heaters. .260" diameter has 6-32 ; .315" and .430" have 10-32 terminals.

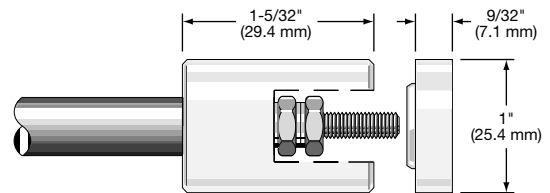

Type C4

Heavy duty ceramic insulator with terminal cover for screw terminal 10-32 thread. Available for .315" and .430" diameter heaters.

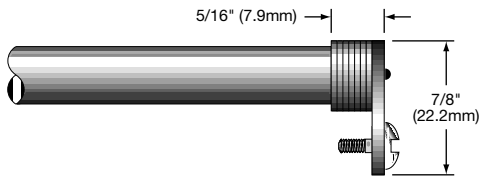

Type E

Right-angle lug welded to pin with mica washer insulators and 10-32 binding head screw. Available for .260", .315" and .430" diameter heaters.

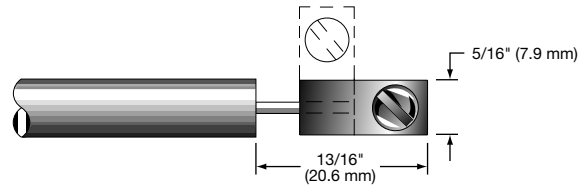

Type L & L9

Terminal lug spot welded to pin with 10-32 binding head screw. Available for .260", .315" and .430" diameter heaters. Type L represents straight; Type L9 represents 90° to pin. Specify lug orientation.

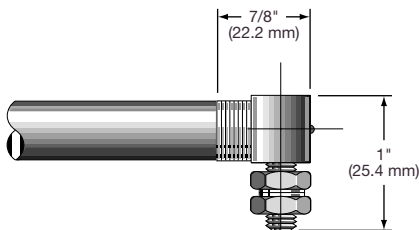

Type R

Mica washers with 90° blockhead screw terminal with 10-32 screw threads. Available for .260", .315" and .430" diameter heaters.

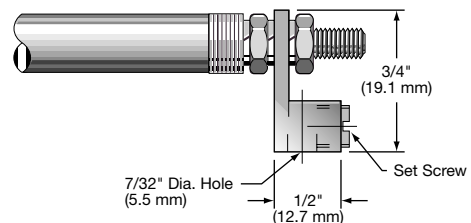

Type R2

Mica washers with blockhead and through hole for lead wire connection. Eliminates the use of ring terminals. Available for .260", .315" and .430" diameter heaters. Accepts 6-14 gauge wire.



Selecting Standard Arctic-Cast™ System Assemblies

The typical Arctic Cast System consists of: **A Cast-In Aluminum Finned Band Heater**
A Cast Aluminum Shroud
An appropriately rated Forced Air Blower



For additional information on sizing and selecting Cast-In Band Heaters for your application, see page 3-14. To order an Arctic-Cast™ system not

Page 3-29 illustrates the system complete as well as the components that make up each assembly. Envelope dimensions for the shrouds shown on page 3-33 are also provided. Pages 3-34 and 3-35 display different forced air blower styles and specifications.

shown in our Standard Sizes and Ratings, consult Tempco or send us your specifications and/or drawing.

Extruder Size	Heater I.D. in	Assy. No. Shroud & Heater	Watts Each Half	Volts Each Half	Blower Style	Replacement Components		Dimensions			Shroud Style
						Heater	Shroud	"A" in	"B" in	"L" in	
2" to 2½"	4.500	FCS01001	1620	230	3 or 4	CBH02937	ASF01006	9.000	8.500	10.750	A
	4.500	FCS01002	1500	230	9 or 10	CBH05676	ASF01052	7.750	5.375	12.250	C
	5.000	FCS01003	2000	230	9 or 10	CBH05677	ASF01053	9.000	6.313	12.438	C
	5.500	FCS01004	2750	230	1 or 2	CBH03270	ASF01001	10.000	9.125	11.000	A
	4.725	FCS01005	1400	240	1 or 2	CBH03960	ASF01015	8.188	6.299	7.402	A
	4.940	FCS01006	2250	230	8	CBH05539	ASF01046	8.940	10.625	12.000	A
	5.500	FCS01007	2100	230	3 or 4	CBH02803	ASF01002	10.000	9.125	11.000	A
	5.500	FCS01008	1700	230	3 or 4	CBH02909	ASF01007	10.000	9.125	8.500	A
	5.500	FCS01009	4150	230	1 or 2	CBH03664	ASF01009	10.000	10.125	13.250	A
	5.500	FCS01010	1725	230	1 or 2	CBH04193	ASF01020	9.000	7.063	9.000	A
5.750	FCS01011	2700	230		CBH05404	ASF01037	10.250	11.250	13.000	A	
3½"	6.250	FCS01012	1400	260	1 or 2	CBH05153	ASF01029	10.250	7.688	8.250	A
	6.250	FCS01013	5000	480	3 or 5	CBH05648	ASF01051	10.500	10.125	15.000	A
	6.500	FCS01014	3600	230	3 or 4	CBH02802	ASF01003	11.000	9.750	17.500	A
	6.500	FCS01015	3000	240	1 or 2	CBH03699	ASF01010	10.500	9.375	12.000	A
	6.500	FCS01016	3000	240	1 or 2	CBH03700	ASF01011	10.500	10.125	15.000	A
	6.500	FCS01017	3600	230	1 or 2	CBH02802	ASF01014	11.000	9.750	17.500	A
	6.500	FCS01018	3750	230		CBH04953	ASF01026	10.500	10.500	13.000	A
	6.500	FCS01019	3600	230	1 or 2	CBH02802	ASF01050	11.000	9.750	17.500	A
	6.625	FCS01020	4625	480	1 or 2	CBH03606	ASF01008	11.000	9.750	17.500	A
	6.750	FCS01021	4800	230		CBH05405	ASF01038	11.250	11.250	16.000	A
4"	7.500	FCS01022	6000	240	(2) 1 or (2) 2	CBH04815	ASF01025	11.500	10.000	21.000	B
	7.500	FCS01023	4500	240	1 or 2	CBH05092	ASF01028	11.500	10.000	18.000	A
	7.500	FCS01024	3500	230		CBH05395	ASF01035	12.000	11.250	17.000	A
	7.500	FCS01025	6000	230		CBH05396	ASF01036	12.000	11.250	22.000	A
	7.500	FCS01026	4170	230		CBH05397	ASF01036	12.000	11.250	22.000	A
	7.500	FCS01027	4170	230		CBH05573	ASF01047	12.000	12.250	22.000	A
	7.500	FCS01028	6000	230		CBH05575	ASF01047	12.000	12.250	22.000	A
	7.500	FCS01029	3500	230		CBH05574	ASF01048	12.000	12.250	18.000	A
	7.625	FCS01030	5500	230	1 or 2	CBH04732	ASF01024	11.500	8.375	14.438	A
	8.000	FCS01031	3250	230	5 or 6	CBH03738	ASF01013	12.000	8.438	14.000	A
	8.250	FCS01032	3850	230	1 or 2	CBH03994	ASF01019	12.250	9.000	13.000	A
	8.250	FCS01033	7000	190		CBH04426	ASF01021	12.250	11.430	16.000	A
	8.500	FCS01034	5750	240	7	CBH05234	ASF01030	12.500	10.500	20.000	B
	8.250	FCS01035	7000	480	3 or 4	CBH04629	ASF01012	13.000	10.500	19.000	A
	8.500	FCS01036	7200	240	3 or 4	CBH03711	ASF01012	13.000	10.500	19.000	A
	8.660	FCS01037	3000	230	3 or 4	CBH03508	ASF01004	13.125	10.875	8.000	A
8.660	FCS01038	3000	230	3 or 4 (2)	CBH03508	ASF01005	13.125	10.875	16.000	A	
6"	9.313	FCS01039	7500	230		CBH05326	ASF01033	13.813	14.500	23.500	A
	9.313	FCS01040	9900	230		CBH05327	ASF01033	13.813	14.500	23.500	A
	9.313	FCS01041	7500	230		CBH05328	ASF01034	13.813	14.500	28.500	A
	9.313	FCS01042	7500	230		CBH05445	ASF01039	13.813	14.500	23.500	A
	9.313	FCS01043	9900	230		CBH05446	ASF01039	13.813	14.500	23.500	A
	9.313	FCS01044	7500	230		CBH05447	ASF01040	13.813	14.500	28.500	A
	9.313	FCS01045	9900	460		CBH05513	ASF01042	13.813	14.500	28.500	A
	9.313	FCS01046	7500	460		CBH05515	ASF01043	13.813	14.500	23.500	A
	9.750	FCS01047	9000	110		CBH04428	ASF01022	13.750	12.125	22.000	A
	9.750	FCS01048	9000	190		CBH04427	ASF01022	13.750	12.125	22.000	A
	9.750	FCS01049	5700	480	1 or 2	CBH05530	ASF01044	13.750	11.125	15.500	A
	9.750	FCS01050	5700	480	1 or 2	CBH05531	ASF01045	13.750	11.125	21.500	A
	9.750	FCS01051	5250	240	3 or 4	CBH05619	ASF01049	13.750	12.125	22.000	A
	9.750	FCS01052	7500	480		CBH05684	ASF01054	13.750	11.125	19.000	A
9.750	FCS01053	7500	480		CBH05685	ASF01055	13.750	11.125	19.000	A	
10.000	FCS01054	7850	240	1 or 2	CBH04996	ASF01027	14.000	11.250	24.500	B	
10.630	FCS01055	3450	240		CBH05238 & CBH05239	ASF01031	16.875	14.065	29.000	B	
8"	11.000	FCS01056	11000	110		CBH04429	ASF01023	15.000	12.750	22.000	A
	13.000	FCS01057	6750	480	1 or 2	CBH05289	ASF01032	17.000	12.000	14.000	A



Shroud Style A

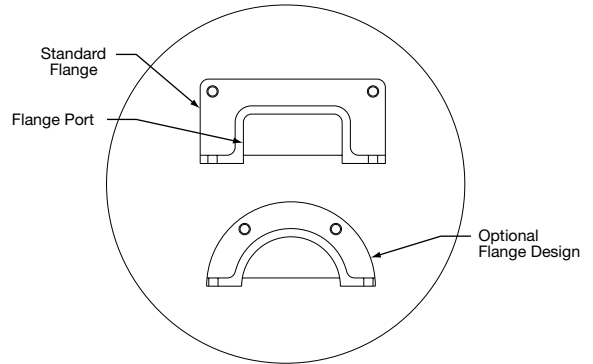
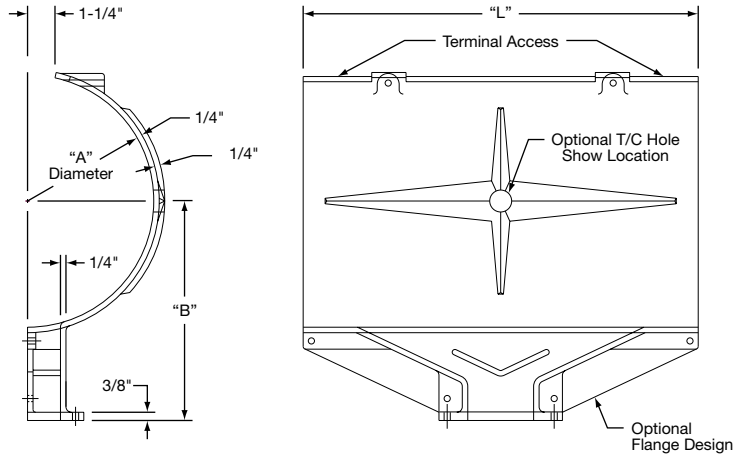

Please provide mounting hole specifications if using other than Tempco standard.

Shroud Style B

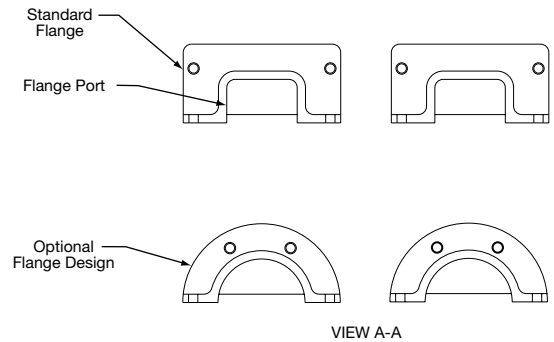
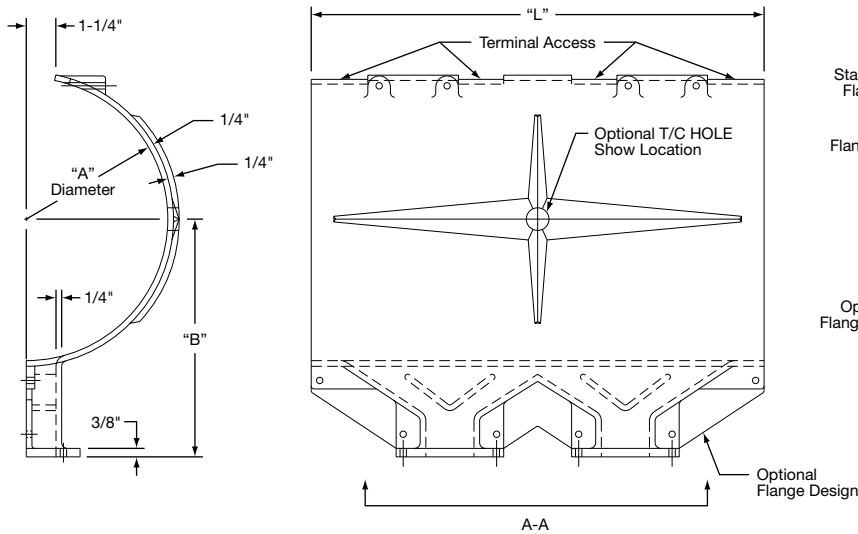

Please provide mounting hole specifications if using other than Tempco standard.

Shroud Style C

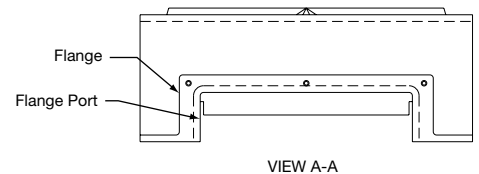
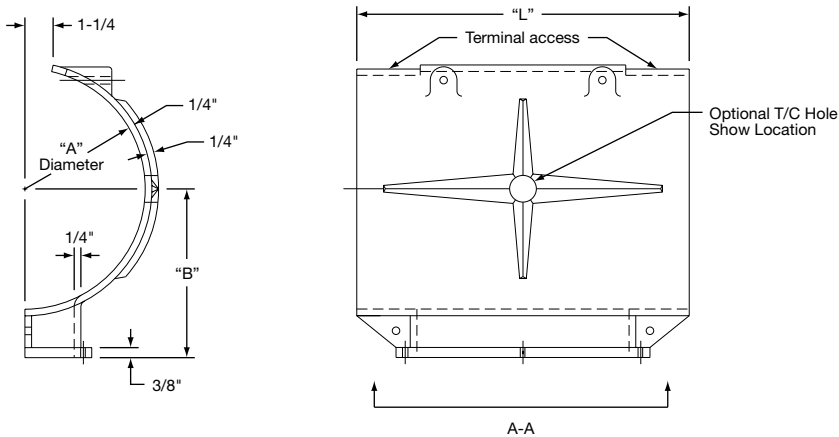

Please provide mounting hole specifications if using other than Tempco standard.



Forced Air Blowers for Air Cooled Heating Systems

Forced Air Blowers are used to cool Tempco Arctic-Cast™, Checkmate™ and conventional air cooled extrusion systems. Ambient air enters the shroud at the flanged port and circulates through the shroud across the body of the heater, exiting the shroud opposite the blower.

Tempco Forced Air Blowers feature either Cast Aluminum or sheet metal housings and steel impellers. The fan housing is mounted directly to the motor. Quiet operation and the high volume capacity make these units ideally suited for use in extrusion cooling processes. Tempco Forced Air Blowers are available in several CFM ratings, 120 or 230 volts and flange mount sizes. Adapter flange plates and air intake filters to keep motor clean and free of debris are available upon request—consult Tempco with your requirements.

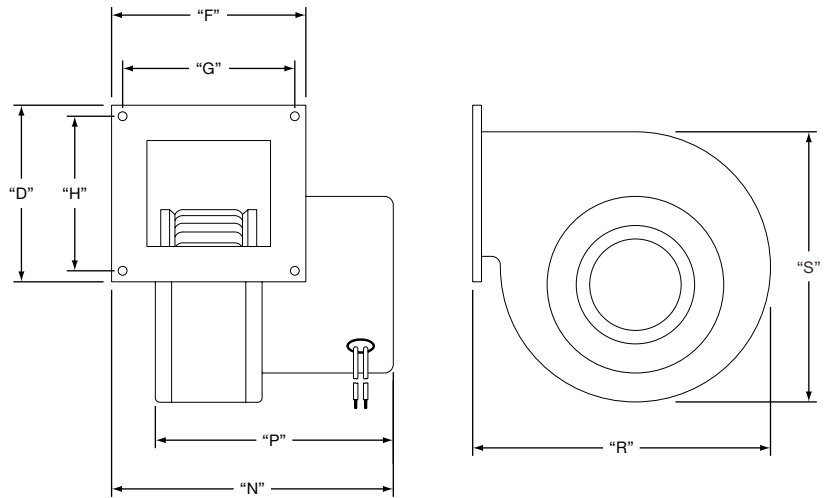

Standard Model Single Port Blower with Sheet Metal Housing

Blower Style	Part Number	"D"	"F"	"G"	"H"	"N"	"P"	"R"	"S"	RPM	CFM	Amps	Volts
1	MTR-101-101	5.000	5.500	4.875	4.375	8.031	7.375	8.843	9.875	1610	265	.93	230
2	MTR-101-102	5.000	5.500	4.875	4.375	8.312	7.656	8.843	9.875	1610	265	1.86	115
3	MTR-101-103	5.625	6.625	6.000	5.000	10.187	9.500	10.313	11.125	1570	495	3.25	115
4	MTR-101-105	5.625	6.625	6.000	5.000	10.187	9.500	10.313	11.125	1570	495	1.70	230
5	MTR-101-106	5.625	5.063	4.500	5.000	8.594	8.000	10.313	11.125	1585	350	2.90	115
6	MTR-101-107	5.625	5.063	4.500	5.000	8.594	8.000	10.313	11.125	1585	350	1.45	230

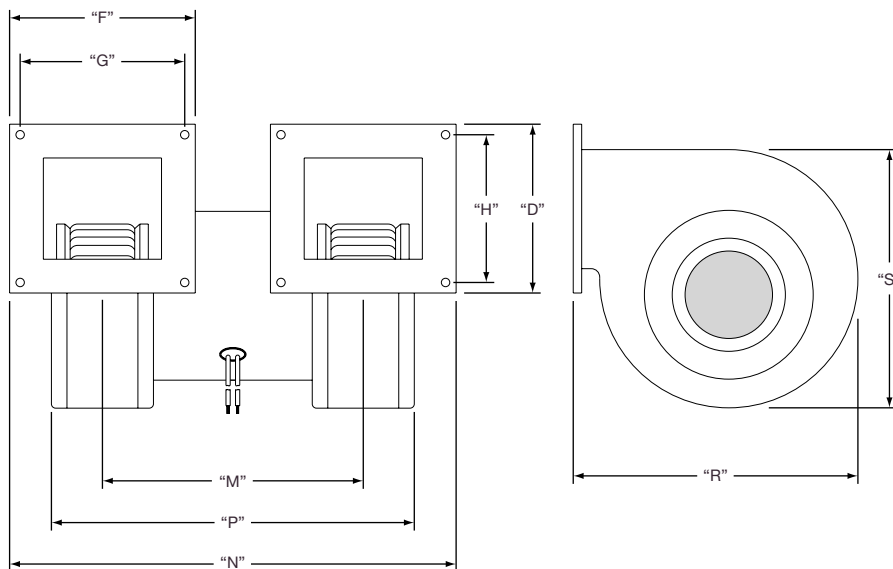

Standard Model Double Port Blower with Sheet Metal Housing

Blower Style	Part Number	"D"	"F"	"G"	"H"	"M"	"N"	"P"	"R"	"S"	RPM	CFM	Amps	Volts
7	MTR-101-104	4.750	4.750	4.125	1.469	7.750	12.500	11.125	8.063	8.375	1320	320	1.27	115

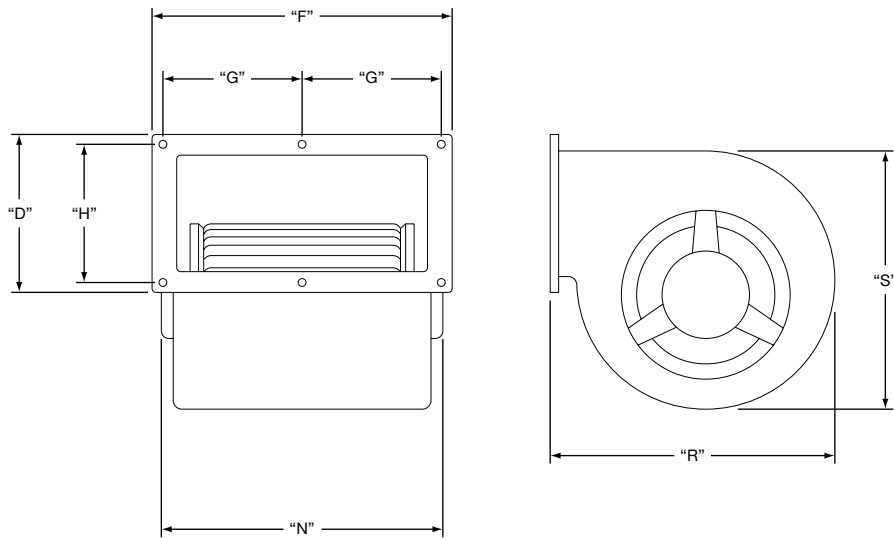

Single Port Blower with Large Volume Port and Sheet Metal Housing

Blower Style	Part Number	"D"	"F"	"G"	"H"	"N"	"R"	"S"	RPM	CFM	Amps	Volts
9	MTR-101-108	5.000	9.688	4.406	4.375	9.250	8.813	9.875	1530	465	2.90	115
10	MTR-101-109	5.000	9.688	4.406	4.375	9.438	8.813	9.875	1530	465	1.30	230

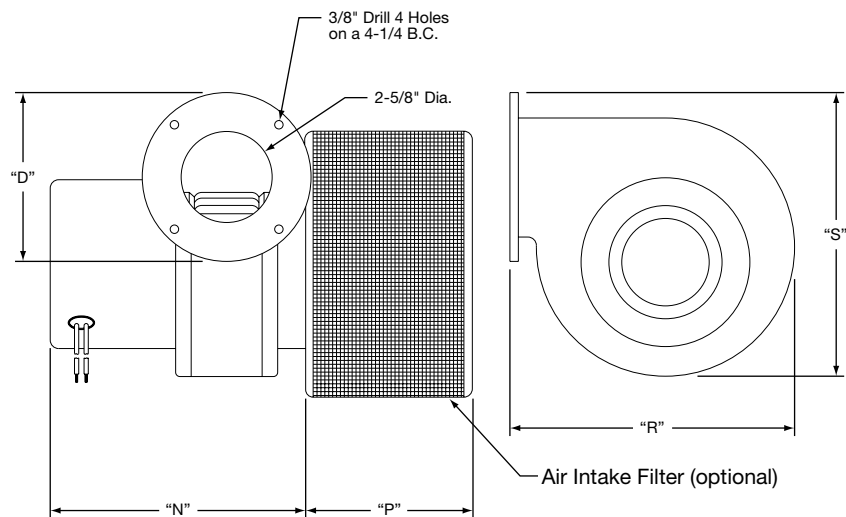

Single Port Blower with Cast Aluminum Housing, Round Flange and Optional Air Intake Filter

Blower Style	Part Number	"D"	"N"	"P"	"R"	"S"	RPM	CFM	Amps	Volts
8	MTR-101-110	4.875	8.625	5.500	7.438	7.750	3200	180	1.6	120



Note: All CFM Values are with free inlet and discharge and 0" Static Pressure. All Dimensions are in inches.



Checkmate™ Air Cooled Heating Systems for Extrusion

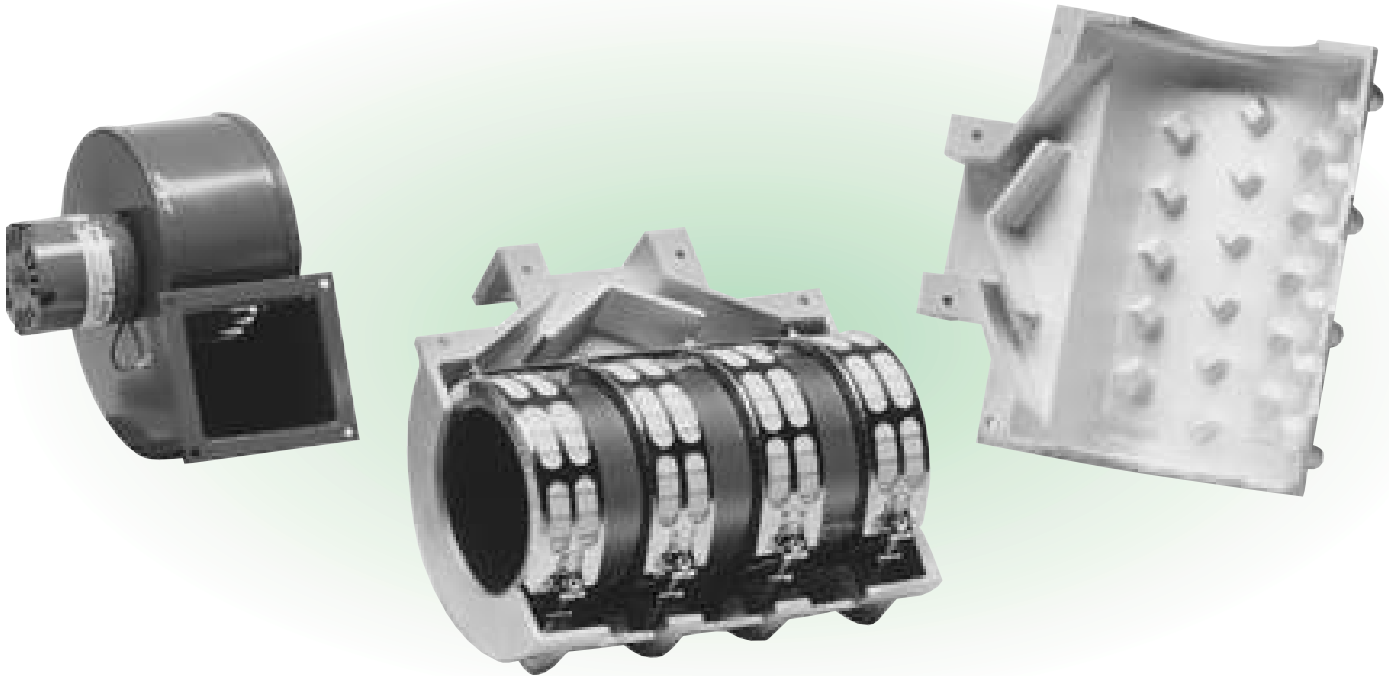

Ceramic Band Heaters featuring Cast Aluminum Shroud and Blower Assembly

The Checkmate™ System was originally developed to provide another means of heating and cooling high temperature extrusion processes. Typically, Cast-In bronze or brass units are used in applications where heater temperatures can be in excess of 700°F (371°C). Since Cast-In bronze or brass heaters are approximately three times the weight of their aluminum counterparts, they are generally considered to be difficult to work with on installation and are expensive.

In response to this challenge, Tempco's engineers have developed the Checkmate™ System, which provides extrusion processes with high temperature heating and cooling capabilities featuring a unique construction of a low mass, non thermally insulated ceramic band heater and highly efficient cast aluminum shroud.

Forced Air Blowers are used to cool Tempco's Checkmate™ air cooled heating systems. The ambient airflow enters the shroud, circulates around the ceramic heater and barrel, removes the heat from the heater and the process and exits the shroud opposite the entrance port.

FORCED AIR BLOWERS are available in sizes and ratings ranging from 265 CFM to 495 CFM free air.

See pages 3-34 and 3-35 for blowers.

Construction Characteristics

The Ceramic Band is manufactured in two distinct styles:

1. Full Coverage (FCC) type, which has higher watt density capabilities but lesser cooling capabilities.
2. Rib Cage (RCC) type, which orients the ceramic insulators and resistance coils in a columnar fashion.

The Rib Cage design offers faster cooling response time as it allows the forced air from the blower to pass directly onto the barrel itself, thereby maximizing BTU removal efficiency. The Rib Cage design will have less watt density capability than the Full Coverage type since there is less area to accommodate resistance coils. Both styles use a perforated outer shell to support the ceramic insulators and neither style incorporates thermal insulation, which would minimize cooling efficiency.

The Cast Aluminum shroud is designed with precisely arranged Aluminum nodules on the inside diameter of the shroud to break up the laminar airflow from the forced air blower. This results in an effective dispersion of the airflow directly onto the heater and the barrel itself. The shroud is a two piece clamshell design featuring a sturdy flange mount arrangement customized to accept the blower motor that best suits your extrusion process needs.

Field data on the Checkmate™ System have proven it to be very thermally efficient on high temperature applications and equally effective in standard plastics processing, making the system an excellent choice for machine retrofits. Consult Tempco with your specific application requirements.

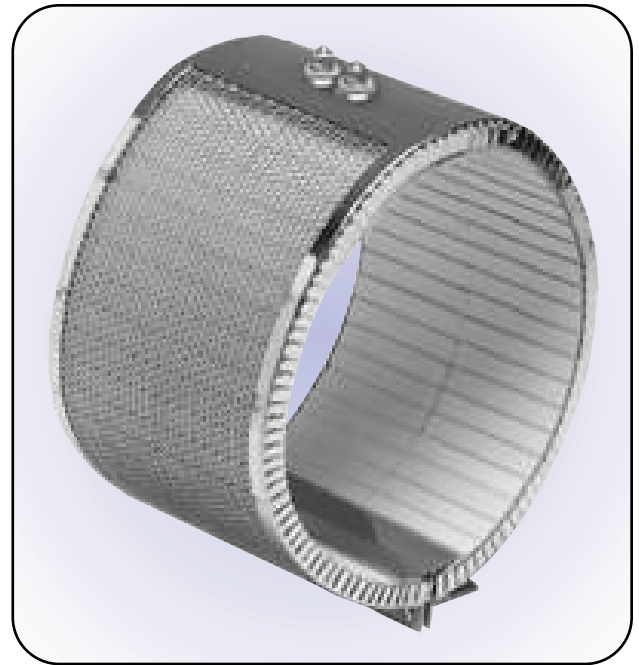
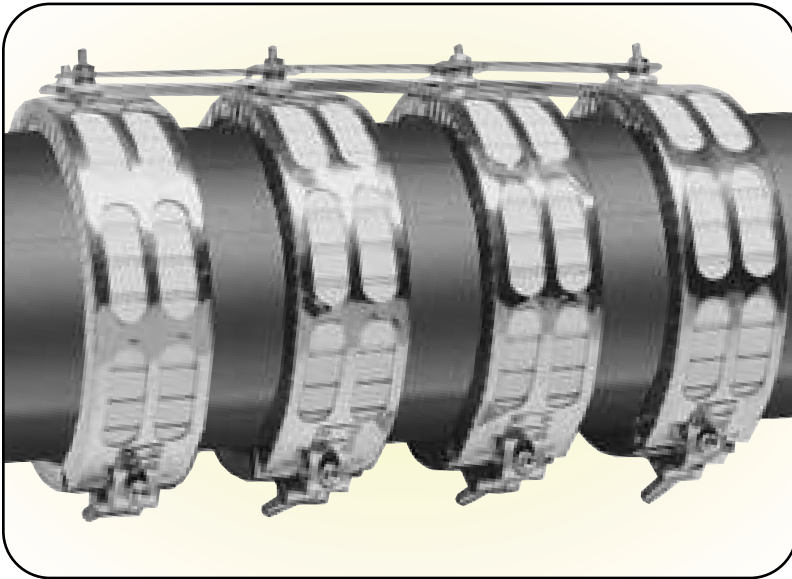

Type RCC – Partial Coverage Band

The Rib Cage style ceramic band features columnar arrangement of the heater insulators to yield large open areas. This allows the forced air to make direct contact with the extruder barrel to maximize cooling capabilities. The watt density should be limited to 25 watts/in² and can be designed for single, dual or three phase voltage.

Type FCC Full Coverage Band

The Full Coverage Ceramic Band Heater provides complete coverage of the area to be heated. This design is capable of higher watt densities—up to 50 watts/in² and can be made in single, dual or three phase voltage.

DESIGN STANDARDS

MECHANICAL

Ceramic Band Heaters Type FCC and Type RCC

Standard Width Increments:	½"
Maximum Width:	Depends on ratio of diameter to width
Minimum Width:	1½"
Standard Gap:	½" ± 1/8"
Maximum Diameter:	18"

Cast Shroud:

Nominal O.D.:	Add 3" (Ref.) to heater I.D.
Minimum Width:	Band heater width +1"
Width Tolerance:	±¼"
Flange Mount for Blower:	Specify blower size and bolt hole pattern

ELECTRICAL

Resistance Tolerance:	+10%, -5%
Wattage Tolerance:	+5%, -10%
Maximum Voltage (when applicable):	480, Single or 3 phase
Maximum Amperage:	25 Amps/circuit
Maximum Watt Density:	FCC 50 watts/in ² RCC 25 watts/in ²
Maximum Temperature:	900°F (482°C)

How To Order

All Checkmate™ Systems are made to customer specifications. Consult Tempco with your requirements.



“L” Shaped Bronze, Brass or Aluminum Cast-In Heaters for Square and Rectangular Extruder Barrels

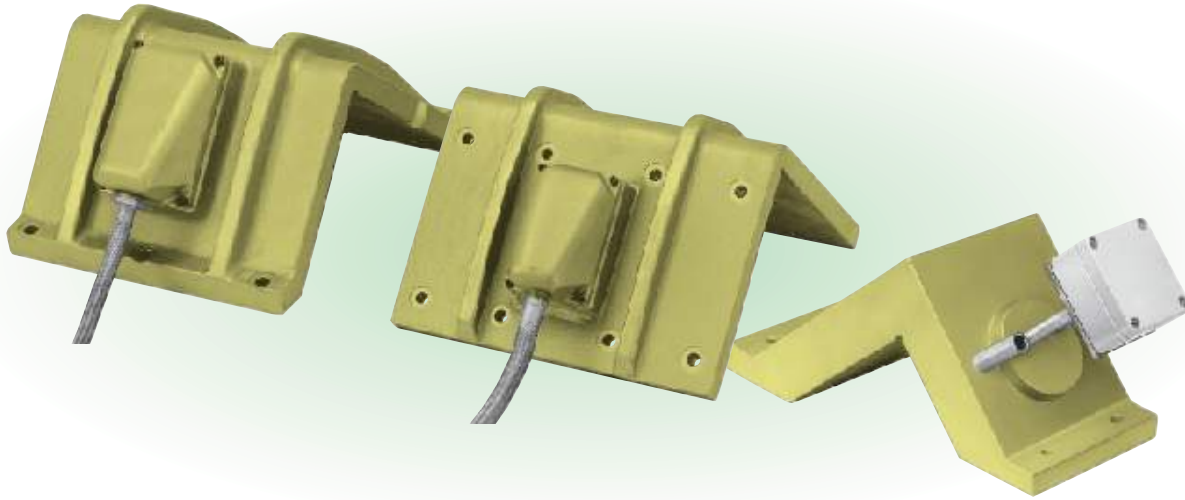

Cast-In Heaters that provide High Temperature and Maximum Processing Capabilities

The “L” Shaped Cast-In Heaters are typically used on square and rectangular twin screw extruder barrels in compounding and plastic resin manufacturing applications. Due to high shear rates, which are common in this process, extreme operating temperatures and high watt densities are frequently encountered. For these reasons Tempco manufactures “L” shaped heaters in bronze or brass alloys, which are capable of withstanding high temperatures at higher watt densities.

In the case of applications requiring lower temperatures and lower watt densities, aluminum alloys can be used. Aluminum castings are desirable as they have greater thermal conductivity and weigh substantially less than their bronze or brass counterparts, allowing for greater ease of installation.

For mounting purposes the heaters can be designed with 45° flanged ear extensions that are bolted together and drawn together, or can be made with through holes machined into the casting body to bolt directly onto the barrel itself. Thermocouple and transducer holes or other special features can be accommodated as well.

To enhance the cooling capabilities, or to be used in place of integral feed screw cooling, “L” shaped heaters can be manufactured with cast-in cooling tubes to satisfy liquid cooling requirements. This feature allows processors the ease of changing a single unit at a time, thus representing a far less time-consuming and less expensive alternative should a cooling line become clogged or severely restricted.

Standard “L” Shaped Cast-In design features:

- * **Cast-In Bronze or Brass Alloys for high temperature, high shear applications.**
- * **Manufactured in sets consisting of two corresponding halves.**
- * **Flange bolt clamping arrangement or through holes in the heater body to allow bolt mounting directly to the barrel.**
- * **High precision machining of the inner contact surface of the heater, yielding exceptional heat transfer to the process.**
- * **Moisture resistant terminal housing which is available in a variety of different styles and mounting arrangements.**

Enhanced Features

To aid processors in reducing maintenance downtime, Tempco has introduced several optional construction features to the basic “L” shaped design.

- * **Cast-In Aluminum Alloys for applications requiring lower temperatures and less watt density.**
- * **$\frac{3}{8}$ " or $\frac{1}{2}$ " O.D. cooling tubes for liquid cooling.**
- * **Non-Exposed cooling tubes (Type RC—See page 3-7). Eliminates cracked and broken cooling tubes.**

- * **Choice of terminal protection housings.**
- * **Elevated temperature terminations and enclosures. Prevents premature heater failure due to accelerated corrosion or oxidation of terminals caused by high heater surface temperature. See page 3-40 for details on how to order.**



All of the options listed above are design enhancements that will provide value-added benefits to the basic “L” shape configuration, thereby extending the life and performance of your Cast-In Heaters.



Standard Sizes and Ratings

These sizes and ratings are among the most commonly used. They will provide the shortest lead times.

"L" Shaped Bronze, Brass or Aluminum Cast-In Heaters are sold as sets or as individual units. They are normally supplied with a moisture resistant junction box. Also available with explosion resistant or cast-on junction box, fitted with convoluted wire braided hose and high temperature lead wire. If required, specify. For additional terminations, see pages 3-10 and 3-11.

Long Leg (in)	Short Leg (in)	Width in	Thickness in	Watts	Volts	Special Features	Part Number
2.500	1.550	1.750	0.500	300	120	(1) 1/2" long slot, R1, Hubbel® plug, Aluminum	CBH04036
2.500	1.550	1.750	0.500	300	120	(1) 1/8" NPT hole, (1) 1/2" long slot, Bronze	CBH04103
3.460	2.680	4.330	1.181	500	220	MPR terminal box, (1) 25 mm dia. hole, (4) 9 mm dia. holes, Aluminum	CBH04926
3.460	2.680	4.330	1.181	500	220	MPR terminal box, (1) 25 mm dia. hole, (4) 9 mm dia. holes, Aluminum	CBH04922
3.460	2.760	4.330	1.181	500	220	MPR terminal, (1) 25 mm dia. hole, (8) 9 mm dia. holes, Aluminum	CBH04929
3.937	3.465	4.331	1.181	500	230	MPR terminal, 3/8" NPT RA elbow C/T, Brass	CBH04045
4.173	3.071	4.310	1.000	900	240	Cast terminal box, (2) 1/2" dia. holes, (2) 1/2" dia. cutouts, Bronze	CBH01617
4.173	3.346	4.921	1.575	2000	230	MPR, (1) 25 mm dia. hole, Brass	CBH04295
4.724	3.248	4.921	1.575	1500	230	MPR terminal box, (1) 25 mm dia. hole, Brass	CBH04290
4.823	3.346	4.921	1.575	2000	230	MPR terminal box, (1) 25 mm dia. hole, Brass	CBH04294
6.000	4.449	6.417	1.000	2000	240	Cast terminal box, (4) 1/2" dia. holes, (2) 1" long cutouts, Bronze	CBH01618
6.140	4.311	7.480	0.750	2500	240	Cast terminal box, (5) 1/2" dia. holes, (2) 1/2" dia. cutouts, Bronze	CBH01971
6.180	4.215	6.690	1.000	3000	240	Cast terminal box, (5) 3/16" dia. holes, (2) 1" dia. cutouts, Bronze	CBH02140
6.188	4.313	1.000	1.000	1500	240	Cast terminal box, (1) 1" dia. hole, (4) 1/4" dia. holes, Bronze	CBH01619
7.756	11.693	14.961	1.970	4500	460	MPR terminal box, (6) .394" dia. holes, Aluminum	CBH05011
7.813	5.188	10.625	1.000	5250	480	Cast terminal box, (8) 3/16" dia. holes, Bronze	CBH03042
7.830	5.220	10.63	0.980	3500	480	Cast terminal box, (8) 3/16" dia. holes, Bronze	CBH02114
7.874	6.102	10.394	1.000	4200	480	Cast terminal box, (6) 3/16" dia. holes, Bronze	CBH01692
7.874	6.102	10.394	1.000	4200	480	Cast terminal box, (6) 3/16" dia. holes, Bronze	CBH01839
8.500	6.140	2.750	0.750	1200	240	Cast terminal cover, (1) 1" dia. hole, (2) 1/2" dia. holes, Bronze	CBH01725
8.500	6.140	7.480	0.750	5250	240	Cast terminal box, (6) 1/2" dia. holes, (2) 7/8" dia. holes, Bronze	CBH02124
8.890	5.945	6.420	1.000	3000	240	Cast terminal box, (6) 1/2" dia. holes, (1) 1" dia. hole, Bronze	CBH01550
9.055	4.684	2.362	0.591	750	240	13" Cable, 18" leads, (5) .413" dia. holes, Aluminum	CBH04591
9.134	6.000	7.480	1.000	3500	240	Cast terminal box, (4) 1/2" dia. holes, Bronze	CBH05352
9.173	6.181	10.630	1.772	5000	230	MPR terminal box, (8) .472" dia. holes, (1) 1" dia. hole, Brass	CBH03940
9.449	7.756	14.330	1.102	6800	277	Cast terminal box, 3 phase, (8) 3/16" dia. holes, Bronze	CBH01667
9.449	7.756	14.330	1.102	6800	575	Cast terminal box, 3 phase, (4) 1/2" dia. holes, (4) 3/16" dia. holes, Bronze	CBH01709
10.563	7.813	10.625	1.000	8800	480	Cast terminal box, 3 phase, (8) 3/16" dia. holes, Bronze	CBH03041
10.590	7.830	10.630	1.000	5500	480	Cast terminal box, 3 phase, (8) 3/16" dia. holes, Bronze	CBH02113
10.830	4.684	2.362	0.591	870	240	MPR terminal box, (5) .413" dia. holes, Aluminum	CBH04594
11.690	7.756	14.960	1.968	N/A	N/A	(12) .393" dia. holes, (1) .984" dia. hole, Aluminum	CBH05013
11.690	7.760	14.960	1.969	9000	460	MPR terminal box, (10) .393" dia. holes, Aluminum	CBH05014
12.188	7.875	10.375	1.000	8100	480	Cast terminal box, (6) 3/16" dia. holes, Bronze	CBH04408
12.205	7.875	4.134	1.000	3000	240	Cast terminal box, (4) 3/16" dia. holes, (1) 7/8" dia. cutout, Bronze	CBH01756
12.205	7.875	10.394	1.000	6260	480	Cast terminal box, (6) 3/16" dia. holes, Bronze	CBH02144
15.712	13.000	9.250	1.250	5500	220	(6) 1/2" dia. holes, (1) 7/8" hole, Bronze	CBH05037
18.110	9.169	4.530	0.591	3030	240	(10) .493" dia. holes, 20" cable, 27" leads, Aluminum	CBH04593
18.110	9.169	4.530	0.591	3030	240	MPR terminal box, (10) .430" dia. holes, Aluminum	CBH04596
6.188	4.219	4.313	1.000	1500	240	Cast terminal box, (4) 1/2" dia. holes, (1) 1" dia. hole, Bronze	CBH05816
3.500	2.500	3.500	0.875	500	240	Cast terminal box, (3) .397" dia. holes, (1) 5/8" dia. cutout, Bronze	CBH05817
3.500	2.500	3.500	0.875	500	240	Cast terminal box, (3) .397" dia. holes, Bronze	CBH05818
3.500	2.500	7.000	0.875	1000	240	Cast terminal box, (6) .397" dia. holes, Bronze	CBH05819

Abbreviations

E/H = Each Half	C/T = Cooling tubes
EP = Explosion Resistant Terminal Housing	CW = Single Set of Cooling Tubes
MR = Moisture Resistant Terminal Housing	CWW = Dual Set of Cooling Tubes
MPR = Moisture Proof Die Cast Aluminum Box	RC = Non-Exposed Cooling Tubes/Recessed NPT Fittings



"L" Shaped Cast-In Heaters—45° Flange Mount Style

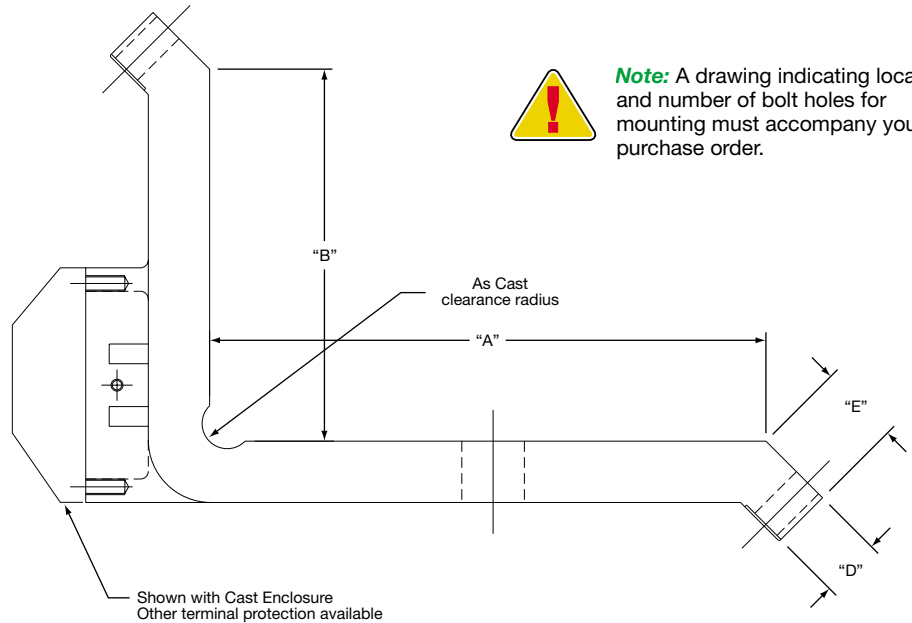
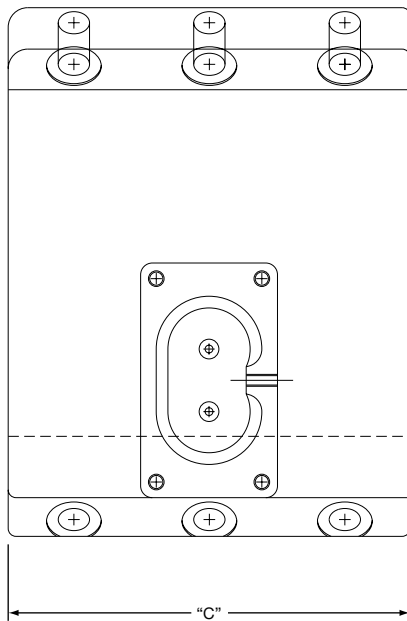

Variable Dimensions

"A" _____ "B" _____ "C" _____
 "D" _____ "E" _____

Material Specifications

Aluminum Bronze Brass

Electrical Specifications

Watts each piece _____ Volts each piece _____ Phase _____

Clamping Style

Bolt Clamp Other

Cooling Tube Sizes

¼" O.D. SS ⅜" O.D. SS ½" O.D. SS Optional Incoloy® (½" only) Dual Cooling Tubes

Cooling Tube Fittings

Non-exposed ⅜" NPTF "HS" Hi-Seal Fitting "RA" 90° Copper Elbow
 Non-exposed ½" NPTF "BF" High Pressure "RT" 90° Threaded Elbow
 "FF" Flared Seal "R3" Straight Threaded

Termination Style

"S" Post Terminals "T7" Post Terminals "T" Post Terminals
 "R1" Armor Cable Leads "E" Right Angle Lugs

Terminal Protection Box

"C2" Standard Cast on box as shown "MP" Moisture Resistant
 "EP" Explosion Resistant "MR1" Rigid Moisture Resistant Box
 "MPR" Moisture Resistant Box "P2" High Temperature Quick Disconnect

Finish

Machined or As Cast. *Indicate surfaces to be machined.*

Special Cast-In Features

Holes, Cutouts, Slots, Bevels, Mounting Studs, Stand-Offs and Taper Angles.
For special features a detailed drawing is required.

How To Order

To process your order or quotation, please specify the following information.



"L" Shaped Cast-In Heaters Bolt to Barrel Style

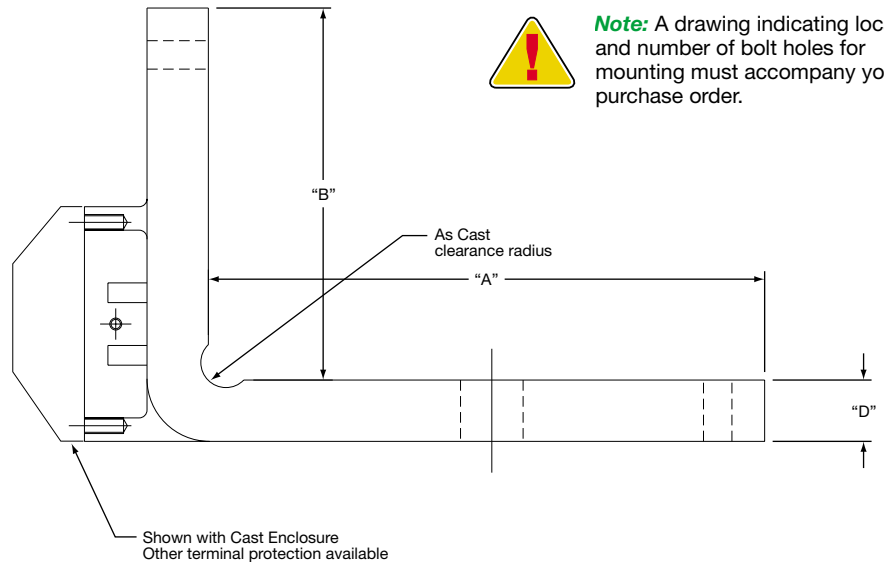
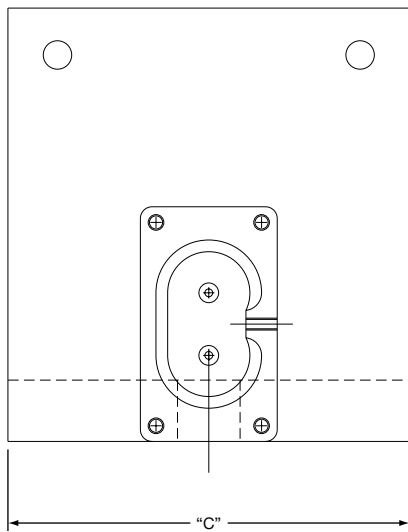

Note: A drawing indicating location and number of bolt holes for mounting must accompany your purchase order.

How To Order

To process your order or quotation, please specify the following information.

Variable Dimensions

"A" _____ "B" _____ "C" _____
"D" _____

Material Specifications

Aluminum Bronze Brass

Electrical Specifications

Watts each piece _____ Volts each piece _____ Phase _____

Clamping Style

Bolt Clamp Other

Cooling Tube Sizes

1/4" O.D. SS 3/8" O.D. SS 1/2" O.D. SS Optional Incoloy® (1/2" only) Dual Cooling Tubes

Cooling Tube Fittings

Non-exposed 3/8" NPTF "HS" Hi-Seal Fitting "RA" 90° Copper Elbow
 Non-exposed 1/2" NPTF "BF" High Pressure "RT" 90° Threaded Elbow
 "FF" Flared Seal "R3" Straight Threaded

Termination Style

"S" Post Terminals "T7" Post Terminals "T" Mica Washers
 "R1" Armor Cable Leads "E" Right-Angle Lugs

Terminal Protection Box

"C2" Standard Cast on box as shown "MP" Moisture Resistant
 "EP" Explosion Resistant "MR1" Rigid Moisture Resistant Box
 "MPR" Moisture Resistant Box "P2" High Temperature Quick Disconnect

Finish

Machined or As Cast. *Indicate surfaces to be machined.*

Special Cast-In Features

Holes, Cutouts, Slots, Bevels, Mounting Studs, Stand-Offs and Taper Angles.
For special features a detailed drawing is required.



Cast-In Aluminum Platen Heaters for Plastics Processing Equipment

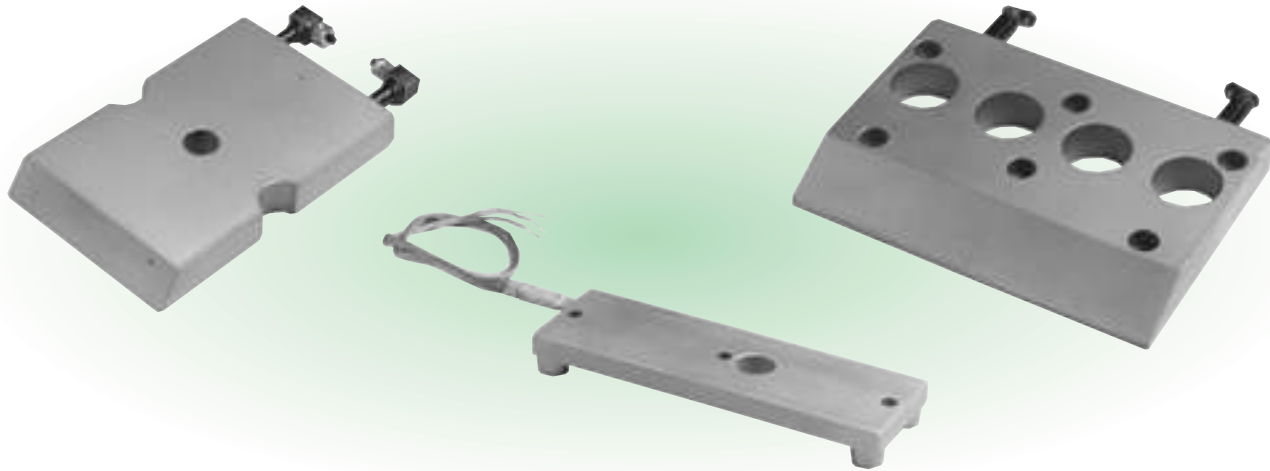

Tempco Cast-In Platen Heaters are widely accepted as the industry standard for heating critical, temperature-sensitive plastics processing downstream equipment such as:

- **Sheet dies**
- **Plastic molds**
- **Rubber molds**
- **Cast film dies**
- **Calendering dies**
- **Plastic welding equipment**
- **Screen changer equipment**

Typically, plastics die applications are highly temperature sensitive and require extreme heater uniformity and reliability.

Tempco Cast-In Aluminum Platen Heaters are a logical choice to satisfy these critical application parameters, as the aluminum alloy has excellent thermal conductivity and a highly reliable, computer designed heating element which provides good contamination resistance. Optional cooling tubes can be cast-in to more precisely modulate the temperature of your process. The result is a highly efficient, uniform heater which, if used properly, can be expected to provide years of trouble-free service.

Cast-In Platen Heaters are generally manufactured in aluminum but can also be made in bronze or brass alloys to meet higher temperature processing requirements. For high volume requirements, the permanent mold process can be used to achieve the most effective economies of scale as well as yielding the best cosmetic appeal. To service customers with lesser volume orders, Tempco's high quality no-bake sand mold process will be used, which assures excellent part quality and employs economical tooling.

Tempco's modern CNC equipped machine shop and our team of professionals will machine finish the Cast-In Heater to your exact specifications.

The Standard Cast-In Platen design features and options include:

- * **Computer designed, precisely formed tubular heating element, optimizing the heat transfer pattern.**
- * **A variety of termination options including terminal enclosure housings.**
- * **Optional $\frac{1}{4}$ " , $\frac{3}{8}$ " , or $\frac{1}{2}$ " cooling tubes cast into the platen for liquid cool function.**
- * **A variety of shapes and sizes made to your specifications.**
- * **Through-holes, tapped holes or cutouts to facilitate mounting or obstructions.**
- * **Precision machining of one or all surfaces of casting. Specify your individual requirements.**



Cast-In Platen Heaters are made to customer specifications. Please review our "Standard Sizes and Ratings" data along with our "How To Order" information to determine the heater best suited to your needs. Tempco also offers numerous sizes and styles off the shelf for immediate delivery.

For further information on platen heaters consult our Section "Cast-In Heaters for Commercial, Industrial and Scientific Applications" located on page 3-50.



Typical Heater Terminal and Cooling Tube Exit Locations

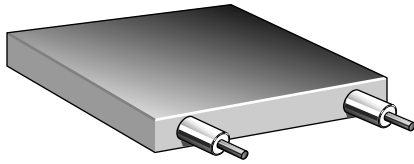

Type TE1

Elements exiting through the thickness toward the ends of the width or length.

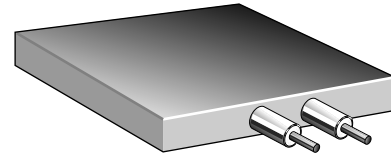

Type TE2

Elements exiting through the thickness toward the center of the width or length.

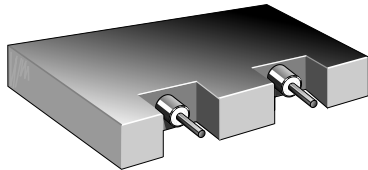

Type TE3

Elements exiting through the thickness and recesses to protect the screw terminal from mechanical damage. Can be located toward the end or center.

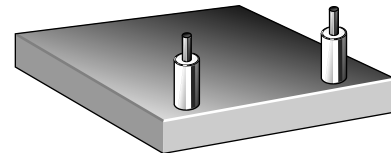

Type TE4

Elements exiting toward the ends of the width or length through the top surface.

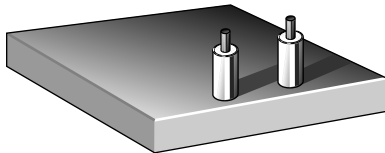

Type TE5

Elements exiting at the end and toward the center of the width or length through the top surface.

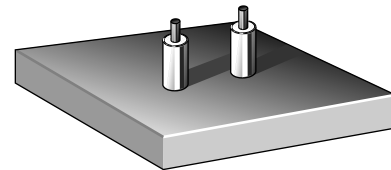

Type TE6

Elements exiting toward the center of the length and width and through the top surface.

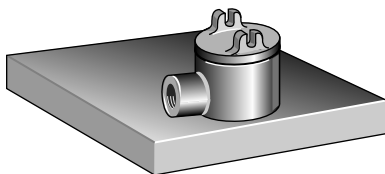

Type EP

Explosion and/or moisture resistant box.

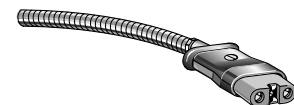

Optional Plug Assembly Shown



Type P1

Quick-disconnect cup assembly mounted directly to casting provides a fast and safe means to apply power to the Cast-In heating element. Available for .260", .315" and .430" diameter elements. Rated 250V max., 15 Amp max.



Typical Heater Terminal and Cooling Tube Exit Locations

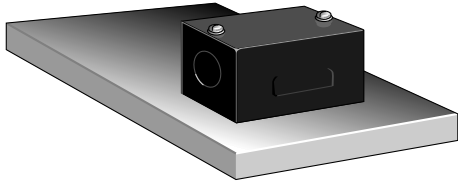

Type C2

Sheet metal terminal box with $\frac{5}{8}$ " knockouts.

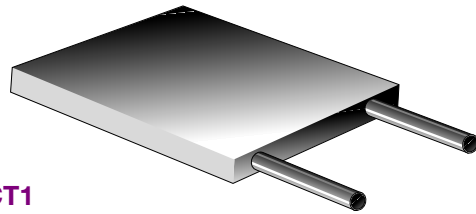

Type CT1

Cooling tube exiting through the thickness toward the ends of the width or length.



Type CT2

Cooling tube exiting through the thickness opposite of each other toward the ends of the width or length.

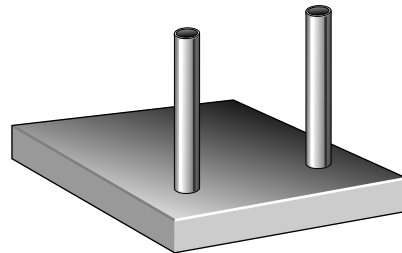

Type CT3

Cooling tube exiting at the ends of the width or length through the top surface.

Platen Heaters—Standard Sizes and Ratings

These sizes and ratings are among the most commonly used. They will provide the shortest lead times. Part numbers are for aluminum heaters unless otherwise specified.



an asterisk next to the Part Number guarantees in-stock availability for same day shipping when



Length in	Width in	Thickness in	Wattage	Volts	Notes	Part Number
3.000	4.000	.750	400	230	(1) $\frac{5}{8}$ " dia. hole	CBH02755
3.500	3.875	1.000	500	220	204" Leads, 182" leads, 180" cable, (1) $\frac{5}{8}$ " dia. hole	CBH04888
3.875	3.500	.750	500	230	(1) $\frac{5}{8}$ " dia. hole	*CBH03468
3.875	3.500	.750	500	230	(1) $\frac{5}{8}$ " dia. hole	CBH03147
4.000	4.000	.750	600	240	60" Leads, 58" armor cable (1) $\frac{9}{16}$ " dia. hole	CBH05665
4.500	4.000	.750	275	240	60" Leads, 58" braid, (2) $\frac{9}{16}$ " dia. hole, (1) 1" dia. hole	CBH05666
4.500	3.500	.750	600	230	(1) $\frac{5}{8}$ " dia. hole	*CBH03065
4.500	4.750	.750	800	220	144" Leads, 120" braid, (1) $\frac{5}{8}$ " dia. hole	*CBH04845
5.000	4.000	.625	600	220	36" Leads, 34" braid, (1) $\frac{9}{16}$ " dia. hole	CBH04395
5.000	6.000	1.000	500	220	204" Leads, 180" braid, (1) $\frac{5}{8}$ " dia. hole	CBH04889
5.375	4.625	.750	275	240	246" Leads, 244" braid, (1) $\frac{9}{16}$ " dia. hole	CBH05511
5.500	3.500	.750	600	220	66" Leads, 64" braid, (1) $\frac{9}{16}$ " dia. hole	*CBH03869
5.500	4.500	.750	900	230	48" Leads, 36" braid, (1) $\frac{9}{16}$ " dia. hole	CBH02698
5.750	4.000	1.000	500	230	(4) $\frac{13}{32}$ " dia. holes, (1) $\frac{1}{8}$ " NPT tap	CBH01722
5.875	3.875	.750	750	230	(1) $\frac{5}{8}$ " dia. hole, 30° at front	*CBH02255
5.875	3.875	.750	750	230	(1) $\frac{5}{8}$ " dia. hole, 30° at front, has ground screw	*CBH04170
5.875	3.875	.750	750	460	(2) $\frac{3}{4}$ " dia. holes, (1) $\frac{5}{8}$ " dia. holes 30° at front	CBH06441
5.875	3.875	.750	500	110	(1) $\frac{5}{8}$ " dia. hole, (2) $\frac{3}{4}$ " dia. cutouts	CBH04531
5.875	5.500	.938	300	230	(3) $\frac{13}{32}$ " dia. holes, (4) $\frac{13}{32}$ " dia. holes	CBH01542
6.000	3.500	.750	800	230	(1) $\frac{5}{8}$ " dia. hole, #10-32 tap (1)	*CBH05693
6.000	3.875	.750	800	230	(1) $\frac{5}{8}$ " dia. hole, (1) $\frac{9}{16}$ " radius cutout	CBH04698
6.000	4.500	.750	800	460	(2) $\frac{5}{8}$ " dia. holes	CBH04104
6.000	4.750	.750	900	220	144" Leads, 120" braid, (1) $\frac{5}{8}$ " dia. holes	CBH04844
6.250	5.469	1.938	1000	230	(2) $\frac{3}{8}$ -16 tap, (2) $\frac{5}{16}$ -18 tap	*CBH01090
7.000	3.000	.750	800	230	264" Leads, 120" braid, (2) $\frac{5}{8}$ " dia. holes	CBH04805
7.500	5.500	1.000	1350	230	208" Leads, 180" braid, (1) $\frac{5}{8}$ " dia. hole	CBH04234
8.000	6.250	1.000	1200	230	(2) $\frac{13}{32}$ " dia. holes, (1) $\frac{1}{8}$ " NPT tap, (3) $\frac{13}{32}$ " slots	CBH01091
8.660	7.874	.433	1250	220	24" Leads, 10" braid, (3) .213" dia. holes, (2) .234" dia. holes	*CBH04086
9.500	6.250	1.000	1700	230	(3) $\frac{13}{32}$ " dia. holes, (3) $\frac{13}{32}$ " slots, (1) $\frac{1}{8}$ " NPT tap	CBH01088
13.250	11.625	1.000	3450	230	(7) $\frac{13}{32}$ " dia. holes, (3) $\frac{13}{32}$ " slots, (1) $\frac{1}{8}$ " NPT tap	CBH01089

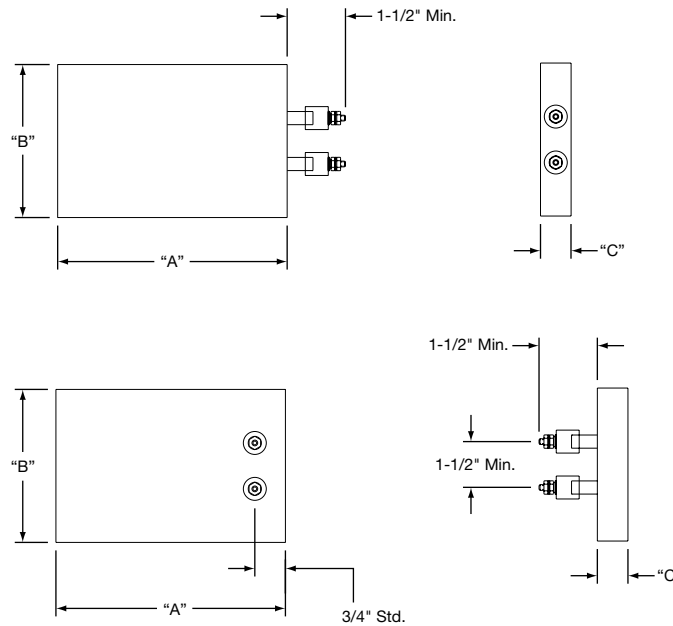

How To Order
To process your order or quotation, please specify the following information.

Variable Dimensions

"A" _____ "B" _____ Thickness "C" _____ Special Features _____

Material Specifications

Aluminum Bronze Brass

Electrical Specifications

Watts each element _____ Volts each element _____ Phase _____

Cooling Tube Sizes

1/4" O.D. SS 3/8" O.D. SS 1/2" O.D. SS Optional Incoloy® (1/2" only) Dual Cooling Tube

Termination Style

"S" Post Terminals "T7" Post Terminals "C4" Ceramic cover
 "R" 90° Blockhead "F" Plain Leads "H" Hermetic Seal
 "E" Right-Angle Lugs "R1" Armor Cable Leads "SF"- "SF9" "P1" Quick-Disconnect
 "TS" Leads and Shrink Sleeve "R2" Blockhead and Through Hole "L"- "L9" Terminal Lug

Terminal Protection Box

"C2" Standard "MR1" Rigid Moisture Resistant "EP" Explosion Resistant
 "MP" Moisture Resistant "MPR" Moisture Resistant
 "P2" High Temperature Quick-Disconnect

Finish

Machined or As Cast. Indicate surfaces to be machined.

Special Cast-In Features

Holes, Cutouts, Slots, Bevels, Mounting Studs, Stand-Offs and Taper Angles.
For special features a detailed drawing is required.



Cast-In Ring Heaters for Plastics Processing Equipment

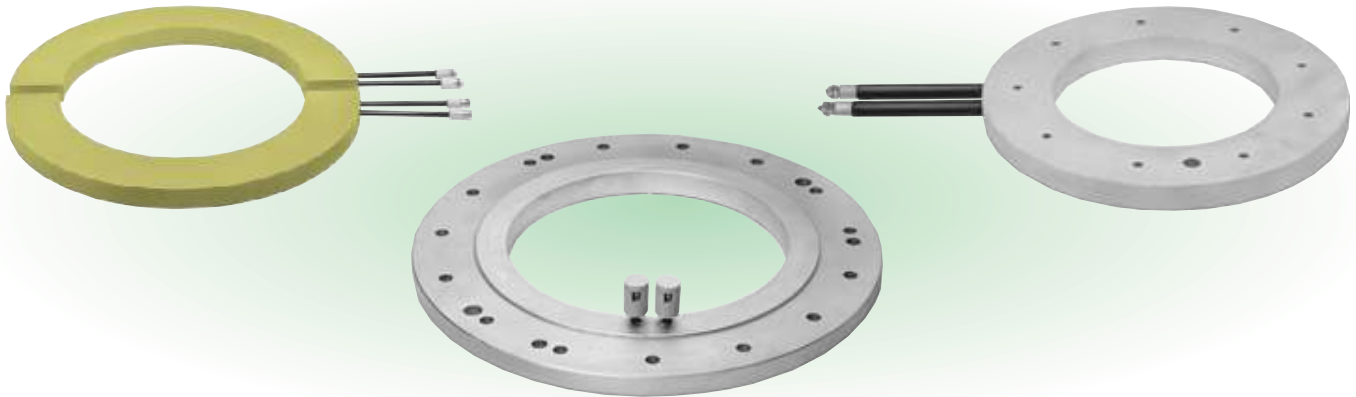

Designed to Heat Limited Access Locations

Tempco Cast-In Ring Heaters provide an excellent means of applying extremely uniform heat to limited access application areas. Cast-In Ring Heaters are frequently used in Blown Film Die, Extrusions Die, Screen Changer and Extruder Barrel Adapter applications where long life and minimal maintenance concerns are prevalent.

The design scope of this product line makes it possible to cast large or small diameter disc shaped rings with nominal thicknesses of 3/4" to 1". These units are an excellent choice for heating the top or bottom of a cylindrical die.

As a standard, Cast-In Ring Heaters are generally manufactured in aluminum because of its superior thermal conductivity. For higher temperature or high watt density requirements, bronze or brass alloys can be used. A variety of standard terminations shown on pages 3-10 and 3-11 are available. The units can be fully machined to include through holes for mounting, thermocouple holes and surface machining.

The Standard Cast-In Ring Heater design features and options include:

- * Computer designed, precisely formed tubular heating element optimizing the heat transfer pattern.
- * Variety of termination options including terminal enclosure housings.
- * Optional 1/4", 3/8", or 1/2" cooling tubes cast into the ring body for liquid cool function.
- * Variety of shapes and sizes.
- * Through holes, tap holes or cutouts to facilitate mounting or obstructions.
- * Precision machining of one or all surfaces of casting—Specify your individual requirements.



Part numbers are for aluminum heaters unless otherwise specified.

CUSTOM Manufactured

For sizes and ratings not listed, **TEMPCO** will design and manufacture a Cast-In Ring Heater to meet your requirements.

Specify the following:

- Inside Diameter
- Outside diameter
- Thickness
- Wattage and Voltage
- Termination type (see pages 3-10 and 3-11)
- Alloy (Aluminum or Bronze)
- Special Features
- Machining Specifications
- Detailed Drawing

I.D. in	O.D. in	Thickness in	Watts	Volts	Special Features	Part Number
5.500	14.000	1.000	2250	230	(8) 9/32" dia. holes	CBH02625
6.750	11.750	1.000	1250	480	(4) 7/16" dia. holes E/H	CBH05499
7.000	11.500	.875	3200	240	(9) 9/32" dia. holes	*CBH01084
7.000	11.500	.875	3200	460	(9) 7/16" dia. holes, (1) 1/2" dia. hole	CBH05415
8.500	13.000	1.000	3000	230	(8) 9/32" dia. holes	CBH01101
10.000	14.500	.875	4000	230	(8) 7/32" dia. hole, (8) 1 1/2" c'bore	*CBH01196
10.000	14.500	.875	1000	230		*CBH01085
12.000	16.250	.875	2125	230	Bronze	*CBH01261
12.000	16.250	.875	2125	230	Bronze	CBH04776
13.000	20.000	1.120	2025	460	(4) 9/16" dia. holes E/H, (2) 1/2"-13" taps	CBH04836
16.250	20.500	1.000	1500	480	(6) 9/16" dia. holes	CBH04943
17.000	20.000	1.500	1250	230	(4) 90° Segments	CBH04990
19.750	34.000	1.130	4000	460	(12) 9/16" dia. holes, (2) 1/2"-13" taps	CBH04837
23.000	29.000	1.000	2000	480	(8) 17/32" dia. holes, (1) 5/8" dia. hole	CBH04220
32.500	40.000	1.125	9000	460	(24) 5/8" dia. holes	CBH02235
43.250	56.250	1.125	4333	290	(16) 9/16" dia. holes	CBH02811

**STOCK ITEMS
ORDER NOW!**

an asterisk next to the Part Number guarantees in-stock availability for same day shipping when

**ORDERED BY 2^{PM}
CST**



Cross Head Die Heaters for Plastics Processing Equipment

Maximize Service Life on Difficult Extrusion Die Applications

Extrusion Cross Head and related extrusion dies present extremely challenging operating parameters to most conventional heating elements. This is primarily due to the presence of excessive contamination, high watt densities and high temperature as well as unusual physical and dimensional requirements.

Many processors continue to use ceramic and mica band heaters on this application, with frequently marginal results. In these instances, Cast-In Aluminum or Bronze heaters are recommended to substantially improve life and performance.

Cast-In Heaters are less susceptible to contamination problems, and can operate at higher temperatures with higher watt densities. In addition, the design is structurally better suited to accommodate holes and cutouts without compromising the heater's electrical and mechanical integrity.

As a standard, Cross Head Die Heaters are typically designed in aluminum as a one-piece band with a single slot that can be slid over the die and clamped with stainless steel clamping straps. For higher temperature or high watt density requirements bronze or brass alloys can be used.

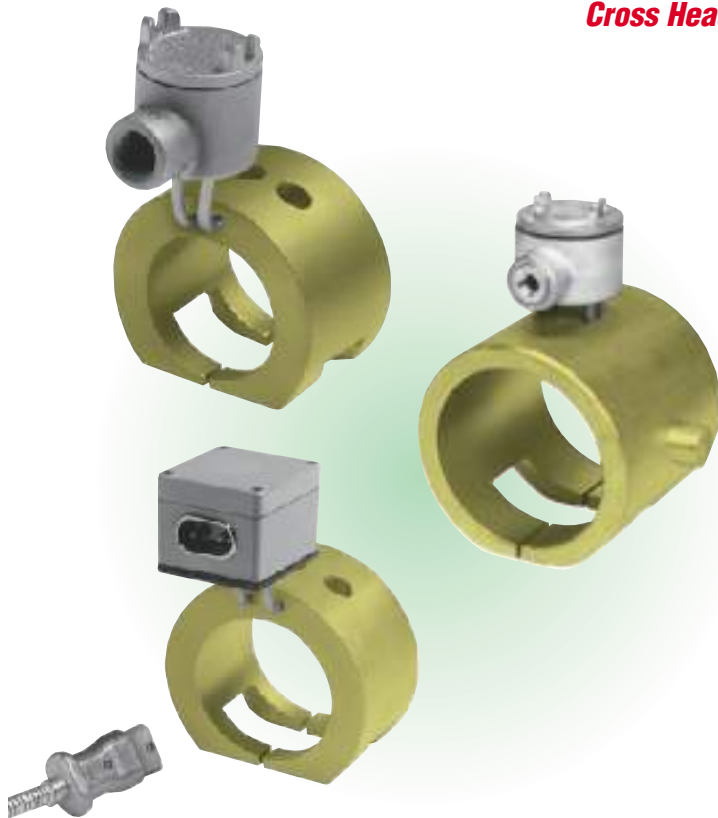

The Standard Cross Head Die Heater design features and options include:

- * Computer designed, precisely formed tubular heating element, optimizing the heat transfer pattern.
- * Variety of termination options, including terminal enclosure housings.
- * Optional 1/4", 3/8", or 1/2" cooling tubes cast into the ring body for liquid cool function.
- * Variety of shapes and sizes.
- * Aluminum and bronze alloys.
- * Through holes, tap holes or cutouts to facilitate mounting or obstructions.
- * Precision machining of one or all surfaces of casting—specify your individual requirements.



Part numbers are for aluminum heaters unless otherwise specified.



an asterisk next to the Part Number guarantees in-stock availability for same day shipping when



CUSTOM Manufactured

For sizes and ratings not listed, **TEMPCO** will design and manufacture a Cross Head Die Heater to meet your requirements.

Specify the following:

- Inside Diameter
- Outside diameter
- Thickness
- Wattage and Voltage
- Termination type (see pages 3-10 and 3-11)
- Alloy (Aluminum or Bronze)
- Special Features
- Machining Specifications
- Detailed Drawing

I.D. in	O.D. in	Length in	Thickness in	Watts	Volts	Special Features	Part Number
2.500	4.000	2.625	.750	750	240	Bronze, (3) 5/8" dia. holes, C7 terminal box	*CBH01913
3.000	4.500	4.000	.750	1200	240	Bronze, (3) 3/4" dia. holes, 2" dia. cutout, R1 cable 70", 72" leads	*CBH02634
3.248	5.248	3.000	1.000	750	230	(3) 3/4" dia. holes, P2 plug, 92" cable, 102" leads	*CBH05491
3.250	5.250	3.000	1.000	1000	240	Bronze, (2) 5/8" and (1) 7/8" dia. hole, (1) 1 3/4" Lg. cutout EP box	*CBH04153
4.000	6.000	3.100	1.000	1200	240	EP Terminal box, (3) 3/4" dia. holes	CBH03979
5.000	6.500	2.250	.750	700	240	Bronze, bolt clamp, (4) 3/4" dia. holes	*CBH03753
5.000	6.500	5.875	.750	2400	240	Bronze, (1) 2 1/2" dia. hole, (2) 7/8" dia. holes	*CBH01382
5.000	7.000	6.500	1.000	3000	460	Brass, CT, EP box, 2.125 x 1.688 cutout	CBH09123
5.687	7.750	8.500	1.031	3000	230	Bronze, CT, EP box, 2.375 x 1.562 cutout	CBH09150
5.998	8.000	4.313	1.000	2400	230	Brass, EP box, (1) 3/4" dia. hole, 2.125 x 1.688 cutout	CBH09180
6.000	8.000	4.313	1.000	2400	460	EP Terminal box, (1) 2 1/2" Lg. cutout, (2) 3/4" dia. holes	CBH04030
7.500	9.500	8.875	1.000	4000	460	Brass, CT, EP box, 2.750 x 1.875 cutout	CBH09124



Special Cast-In Heater Shapes for Plastics Processing Equipment

Plastics Processing Equipment utilizes numerous types of specially designed Cast-In Aluminum and/or Bronze Heaters in addition to the typical and commonly used cylindrical Cast-In Heaters.

The following two pages provide you with a small overview of our foundry capabilities by illustrating some popular Cast-In Heater shapes and how they are used. Special designs can be made to your specifications. Consult Tempco with your requirements.

Platen for Plastic Welding Equipment



"U" Shape for Extrusion Dies



Internal Ring for use inside Cylindrical Die Orifices



Segmented Ring for use on Large Blown Film Dies

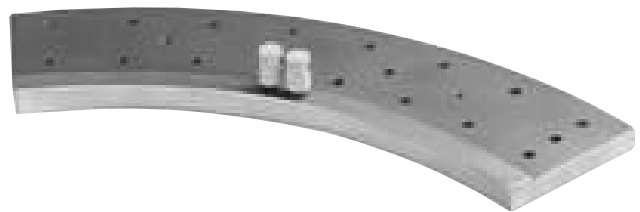

Cylindrical Ring for Cross Head Dies



Full Ring for use with Extruder Adapters





TEMPCO

Your Single Source Solution

"L" Shape for use on Extrusion Dies



Semi-Circular Shape for Screen Changer Equipment



Feed Throat Cooler



Large Holes for Vented Barrels

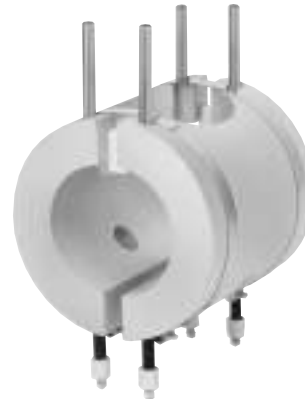

Elbow Heater for Feed Pipe Sections



"L" Shape Heat and Liquid Cool with Cutout





Cast-In Heaters for Commercial, Industrial and Scientific Applications

Setting Standards Through Innovation

Although Tempco is widely recognized as the industry leader in manufacturing Cast-In Heater/Coolers for the plastics industry, our capabilities and the application possibilities for utilizing Cast-In Heater Technology extend far beyond the scope of plastics machinery. For many years Tempco has set industry standards by creating custom designed Cast-In Heaters of every imaginable size, shape and electrical rating that can safely and practically address the diversified requirements of industrial and commercial markets.

Design Flexibility

Cast-In Heaters provide a tremendous advantage in design flexibility, as the nature of our manufacturing process allows a casting to be produced that will fit essentially any industrial or commercial application where heat is required. Tempco's **in-house foundry** capabilities allow us to produce castings in a variety of alloys including aluminum, bronze and brass, yielding a product that can meet the specific thermal, electrical and mechanical requirements of your application. By employing both no-bake sand and permanent mold processes, we can process small and large quantities quickly and economically.

Many specialized applications are not possible to service with conventional heating elements such as cartridge heaters, band and strip heaters or radiant heaters, making Tempco Cast-In Heaters an obvious and practical solution.

UNLIMITED

Cast-In Heaters for Specialized Applications

Tempco specializes in tackling tough, difficult to handle industrial and high volume commercial heating applications such as:

- * **Food Service Equipment**
- * **Medical and Laboratory Equipment**
- * **Silk Screen and Transfer Equipment**
- * **Solvent Reclamation Equipment**
- * **Packaging Machinery**
- * **Laminating Equipment**
- * **Welding Pre-Heat Equipment**
- * **Rubber Molding Presses**
- * **Semiconductor Processing**
- * **Liquid Heat Exchangers**



Cast-In Tubing for Heat-Exchange Applications

For endothermic and exothermic heat-exchange capabilities, ¼", ⅜" or ½" O.D. cooling tubes can be cast-in either with the tubular heating elements or by themselves. This tubing is precision formed to provide rapid, uniform cooling or heating responses and lower the temperature of the process efficiently and safely. This same process can be employed with hot oil heat transfer systems when the control functions of electric heat may be a process concern. For a comprehensive overview of our cooling tube options refer to pages 3-6 and 3-7.

Made to Customer Specifications

Each individual order is reviewed and designed on the latest, state-of-the-art Computer Aided Design programs to virtually eliminate any risk of improper manufacturing specifications.



Our modern machine shop, fully equipped with state-of-the-art equipment, provides precision machining for unparalleled quality.

“Our capabilities are only limited by your imagination!”

Terminations, Machining and Special Options:

The heating elements can be terminated in a wide variety of styles, including hermetic seals for vacuum environments or to prevent contamination or moisture from entering the heater. Selecting the appropriate electrical termination style is critical to optimizing the life and performance of the heater. For a comprehensive overview of our electrical termination options refer to pages 3-10 through 3-13.

Tempco has a fully equipped modern machine shop featuring CNC machine tools that have the capability to finish the castings to your specifications and tolerance, or the product can be shipped “As Cast”. The working surfaces or the entire Cast-In Heater can be Teflon® coated or electroless nickel plated to meet the requirements of laboratory, medical, food service and other industrial applications.

Rugged and Durable Construction for Trouble-Free Service

In addition to the advantages offered by the design flexibility of Cast-In Heaters, customers can expect and rely upon extremely long life and trouble-free service. The basic heating component is a custom designed tubular heating element that is precisely formed to provide an extremely even heat distribution pattern throughout the casting. In many cases the concentration of heat can be optimized to compensate for heat loss on the casting’s perimeter or control excessive heat buildup in the center of the casting. Depending on application requirements, Tempco-Pak mineral insulated cable heaters can be used in place of tubular heating elements to provide higher watt densities or fit physical constraints not possible with conventional heating elements. See Section 5 for more details.

DESIGN POSSIBILITIES OFFERED BY OUR CAST-IN HEATERS...

SPECIAL REFERENCE

To design and manufacture the Cast-In Heater that best suits your commercial, industrial or scientific application, please refer to the following sections for further details:

SECTION	CONTENTS	PAGE
Casting Design Specifications	Alloy, Casting Process, Dimensions, Electrical Specifications, Cooling tube sizes and materials, Special Features	3-4
Cooling Tube Termination Options	Various fitting styles—Brazed, Flared and Hi-Seals	3-8 and 3-9
Electrical Termination Options	Screw Terminals, Flexible Lead Wire, Moisture/Contamination Sealed, Terminal Protection Outlet Boxes	3-10 to 3-13

Consult us with your requirements. No one can do it better than Tempco—

LET US PROVE IT!



Special Cast-In Heater Designs For Commercial, Industrial and Scientific Equipment Applications

Commercial and Industrial Equipment utilizes numerous types of Cast-In Aluminum and/or Bronze Heaters. The nature of the designs range from simplistic to highly complex.

The following two pages will provide you with a small overview of our foundry capabilities by illustrating some popular Cast-In Heater shapes and their applications. Special designs can be made to your specifications. Consult Tempco with your requirements.

Irregularly Shaped Block for Brick Molding Equipment



Interior Finned Shape for Glue Melt Equipment



Bronze Platens for Battery Case Sealing



Platen for Industrial Rubber Molding Presses



Bronze Cylindrical Ring for Packaging Equipment



Platen for Food Service Warming Equipment





TEMPCO

Your Single Source Solution

Irregular Shape for Laminating Radial Edged Surfaces

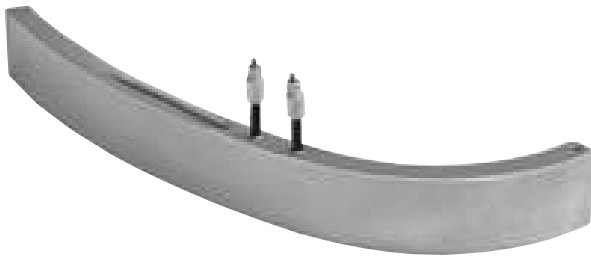

Irregularly Shaped Ring for Industrial Process Equipment

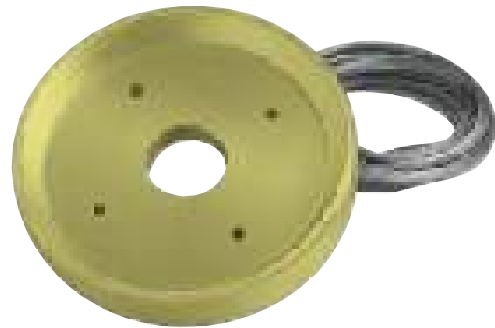

Block with Cast-In Tubing for Heat Exchanger



Ring with Fins used for Dynamic Breaking



Irregularly Shaped Platen for Waste Reclamation Equipment

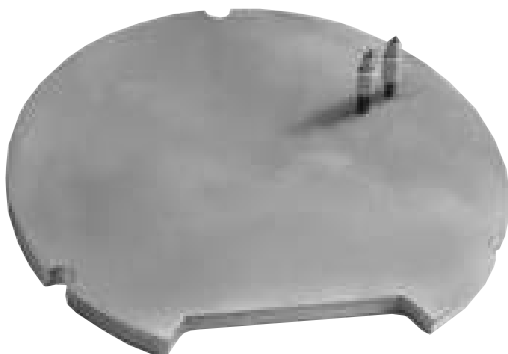

Platen to heat Medical/Lab Samples





Installation Recommendations

Installation Recommendations

Installation

1. Allow sufficient space for thermal expansion. The amount of space required depends upon the Cast-In Heater size and operating temperatures.
2. Surface being heated must be free of any foreign materials and have a smooth finish.
3. Make sure that the casting is properly seated. The clamping devices used should be tightened down as much as possible.
4. After initial heat-up, retighten clamping devices to assure good surface contact.
5. Thermal insulation can be used to reduce heat losses, providing insulation does not come in contact with heaters.
6. Avoid mounting heaters in an atmosphere containing combustible gases and vapors.
7. On Cast-In Heaters equipped with water cool jackets, fittings must be securely tightened due to the high concentration of steam pressure buildup inside the cooling jacket. Flare type or braze seal fittings are recommended over compression type fittings.
8. To prevent overheating and heater failure, adequate temperature controls should be installed. For assistance in selecting temperature controls and thermocouples, see Tempco's (in-stock) complete line of Plug-In type Proportional Temperature Controls for heating and cooling applications in Section 13. Also see listing on standard and hot melt thermocouples in Section 14.

Wiring

1. For connections at the heater terminals, use high temperature nickel conductor lead wire or alloy bus bar. Keep all electrical connections properly protected to eliminate electric shock to machine operators.
2. Heaters of equal wattage and voltage can be series connected for next higher voltage.
3. Heater installations must be properly grounded to eliminate electric shock hazard, and wiring must comply with electrical codes.
4. Always have a qualified electrician perform all wiring and connection of heaters and control components.

Exposed electrical wiring on cast-in heater installations is a violation of Electrical Safety Codes including O.S.H.A.

Tempco Cast-In Heaters will provide long life and dependable, trouble-free service if properly installed, operated, and maintained as per the following recommendations:

Operation

1. Do not operate above rated voltage. Excess voltage will result in heater failure.
2. Do not operate Cast-In Heaters above recommended temperatures. Excess temperatures will result in heater failure.
3. Electrical terminals must be kept free of contaminants, as spillage of plastic, water, oils, and their vapors can cause electric shorts, resulting in heater failure.
4. Cast-In Heaters with water cooling jackets must not be cycled to operate simultaneously. Thermal stresses may result in shorter heater life.
5. The water used on Cast-In Heaters with cooling jackets must be properly treated. Hard water contains corrosive media that will contaminate the tubing on the cooling jacket, producing stress corrosion cracks and resulting in shorter heater life.

Maintenance

1. Never perform any type of service on heaters prior to disconnecting all electrical power.
2. To assure good surface contact, periodically check clamping system.
3. Repeat cycling of temperature controls can indicate poor surface contact or a burned-out heater.
4. Heater terminals must be kept free of plastics, oil, water, and any other foreign matter. As these materials carbonize, they create electrical shorts.
5. Heater terminal electrical connections must be kept tight. Loose connections can overheat and eventually destroy the connection or the heater terminal.
6. Water lines must be periodically checked for leaks. Water on heater terminals can be detrimental to the entire heating system.
7. Thermocouples must be kept free of contaminants and be checked for good response to temperature changes. Our recommendation is to change them periodically as a bad thermocouple can be the cause of destroying an entire heating zone.