

**Mightyband Cable Heaters ..... 5-2**

**Tempco-Pak Cable Heaters..... 5-10**

**Tempco Replacement Heaters  
for OEM Runnerless  
Molding Systems ..... 5-14**

**5**

**SECTION**

# **COIL AND CABLE HEATERS**

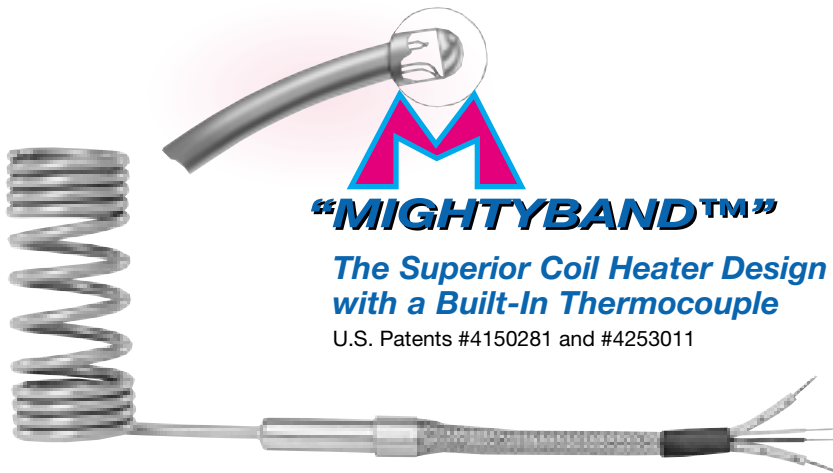

## "MIGHTYBAND™"

*The Superior Coil Heater Design  
with a Built-In Thermocouple*

U.S. Patents #4150281 and #4253011

### Design Features

- \* Temperatures up to 1800°F (982°C)
- \* Precise Temperature Control
- \* Choice of lead orientation
- \* Built-in Type "J" or "K" Thermocouple
- \* Round, Square and Rectangular Cable
- \* Rugged durable construction
- \* Unheated straight section
- \* Fast response time
- \* Choice of lead protection
- \* Longer heater life
- \* Higher Watt Densities
- \* Made to customer specifications

### Construction Characteristics

Tempco's dedication to quality and product improvement has led us into the development of a second generation of Mightyband™ heaters.

Manufactured for trouble free performance in operations involving heating of cylindrical, flat, and irregular shape surfaces where precise temperature control is essential. Especially adapted as an alternate heat source for demanding and high temperature applications where other types of heaters have failed.

The design and manufacturing concept incorporates a built-in thermocouple, with a grounded junction terminating at the end of the cable opposite to the lead end. In some heaters, the thermocouple junction can be terminated anywhere within the coil section. Consult Tempco for the availability of this option on your specific requirement.

The built-in thermocouple and the overall low mass construction provides quick response for positive temperature control, and being part of the heater, it eliminates the need for separate thermocouples, which have proven to be expensive, fragile and not practical.

Standard Type "J" thermocouple with 304 stainless steel heater sheath is recommended for temperatures up to 1500°F (815°C). Optional Type "K" thermocouple with Alloy 600 heater sheath for temperatures up to 1800°F (982°C) is available upon request. In some applications, the built-in thermocouple may not be required. In this case, it can be omitted from the heater cable.

The heating source for the Mightyband™ heater is a resistance wire in straight form or wound into a miniature helical coil. Selecting the best suited resistance wire configuration is predetermined by an engineering formula applied to the specific heater design.

On Mightyband™ heaters where wire wound resistance coils are used, the tail end of the heater cable is usually unheated. Optional unheated or cooler tail sections are available on straight resistance wire heater designs. Consult Tempco with your specific requirements.

The swaging and drawing process involved in manufacturing the heater cable for Mightyband™ heaters compacts the ceramic insulators that house the heating element and thermocouple wire into a solid mass, producing a rugged and durable heater cable, providing excellent thermal conductivity, dielectric strength and quick thermocouple response.

Tempco Mightyband™ heaters have opened new frontiers and revolutionized the plastic injection runnerless molding industry since their introduction by Tempco in 1977. They provided the manufacturers of this type of equipment with a new and more effective heating element concept, thus allowing them to design and manufacture new, improved, and more efficient runnerless molding systems, with the capabilities required to meet the ever increasing demand for processing engineering resins and high production output requirements of today's industrial and consumer markets.

A  
REVOLUTIONARY  
CONCEPT  
IN  
HEATER  
DESIGN

One specific way to improve the Mightyband™ Heater design is to use a square or rectangular mineral insulated cable, which has a flat surface contact, allowing better heat conduction and a faster start-up time.

### Variations and Applications

Mightyband™ heaters lend themselves to a wide range of applications. The flexibility of mineral insulated cable allows the Mightyband™ heater to be coiled, formed, wrapped around pipes or used straight. It can also be cast-in to metal or welded onto machine component parts. Open wound coil heaters can be used as cartridge heaters in irregular size holes.

Tempco offers from stock a large selection of standard Mightyband™ coil heaters for plastic injection runnerless molding bushings and for internally heated injection machine nozzles. The inside diameter of a coiled heater is wound undersized for a screw-on fit. Therefore, hold-down straps are not usually required.





## Typical Configurations



### Star Wound Coil

Star wound formations are usually inserted into pipes or ducts and are used to heat moving air or liquids. The offset coils create a turbulent flow. This allows the flowing material to have better contact with the heater surface, resulting in more efficient heat transfer.

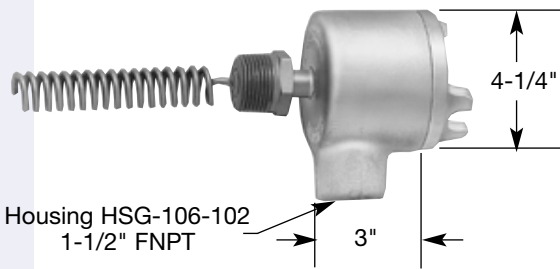

### Explosion or Moisture Resistant Box

Mightyband™ coil heaters can be used for immersion heating and/or in-line heating of liquids, gases or air. The built-in thermocouple provides a self-contained heating unit, eliminating the need for separate thermowells, and is available with standard NPT or special fittings. The outside diameter (O.D.) of the coil must be smaller than the fitting being used for proper fit to the mating part. The wiring can be protected from hazardous environments by attaching explosion or moisture proof boxes. Consult Tempco with your requirements.



### NPT Pipe Fittings

Mightyband™ coil heaters can be used for immersion heating and/or in-line heating of liquids, gases or air. The built-in thermocouple provides a self-contained heating unit, eliminating the need for separate thermowells. Available with standard NPT fittings or special fittings. The outside diameter (O.D.) of the coil must be smaller than the fitting being used for proper fit to the mating part. Consult Tempco with your requirements.

## Lead Orientations

### LO1 Standard

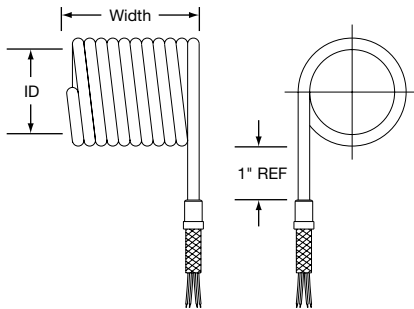

### LO2

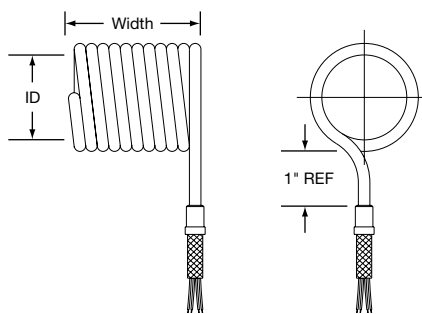

### LO3

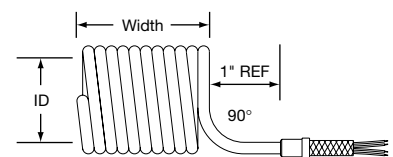

### LO4

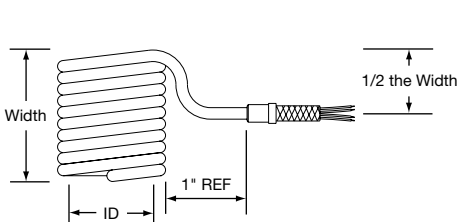

### LO5

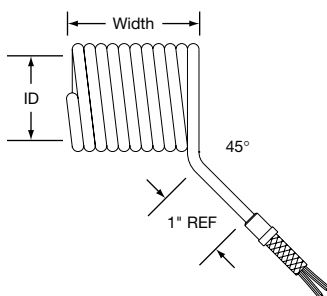

### LO6

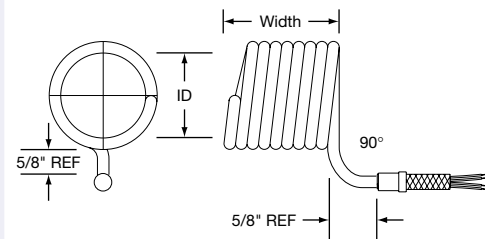

**Other lead orientations available upon request. Consult Tempco with your requirements.**

### Potted Lead Transitions

- The heating element wire to lead wire transition is done within the potting adapter. Potting adapter sizes are  $\frac{5}{16}$ " O.D.  $\times$   $1\frac{1}{2}$ " long for heater cable diameters 0.188" and smaller and  $\frac{1}{2}$ "  $\times$   $1\frac{1}{2}$ " long for diameters above 0.188". Other diameters and lengths are available, depending on design parameters.
- When the  $\frac{1}{2}$ "  $\times$   $1\frac{1}{2}$ " long potting adapter is used for high temperature applications, a special heat sink collar is also used to help keep the transition from overheating.
- All transitions use 1150°F (621°C) braze joint between the heating element wire and the flexible lead wire.
- Normally the lead wire construction is a fiberglass braided insulation rated to 482°F (250°C). For high temperature applications an MGT (mica, fiberglass, Teflon® impregnation) insulation rated to 842°F (450°C) is used. All thermocouple leads use a fiberglass insulation rated to 900°F (482°C). Lead wires are selected to meet the amperage and temperature requirements of each specific heater.

#### Type M\_\_ – Plain Leads

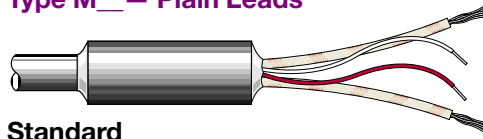

#### Standard

**M1** – High temperature cement potting with TGGT (Teflon® tape, fiberglass, Teflon® treated fiberglass overbraid) insulated lead wire for 482°F (250°C) and silicone sealed is standard.

#### Optional

**M2** – High temperature epoxy potting rated 450°F (232°C) for a better moisture seal.

#### Optional

**M3** – High temperature cement potting with MGT (mica tape, Teflon® treated fiberglass overbraid) insulated lead wire for 842°F (450°C) and silicone sealed.



**Note:** Temperature at potting adapter should not exceed the specified limits.

### Lead Wire Protection

#### Type A\_\_ – Stainless Steel Armor Cable

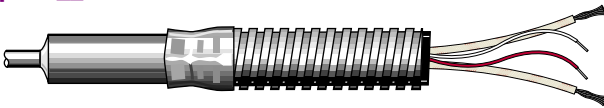

**Type A1** – Rated to 482°F (250°C)

**Type A2** – Rated to 450°F (232°C)

**Type A3** – Rated to 842°F (450°C)

Flexible SS armor cable protects the leads against abrasion and contamination. Special plugs can be attached to heater leads and thermocouple leads.

#### Type C\_\_ – Galvanized Armor Cable



**Type C1** – Rated to 482°F (250°C)

**Type C2** – Rated to 450°F (232°C)

**Type C3** – Rated to 842°F (450°C)

Flexible galvanized armor cable protects the leads against abrasion and contamination. Special plugs can be attached to heater leads and thermocouple leads.

#### Type B\_\_ – Stainless Steel Overbraid

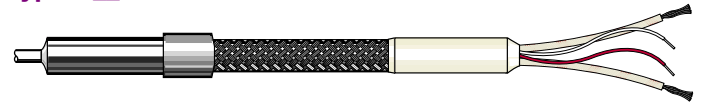

**Type B1** – Rated to 482°F (250°C)

**Type B2** – Rated to 450°F (232°C)

**Type B3** – Rated to 842°F (450°C)

SS overbraid protects the leads against abrasion and allows more aggressive bending, which is not possible with armor cable. Special plugs can be attached to heater and thermocouple leads.

#### Type S\_\_ – Fiberglass Sleeve



**Type S1** – Rated to 482°F (250°C)

**Type S2** – Rated to 450°F (232°C)

**Type S3** – Rated to 842°F (450°C)

Fiberglass sleeve protects the leads against abrasion and allows more flexibility of lead wires. Special plugs can be attached to heater and thermocouple leads.

### Optional Cold Lead Ends

The availability of Tempco-Pak heaters with optional cold lead end depends on the electrical ratings and materials used for each heater design. Consult Tempco for the availability of these options for your particular requirements.

#### Type ND – Neck Down

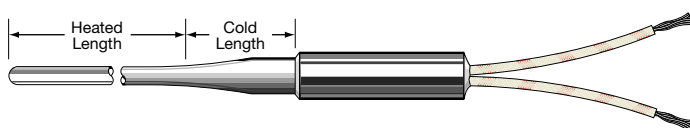

#### Type NW – Built-in Cold Wire

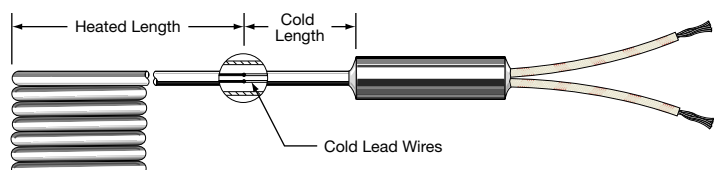



# Square Cable Heaters

## Mightyband™ Coil Heaters with Square MI Cable

TEMPCO offers a square sheathed, mineral insulated, coiled nozzle heater with a built-in-thermocouple. The unique feature of the 1/8" square sheath is a larger sheath contact area as compared to its round sheathed counterpart, allowing for faster start-up cycles. The ANSI Type J standard or optional Type K thermocouple normally has a grounded junction. However, an optional ungrounded junction is available. Heaters can be formed into a compact coiled nozzle heater supplying a full 360° of heat to the distributed wattage coil. The low mass of the heater allows quick response to both heating and cooling.



### Specifications

- Resistance tolerance: . . . . . ±5%
- Wattage tolerance: . . . . . ±5%
- Maximum Wattage: . . . . . 720 watts (for 240 volt heaters)  
300 watts (for 120 volt heaters)
- Maximum operating temperature: . . . . . 1500°F (816°C)
- Maximum Watt density: . . . . . 134 watts/in<sup>2</sup> applied to nozzle
- Physical Dimensions: . . . . . 1/8" square  
(except non-heated tail section, which is 1/8" round)
- Length of non-heated section: . . . . . 1" to 6" (specify when ordering)
- Potting Adapter: . . . . . 5/16" O.D. x 1 1/2" long  
Standard Lead Length as specified in table below (if other than standard specify)

### Standard Features

- \* Standard lead wire construction is a fiberglass braided insulation with stainless steel overbraid suitable for 482°F (250°C). Optional constructions using Teflon® insulation or armor cable are available on request.
- \* The standard wire to M. I. cable transition area (potting adapter) is temperature rated to 450°F (232°C). High temperature 842°F (450°C) is optional.
- \* The ANSI Type J standard or optional Type K thermocouple junction can be grounded at the tip (the end farthest from transition area) or ungrounded anywhere along the length of the heater.
- \* Heaters can be supplied with optional stainless steel clamping straps, which provide additional circumferential clamping forces and protection of the heater coils from accidental damage.
- \* All Mightyband™ coil heaters are available with one (1) of six (6) different lead orientations (LO) as shown on Page 5-4. Other custom lead orientations can be manufactured to suit. Specify lead orientation when ordering.
- \* Can be supplied with optional grounding wire upon special request.



### 1/8" Square Tempco-Pak Cable Heaters Non-heated tail section is 1/8" round

Coil I.D.		Closed Coil Width		Stretched Width		Built-In T/C	Voltage	Wattage	Standard Lead Length		Lead Orientation and Type	Part Number
in	mm	in	mm	in	(mm)				in	(mm)		
.500	12.7	2.00	50.8	2.5	63.5	yes	240	450	40	1016	CL01	MHC00116
.500	12.7	2.50	63.5	4.6	116.8	yes	240	300	48	1219	AL05	MHC00117
.750	19.1	1.25	31.8	—	—	yes	230	125	48	914	ML04	MHC00118
.750	19.1	1.25	31.8	—	—	yes	230	250	48	914	ML04	MHC00119
.750	19.1	1.25	31.8	1.5	38.1	yes	240	300	48	1219	SL05	MHC00120
.750	19.1	0.95	24.1	—	—	yes	240	250	72	1829	ML01	MHC00121
.968	24.6	0.95	40.1	—	—	yes	240	250	72	1829	ML01	MHC00122
.968	24.6	1.58	40.1	—	—	yes	240	300	72	1829	ML01	MHC00123

**Standard Sizes and Ratings**

### How to Order

#### Standard Heaters

Order by Part number for standard heaters listed above for runnerless plastic injection molding, hot sprue bushings and nozzles.

If not otherwise specified, all Mightyband™ heaters are supplied with close wound coiling pattern, Type L01 lead orientation (see page 5-4), 24" of leads and 20" of stainless steel overbraid with Type "J" thermocouple. If longer leads are required—SPECIFY.

#### Custom Engineered/Manufactured Heaters

Understanding that an electric heater can be very application specific, for sizes, ratings and terminations not listed, **TEMPCO** will design and manufacture a Mightyband™ heater to meet your requirements. **Standard lead time is 3 weeks.**

**Please Specify** the following:

- Inside Diameter
- Width (Length)
- Specify width as closed or stretched
- Wattage
- Voltage
- Length of non-heated tail section
- Lead length
- Lead Orientation (see page 5-4)
- Lead Transition (see page 5-5)
- Lead protection (see page 5-5)
- Thermocouple Type—if required



Heater shown with  
Lead Protection B and  
Lead Orientation LO1.



### Round Cable Heaters — Standard Sizes and Ratings

See page 5-5 for Lead Protection and page 5-4 for Lead Orientation descriptions.

Inside Diameter		Outside Diameter		Width		Watts	Volts	Distributed Wattage	Close Wound	Lead Protection	Lead Orientation	Part Number
in	mm	in	mm	in	mm							
1/2	12.7	0.808	20.5	2	50.8	340	240	yes		C	LO2	*MHC00001
1/2	12.7	0.808	20.5	2 1/2	63.5	340	240	yes		C	LO2	*MHC00002
1/2	12.7	0.808	20.5	3	76.2	340	240	yes		C	LO2	*MHC00003
1/2	12.7	0.808	20.5	3 1/2	88.9	340	240	yes		C	LO2	*MHC00004
1/2	12.7	0.808	20.5	3	76.2	380	240	yes		C	LO2	*MHC00005
1/2	12.7	0.808	20.5	3 1/2	88.9	380	240	yes		C	LO2	*MHC00006
1/2	12.7	0.730	18.5	2 1/2	63.5	450	240		yes	C	LO1	MHC00007
1/2	12.7	0.764	19.4	4 1/2	114.3	400	240	yes		C	LO2	MHC00008
1/2	12.7	0.750	19.1	5 1/2	139.7	400	240	yes		C	LO2	*MHC00009
1/2	12.7	0.750	19.1	6 1/2	165.1	400	240	yes		C	LO2	*MHC00010
1/2	12.7	0.750	19.1	4 5/8	117.5	300	240		yes	C	LO1	*MHC00011
1/2	12.7	0.764	19.4	2	50.8	340	120		yes	C	LO2	*MHC00012
1/2	12.7	0.764	19.4	2 1/2	63.5	340	120	yes		C	LO2	*MHC00013
1/2	12.7	0.764	19.4	3	76.2	380	120	yes		C	LO2	*MHC00014
1/2	12.7	0.764	19.4	3 1/2	88.9	380	120	yes		C	LO2	*MHC00015
1/2	12.7	0.744	18.9	4 1/2	114.3	400	120	yes		C	LO2	*MHC00016
1/2	12.7	0.744	18.9	5 1/2	139.7	400	120	yes		C	LO2	*MHC00017
1/2	12.7	0.744	18.9	6 1/2	165.1	400	120	yes		C	LO2	*MHC00018
1/2	12.7	0.750	19.1	4 5/8	117.5	300	120		yes	C	LO1	*MHC00019
5/8	15.9	0.931	23.6	2	50.8	300	240	yes		C	LO2	MHC00020
5/8	15.9	0.931	23.6	2 1/2	63.5	325	240	yes		C	LO2	MHC00021
5/8	15.9	0.891	22.6	2	50.8	330	120		yes	B	LO2	MHC00022
5/8	15.9	0.875	22.2	2	50.8	330	240		yes	B	LO2	*MHC00023
5/8	15.9	0.875	22.2	2 1/2	63.5	330	240	yes		B	LO2	*MHC00024
5/8	15.9	0.875	22.2	3	76.2	330	240	yes		B	LO2	*MHC00025
5/8	15.9	0.875	22.2	3	76.2	380	240	yes		C	LO2	MHC00026
5/8	15.9	0.875	22.2	3	76.2	360	240		yes	B	LO2	MHC00027
5/8	15.9	0.875	22.2	4	101.6	360	240	yes		B	LO2	MHC00028
5/8	15.9	0.875	22.2	4	101.6	500	240		yes	B	LO2	MHC00029
5/8	15.9	0.875	22.2	5	127.0	500	240	yes		C	LO2	MHC00030
5/8	15.9	0.875	22.2	6	152.4	550	240	yes		C	LO2	MHC00031
3/4	19.1	1.056	26.8	1 1/4	31.8	250	230		yes	M	LO1	MHC00032
3/4	19.1	1.056	26.8	1 1/4	31.8	125	230		yes	M	LO1	MHC00033
3/4	19.1	1.000	25.4	1 1/4	31.8	400	120		yes	B	LO1	MHC00034
3/4	19.1	1.000	25.4	2	50.8	365	120		yes	B	LO1	MHC00035
3/4	19.1	1.016	25.8	2	50.8	135	240		yes	B	LO1	MHC00036
3/4	19.1	1.000	25.4	3	76.2	750	240		yes	B	LO1	MHC00037
3/4	19.1	0.972	24.7	5	127.0	600	240		yes	B	LO1	MHC00038
3/4	19.1	0.992	25.2	8 1/2	215.9	1300	240		yes	B	LO1	MHC00039
7/8	22.2	1.181	30.0	1	25.4	400	120		yes	B	LO1	MHC00040
7/8	22.2	1.181	30.0	1 1/4	31.8	250	240		yes	P	LO2	MHC00041
7/8	22.2	1.181	30.0	2	50.8	400	240	yes		C	LO2	MHC00042
7/8	22.2	1.181	30.0	2 5/8	66.7	480	240	yes		C	LO2	*MHC00043
7/8	22.2	1.181	30.0	3 1/8	79.4	480	240	yes		C	LO2	*MHC00044

❖ Denotes the Thermocouple Junction is located between third and fourth coil from the tip end, isolated from the sheath.

**STOCK ITEMS**  
**ORDER NOW!**

an asterisk next to the Part Number  
guarantees in-stock availability  
for same day shipping when

**ORDERED BY 2<sup>PM</sup>**  
CST

**CONTINUED**



Heater shown with Lead Protection B and Lead Orientation LO1.

### Round Cable Heaters — Standard Sizes and Ratings (continued)

See page 5-5 for Lead Protection and page 5-4 for Lead Orientation descriptions.

Inside Diameter		Outside Diameter		Width		Watts	Volts	Distributed Wattage	Close Wound	Lead Protection	Lead Orientation	Part Number
in	mm	in	mm	in	mm							
7/8	22.2	1.115	28.3	2	50.8	670	120		yes	B	LO2	MHC00045
7/8	22.2	1.125	28.6	2	50.8	670	240		yes	B	LO2	*MHC00046
7/8	22.2	1.125	28.6	2 1/2	63.5	670	240	yes		B	LO2	*MHC00047
7/8	22.2	1.125	28.6	3 1/8	79.4	670	240	yes		B	LO2	*MHC00048
❖ 7/8	22.2	1.181	30.0	2 1/2	63.5	450	240	yes		C	LO2	MHC00049
7/8	22.2	1.181	30.0	3 5/8	92.1	550	240	yes		C	LO2	*MHC00050
7/8	22.2	1.181	30.0	4 5/16	109.5	550	240	yes		C	LO2	*MHC00051
7/8	22.2	1.181	30.0	5 5/16	134.9	650	240	yes		C	LO2	MHC00052
7/8	22.2	1.181	30.0	6 5/16	160.3	650	240	yes		C	LO2	MHC00053
7/8	22.2	1.181	30.0	7 5/16	185.7	650	240	yes		C	LO2	MHC00054
❖ 7/8	22.2	1.125	28.6	3	76.2	680	240	yes		C	LO2	MHC00055
❖ 7/8	22.2	1.125	28.6	3 1/2	88.9	700	240	yes		C	LO2	MHC00056
7/8	22.2	1.095	27.8	3 5/8	92.1	770	240	yes		B	LO2	*MHC00057
7/8	22.2	1.095	27.8	4 5/16	109.5	770	240	yes		B	LO2	*MHC00058
7/8	22.2	1.095	27.8	5 5/16	134.9	770	240	yes		B	LO2	*MHC00059
7/8	22.2	1.125	28.6	4	101.6	775	240	yes		C	LO2	MHC00060
7/8	22.2	1.125	28.6	6 5/16	160.3	730	240	yes		B	LO2	*MHC00061
7/8	22.2	1.125	28.6	7 5/16	185.7	730	240	yes		B	LO2	*MHC00062
❖ 7/8	22.2	1.125	28.6	5	127.0	900	240	yes		C	LO2	MHC00063
7/8	22.2	1.105	28.1	8 5/16	211.1	730	240	yes		C	LO2	*MHC00064
7/8	22.2	1.105	28.1	9 5/16	236.5	730	240	yes		C	LO2	*MHC00065
7/8	22.2	1.105	28.1	10 9/16	261.9	730	240	yes		C	LO2	*MHC00066
❖ 7/8	22.2	1.125	28.6	6	152.4	1000	240	yes		C	LO2	MHC00067
7/8	22.2	1.105	28.1	11 5/16	287.3	850	240	yes		C	LO2	*MHC00068
7/8	22.2	1.105	28.1	12 9/16	312.7	850	240	yes		C	LO2	*MHC00069
7/8	22.2	1.105	28.1	13 3/16	338.1	850	240	yes		C	LO2	*MHC00070
7/8	22.2	1.105	28.1	14 5/16	363.5	850	240	yes		C	LO2	*MHC00071
7/8	22.2	1.105	28.6	7	177.8	1100	240	yes		C	LO2	MHC00072
1	25.4	1.250	31.8	1 1/2	38.1	375	120		yes	B	LO1	MHC00073
1	25.4	1.306	33.2	1 1/2	38.1	375	240		yes	B	LO1	MHC00074
1	25.4	1.240	31.5	2	50.8	400	120		yes	B	LO1	MHC00075
1	25.4	1.266	32.2	2 1/2	63.5	450	120		yes	B	LO1	MHC00076
1	25.4	1.250	31.8	8	203.2	1250	240		yes	B	LO1	MHC00077
1 1/4	31.8	1.556	39.5	1	25.4	340	240		yes	B	LO1	MHC00078
1 1/4	31.8	1.556	39.5	1 1/4	31.8	375	120		yes	B	LO1	MHC00079
1 1/4	31.8	1.480	37.6	1 1/2	38.1	400	120		yes	B	LO1	MHC00080
1 1/4	31.8	1.492	37.9	2	50.8	475	120		yes	B	LO1	MHC00081
1 1/4	31.8	1.480	37.6	2 1/2	63.5	750	240		yes	C	LO2	*MHC00082
1 1/4	31.8	1.514	38.5	4 1/2	114.3	1250	240		yes	C	LO2	*MHC00083
1 1/4	31.8	1.534	39.0	6 1/2	165.1	1800	240		yes	C	LO2	*MHC00084
1 1/4	31.8	1.548	39.3	7	177.8	2000	240		yes	B	LO1	MHC00085
1 1/4	31.8	1.594	40.5	8 1/2	215.9	2335	240		yes	C	LO2	MHC00086
1 1/4	31.8	1.626	41.3	10 1/2	266.7	2500	240		yes	C	LO2	*MHC00087

❖ Denotes the Thermocouple Junction is located between third and fourth coil from the tip end, isolated from the sheath.

**STOCK ITEMS**  
**ORDER NOW!**

an asterisk next to the Part Number guarantees in-stock availability for same day shipping when

**ORDERED BY 2<sup>PM</sup> CST**

**CONTINUED**





### Round Cable Heaters — Standard Sizes and Ratings (continued)

See page 5-5 for Lead Protection and page 5-4 for Lead Orientation descriptions.

Inside Diameter		Outside Diameter		Width		Watts	Volts	Distributed Wattage	Close Wound	Lead Protection	Lead Orientation	Part Number
in	mm	in	mm	in	mm							
1½	38.1	1.806	45.9	1	25.4	400	120		yes	B	LO1	MHC00088
1½	38.1	1.730	43.9	1¼	31.8	425	120		yes	B	LO1	MHC00089
1½	38.1	1.742	44.2	1½	38.1	525	120		yes	B	LO1	MHC00090
1½	38.1	1.742	44.2	2	50.8	475	120		yes	B	LO1	MHC00091
1½	38.1	1.752	44.5	2	50.8	475	240		yes	B	LO1	MHC00092
1½	38.1	1.754	44.6	2	50.8	550	240		yes	B	LO1	MHC00093
1½	38.1	1.742	44.2	2½	63.5	600	120		yes	B	LO1	MHC00094
1½	38.1	1.766	44.9	2½	63.5	600	240		yes	B	LO1	MHC00095
1½	38.1	1.742	44.2	3	76.2	475	120		yes	B	LO1	MHC00096
1½	38.1	1.732	44.0	3	76.2	875	240		yes	B	LO2	*MHC00097
1½	38.1	1.750	44.5	4⅞	104.8	1000	240	yes		C	LO2	MHC00098
1½	38.1	1.732	44.0	4	101.6	1000	240		yes	B	LO2	*MHC00099
1½	38.1	1.750	44.5	5⅞	130.2	1000	240	yes		C	LO2	MHC00100
1½	38.1	1.742	44.2	5	127.0	1200	240		yes	B	LO1	MHC00101
1½	38.1	1.766	44.9	6⅞	155.6	1200	240	yes		B	LO2	MHC00102
1½	38.1	1.750	44.5	7⅞	181.0	1100	240	yes		C	LO2	MHC00103
1½	38.1	1.806	45.9	6	152.4	675	120		yes	B	LO1	MHC00104
1½	38.1	1.750	44.5	6	152.4	1200	240		yes	B	LO2	*MHC00105
1½	38.1	1.750	44.5	8⅞	206.4	1250	240	yes		B	LO2	MHC00106
1½	38.1	1.750	44.5	9⅞	231.8	1400	240	yes		B	LO2	MHC00107
1½	38.1	1.750	44.5	10⅞	257.2	1800	240	yes		B	LO2	MHC00108
1¾	44.5	1.982	50.3	1	25.4	475	120		yes	B	LO1	MHC00109
1¾	44.5	2.000	50.8	1½	38.1	625	240		yes	B	LO1	MHC00110
1¾	44.5	2.000	50.8	2	50.8	675	240		yes	B	LO1	MHC00111
1¾	44.5	1.982	50.3	2½	63.5	725	240		yes	B	LO1	MHC00112
1¾	44.5	2.056	52.2	7	177.8	2000	240		yes	B	LO2	MHC00113
2	50.8	2.250	57.2	1⅞	34.9	450	240		yes	B	LO1	MHC00114
2	50.8	2.326	59.1	6½	165.1	2400	240		yes	B	LO1	MHC00115

### How to Order

#### Standard Heaters

Order by Part Number for standard heaters listed in Tables on pages 5-7 through 5-9.

#### Custom Engineered/Manufactured Heaters

Understanding that an electric heater can be very application specific, for sizes, ratings and terminations not listed, **TEMPCO** will design and manufacture a Mightyband™ heater to meet your requirements. **Standard lead time is 3 weeks.**

**Please Specify** the following:

- Watts
- Volts
- Coil I.D.
- Coil width (length)
- Distributed wattage if required
- Sheath material— 304 stainless steel or Alloy 600.
- Sheath Diameter if necessary.
- Length of internal nickel cold, or if a neck down design, length of cold section. See page 5-5.
- Thermocouple if required— Type J or K
- Thermocouple Junction— Grounded or Ungrounded. If ungrounded, specify location.
- Transition type: M1, M2, M3, B1, B2, B3, C1, C2 or C3. See page 5-5.
- Lead orientation: LO1, LO2, LO3, LO4, LO5, or LO6. See page 5-4.
- Lead length if other than 24"
- Supply a sketch or drawing

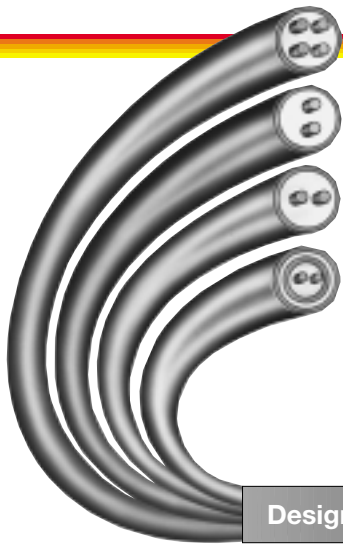

The densely compacted MgO insulation used in Tempco-Pak heaters produces excellent high temperature insulation resistance and dielectric strength. Heaters can be manufactured with the optional cold nickel leads internally spliced to the heating element wires within the same continuous sheath.

Generally speaking, there is very little temperature difference between the sheath and heater wires. Tempco recommends not exceeding 150 watts per square inch of sheath surface area with the sheath operating temperature at 1000°F (537°C) or less. As temperature increases above 1000°F, the maximum watt density should be decreased.

The maximum recommended operating temperature is 1800°F (982°C) with Alloy 600 sheath and ANSI Type K thermocouple if required. Heater life in any specific situation or application is impossible to predict. However, heater life generally decreases as temperature and/or the number of thermal cycles increases.

Tempco-Pak heaters are flexible and can be readily formed or bent by hand or production machinery, with the minimum bend radius equal to twice the sheath diameter. The heater sheath can be welded, brazed or soldered without changing its electrical characteristics.

### Design and Construction Specifications

### Tempco-Pak Heaters with Straight Wire

Tempco-Pak heaters are made from M.I. cable having 2 straight heating element wires insulated from the sheath by high purity MgO.

Available in nominal sheath diameters from 0.040" to 0.375" (1 mm to 9.5 mm) in 304 stainless steel and Alloy 600 for Tempco-Pak heaters with straight wire. Optional cold nickel lead spliced to heating element wire is available in 0.125" diameter or larger depending on conductor material.

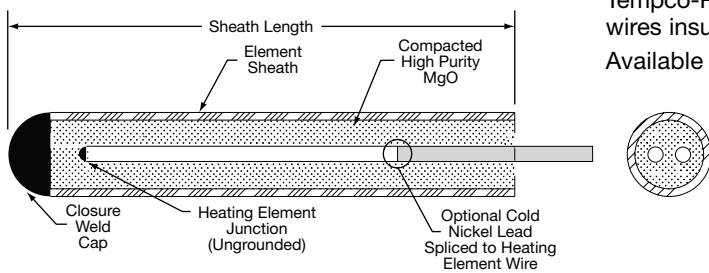

Nominal Sheath O.D.		Maximum Heater Length		Nominal Sheath O.D.		Maximum Heater Length	
in	mm	ft	meters	in	mm	ft	meters
.040	1.00	25	7.6	.188	4.77	100	30.5
.063	1.60	70	21.0	.250	6.35	59	18.0
.125	3.18	120	36.5	.312	7.93	38	11.5
.163	4.14	130	39.6	.375	9.53	26	8.0

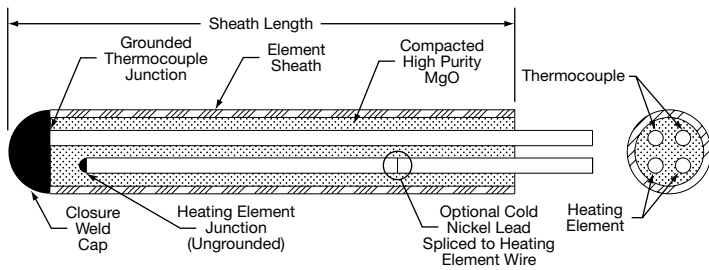

### Tempco-Pak Heaters with Straight Wire and Built-In Thermocouple

Tempco-Pak heaters with 0.125" or larger diameter are also made from M.I. cable having 2 straight heating element wires and 2 straight thermocouple wires insulated from the sheath by high purity MgO. Optional cold nickel lead spliced to heating element wire is available in 0.125" diameter or larger depending on conductor material.

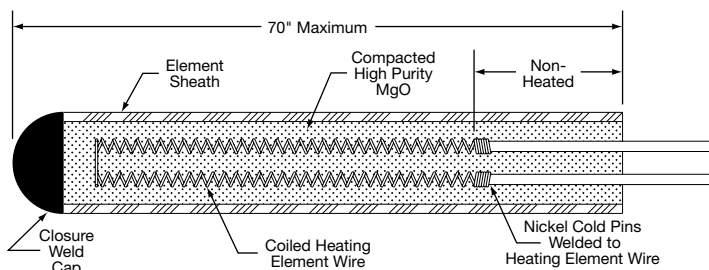

### Tempco-Pak Heaters with Helically Coiled Wire

Hi-Density Tempco-Pak heaters are manufactured from sheathed M.I. cable having 2 coiled heating element wires or 2 coiled heating element wires and 2 straight thermocouple wires. The non-heated portion has the largest possible diameter solid nickel cold pins attached to the heating element wires, providing maximum current carrying capacity within the same continuous sheath.

Available in nominal sheath diameters from 0.120" to 0.153" (3.05 mm to 3.9 mm) including 0.125" O.D., 0.132" O.D. and 0.143" O.D. Tempco also manufactures .110" x .160" rectangular cable as well as .125" square cable.

Maximum sheath length including non-heated section is 70 inches (1778 mm).

Optional Built-in Thermocouple is ANSI Type J or Type K grounded at tip (end farthest from cold end) or ungrounded anywhere along heater length for .125" diameter and larger.



### Performance Ratings

Watt Density: . . . . . 150 watts per square inch of sheath surface area maximum with factory approval  
 Maximum temperature: . . . . . 1500°F (815°C) for 304 stainless steel sheath  
 1800°F (982°C) for Alloy 600 sheath

### Electrical

Resistance: . . . . . ±10% unless otherwise specified  
 Voltage: . . . . . 120V and 240V standard  
 Thermocouples: . . . . . ANSI Type J to 1500°F (815°C)  
 Type K to 1800°F (982°C)

All thermocouples and their junctions are internal to the heater sheath. A grounded junction at the heater tip is standard. An ungrounded junction anywhere along the heater's length is optional. Available in sheath diameters .125" and larger.

### Dimensional

Heater cable diameters: . . . . . .040", .062", .115", .120",  
 .125", .132", .153", .163",  
 .174", .188", .220", .250".  
*Others available upon request.*

Cable diameter tolerance: . . . . . ±.005

Heater length tolerance: . . . . . 0 to 6" (+1/8", -0)  
 6 to 18" (+1/4", -0)  
 18 to 24" (+3/8", -0)  
 24 to 120" (+3/4", -0)  
 120 to 300" (±1")

### Transition and Termination

**Transition (potting) adapters:** 5/16" O.D. × 1 1/2" long for heater cable .188" diameter and smaller. 1/2" O.D. × 1 1/2" long for heater cable diameters above .188"

**Transition Temperature Rating:** Standard transition is rated to 450°F (232°C)

Optional High Temperature Transition is rated to 842°F (450°C)

Standard heater lead wire insulation is TGGT (Teflon®, double fiberglass, Teflon® impregnation), which is rated to 482°F (250°C).

Optional high temperature insulation is MGT (mica, fiberglass, Teflon® impregnation) which is rated to 842°F (450°C).

**Thermocouple:** Standard leads use a fiberglass insulation rated to 900°F (482°C). Teflon® insulation is available upon request.

**Optional lead protection:** Stainless steel overbraid or galvanized armor cable.

### Tempco-Pak Heaters (unformed) — Standard Sizes and Ratings

Part Numbers are for heaters with standard lead length of 24". Longer lead length as well as stainless steel wire braid protection or armored cable protection is available upon request.

Cable Diameter	Sheath Length		Watts	Watt Density		Volts	Part Number
	in	mm		W/in <sup>2</sup>	W/cm <sup>2</sup>		
+.062" (1.57 mm)	34	863.6	400	60	9.30	120	HHS00001
	42	1066.8	400	49	7.59	120	HHS00002
	60	1524.0	200	19	2.94	120	HHS00003
	88	2235.2	450	26	4.03	120	HHS00004
.115" (2.92 mm)	39	990.6	450	32	4.96	240	MHS00001
	49	1244.6	425	24	3.72	120	MHS00002
	73	1854.2	450	17	2.63	120	MHS00003
	87	2209.8	750	24	3.72	240	MHS00004
.125" (3.18 mm)	30	762.0	300	30	4.65	120	MHS00005
	35	889.0	330	24	3.72	240	MHS00006
	41	1041.4	365	23	3.56	120	MHS00007
	52	1320.8	400	20	3.10	240	MHS00008
	62	1574.8	780	32	4.96	240	MHS00009
	68	1727.2	300	11	1.70	120	MHS00010
	68	1727.2	300	11	1.70	240	MHS00011
	84	2133.6	780	24	3.72	120	MHS00012
90	2286.0	660	19	2.94	120	MHS00013	
.153" (3.89 mm)	17	431.8	200	24	3.72	240	MHS00014
	17	431.8	375	46	7.13	240	MHS00015
	18	457.2	250	29	4.49	240	MHS00016
	20	508.0	125	13	2.01	230	MHS00017
	20	508.0	250	26	4.03	230	MHS00018
	22	558.8	250	24	3.72	240	MHS00019
	25	635.0	380	32	4.96	240	MHS00020
	34	863.6	480	29	4.49	240	MHS00021
	40	1016.0	550	29	4.49	240	MHS00022
	51	1295.4	650	27	4.18	240	MHS00023

✦ Not available with Built-In Thermocouple





## Tempco-Pak Heaters (unformed) — Standard Sizes and Ratings (continued)

Part Numbers are for heaters with standard lead length of 24". Longer lead length as well as stainless steel wire braid protection or armored cable protection is available upon request.

Cable Diameter	Sheath Length		Watts	Watt Density		Volts	Part Number
	in	mm		W/in <sup>2</sup>	W/cm <sup>2</sup>		
<b>.174"</b> (4.42 mm)	88	2235.2	1800	37	5.73	220	MHS00024
	93	2362.2	1700	33	5.11	220	MHS00025
	109	2768.6	1500	25	3.87	220	MHS00026
	166	4216.4	3350	37	5.73	220	MHS00027
	220	5588.0	2850	24	3.72	220	MHS00028
<b>.188"</b> (4.78 mm)	77	1955.8	1700	34	5.27	220	MHS00029
	90	2286.0	2000	37	5.73	220	MHS00030
	105	2667.0	1800	29	4.49	220	MHS00031
	180	4572.0	3900	37	5.73	220	MHS00032
	191	4851.4	1000	9	1.39	220	MHS00033
<b>.203"</b> (5.16 mm)	198	5029.2	3600	31	4.80	220	MHS00034
	146	3708.4	2850	31	4.80	380	MHS00035
	182	4622.8	3900	34	5.27	480	MHS00036
	200	5080.0	4300	34	5.27	220	MHS00037
<b>.220"</b> (5.59 mm)	223	5664.2	4000	28	4.34	220	MHS00038
	107	2717.8	2500	32	4.96	220	MHS00039
	123	3124.2	2100	31	4.80	220	MHS00040
	205	5207.0	4800	34	5.27	220	MHS00041
<b>.232"</b> (5.89 mm)	217	5511.8	3800	25	3.87	220	MHS00042
	109	2768.6	2700	34	5.27	220	MHS00043
	119	3022.6	2550	29	4.49	220	MHS00044
	204	5181.6	4500	30	4.65	480	MHS00045
<b>.250"</b> (6.35 mm)	211	5359.4	5000	32	4.96	220	MHS00046
	222	5638.8	4800	30	4.65	220	MHS00047
	89	2260.6	2600	37	5.73	220	MHS00048
	100	2540.0	2200	38	5.89	220	MHS00049
	103	2616.2	2750	34	5.27	220	MHS00050
	105	2667.0	2100	25	3.87	220	MHS00051
	115	2921.0	2450	27	4.18	220	MHS00052
	118	2997.2	2600	28	4.34	220	MHS00053
	123	3124.2	2700	28	4.34	220	MHS00054
130	3302.0	2600	25	3.87	220	MHS00055	
138	3505.2	2300	21	3.25	220	MHS00056	
205	5207.0	4200	30	4.65	220	MHS00057	
215	5461.0	4000	28	4.34	220	MHS00058	
240	6096.0	5500	26	4.03	220	MHS00059	
281	7137.4	4700	19	2.94	220	MHS00060	

### How to Order

#### Standard Heaters

Order by Part Number for standard heaters listed in Tables on pages 5-11 and 5-12.

Part Numbers are for heaters with standard lead length of 24". Longer lead length as well as stainless steel wire braid protection or armored cable protection are available upon request.

Heaters under 72" (1829 mm) will be shipped straight, longer heaters will be shipped in coils a minimum 24" (610 mm) in diameter.

#### Custom Engineered/Manufactured Heaters

For sizes, ratings and terminations not listed, **TEMPCO** will design and manufacture a Tempco-Pak heater to meet your requirements. **Standard lead time is 3-4 weeks.**

**Please Specify** the following:

- Wattage and Voltage
- Sheath Diameter
- Heater length
- Sheath material— 304 stainless steel or Alloy 600
- Length of internal nickel cold, or if a neck down design, length of cold section. See page 5-5.
- Thermocouple if required— Type J or K
- Thermocouple Junction— Grounded or Ungrounded. If ungrounded, specify location (.115" and larger)
- Transition type: M1, M2, M3, B1, B2, C1 or C2. See page 5-5.
- Lead length if other than 24"
- Supply a sketch or drawing



# FORMED & HEATERS STRAIGHT

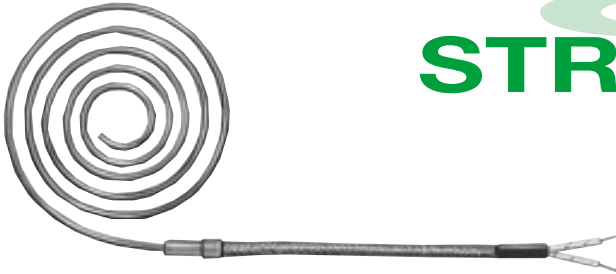

**Spiral wound Tempco-Pak heater cables** are low profile and capable of generating high operating temperatures in restricted areas. The built-in thermocouple eliminates the need for a separate thermocouple. Works especially well as an alternative heat source for flat surface heating applications where other types of heaters cannot be used due to space restrictions. Consult Tempco with your requirements.



**Sinuated (formed) Tempco-Pak heater cables** are low profile and capable of generating high operating temperatures in restricted areas. The built-in thermocouple eliminates the need for a separate thermocouple. Works especially well as an alternative heat source for flat surface heating applications where other types of heaters cannot be used due to space restrictions. The sinuated cable can also be formed to conform to a cylindrical inside or outside surface. Consult Tempco with your requirements.



**Compression fittings** are available on straight cable heaters of various diameters ( $\frac{1}{8}$ " ,  $\frac{3}{16}$ " ,  $\frac{1}{4}$ " ,  $\frac{5}{16}$ " and  $\frac{3}{8}$ " ). This fitting enables adjustment of the insertion length during installation. Compression fittings are available in Brass or Stainless Steel with standard male NPT threads. When ordering, specify heater sheath material, NPT size and material for compression fittings, insertion length, thermocouple type and type of junction (grounded or ungrounded), thermocouple and heater lead lengths, watts and volts, optional—thermocouple location and cooler or unheated cable lengths. Consult Tempco with your requirements.



**Stainless steel mounting flange is 1" diameter  $\times$  .060" thick** with two  $\frac{1}{4}$ " holes on a  $\frac{3}{4}$ " bolt circle. When ordering, specify location of mounting flange, cable diameter, length, sheath material, thermocouple type and type of junction (grounded or ungrounded), thermocouple and heater lead lengths, watts and volts, optional—thermocouple location and cooler or unheated cable lengths. Consult Tempco for the availability on your specific requirements.

**Note:** Mounting flange to be located over a cold or cooler section.



**Straight cable heaters** can be made in a large selection of lengths and diameters. When ordering, specify heater sheath material, thermocouple type and type of junction (grounded or ungrounded), thermocouple and heater lead lengths, watts and volts, optional—thermocouple location and cooler or unheated cable lengths. Consult Tempco for the availability on your specific requirements.



**Miniature Coil heaters** are made for special applications. Cable diameter is less than .100". They work especially well as an alternative heat source for demanding and high temperature applications where other types of heaters have failed. Available with cooler or unheated cable section toward lead end. Consult Tempco with your requirements.

**“Our capabilities are limited only by your imagination!”**



## Stock Tempco Replacement Heaters and Thermocouples for OEM Hot Runner Systems

**SAME DAY SHIPMENT**  
*on stock items* **2 PM**  
**ORDERED BY** **2 CST**

### For Flow Through Type Hot Sprue Bushings

- $\frac{1}{8}$ " square M.I. cable
- Type J ungrounded thermocouple junction in the mid-section of the coil heater
- 48" of leads and 44" of SS armored cable

Coil I.D.	Coil Width	Watts	Volts	OEM Part Number	TEMPCO Part Number
.500	4.625	300	120	SSTC-31	MHC00124
.500	4.625	300	240	SSTC-32	MHC00125
.500	2.500	450	240	SSTC-42	MHC00126

### For Flow Through Type Hot Sprue Bushings

- $\frac{1}{8}$ " square M.I. cable
- Type J ungrounded thermocouple junction in the mid-section of the coil heater
- 48" of leads and 44" of SS armored cable Exit at 90°

Coil I.D.	Coil Width	Watts	Volts	OEM Part Number	TEMPCO Part Number
.500	4.625	300	120	SSTC-31-90	MHC00127
.500	4.625	300	240	SSTC-32-90	MHC00128
.500	2.500	450	240	SSTC-42-90	MHC00129

### For Gated, Flow Through Hot Sprue Bushings

- .110" x .160" rectangular or  $\frac{1}{8}$ " square M.I. cable
- No thermocouple
- 42" of leads and 38" of high temperature fiberglass sleeving

Coil I.D.	Coil Width	Watts	Volts	OEM Part Number	TEMPCO Part Number
1.250	2.625	800	240	SCH0001	HHC00001
1.250	1.750	600	240	SCH0002	HHC00002
.625	1.000	225	240	SCH0003	HHC00003
.750	1.750	315	240	SCH3142	HHC00004
.750	2.625	315	240	SCH3242	HHC00005

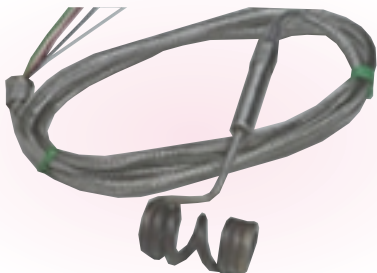

### For Heated Nozzle Locators

- $\frac{1}{8}$ " square M.I. cable
- Type J ungrounded thermocouple junction at tip of coil heater
- 36" of leads and 34" SS wire braid

Coil I.D.	Coil Width	Watts	Volts	OEM Part Number	TEMPCO Part Number
.500	1.450	250	240	SSTC-62-90	MHC00130
.500	1.950	250	240	SSTC-72-90	MHC00131



# Coil and Cable Heaters

## OEM Replacement Heaters

**STOCK ITEMS**  
**ORDER NOW!**

Tempco Replacement Heaters for externally heated manifold systems with **.250" Diameter Flow Path Nozzle Assemblies**. The coil heaters are .110" x .160" rectangular M.I. cable with ungrounded Type J thermocouple, 36" leads and 34" high temperature fiberglass sleeving for protection.

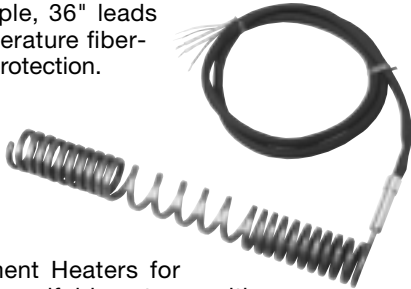

Coil I.D.	Coil Width	Watts	Volts	OEM Part Number	TEMPCO Part Number
.625	2.000	300	240	SCH0081	MHC00132
.625	2.500	350	240	SCH0082	MHC00133
.625	3.000	400	240	SCH0083	MHC00134
.625	3.500	425	240	SCH0084	MHC00135
.625	4.000	500	240	SCH0085	MHC00136
.625	5.000	500	240	SCH0086	MHC00137
.625	6.000	550	240	SCH0087	MHC00138

Tempco Replacement Heaters for externally heated manifold systems with **.375" Diameter Flow Path Nozzle Assemblies**. The coil heaters are .110" x .160" rectangular M.I. cable with ungrounded Type J thermocouple, 36" leads and 34" high temperature fiberglass sleeving for protection.

Coil I.D.	Coil Width	Watts	Volts	OEM Part Number	TEMPCO Part Number
.875	2.125	400	240	SCH0088	MHC00139
.875	2.625	450	240	SCH0089	MHC00140
.875	3.125	550	240	SCH0090	MHC00141
.875	3.625	700	240	SCH0091	MHC00142
.875	4.125	800	240	SCH0092	MHC00143
.875	5.125	900	240	SCH0093	MHC00144
.875	6.125	1000	240	SCH0094	MHC00145
.875	7.125	1100	240	SCH0095	MHC00146

### Tempco Replacement Heaters and Thermocouples for OEM Hot Runner Nozzles

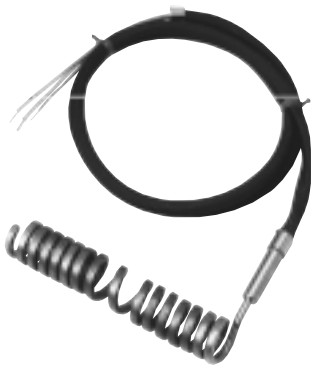

**STOCK ITEMS**  
**ORDER NOW!**

**STOCK ITEMS**  
**ORDER NOW!**

Coil I.D.	Coil Width	Watts	Volts	Part Number		Thermocouple	
				OEM	TEMPCO	OEM	TEMPCO
.750	1.437	250	240	SCH0060	HHC00006	TCG0060	TCR00017
.750	1.937	300	240	SCH0061	HHC00007	TCG0061	TCR00018
.750	2.437	350	240	SCH0062	HHC00008	TCG0062	TCR00019
.750	2.937	400	240	SCH0063	HHC00009	TCG0063	TCR00020
.750	3.437	425	240	SCH0064	HHC00010	TCG0064	TCR00021
.750	4.437	500	240	SCH0065	HHC00011	TCG0065	TCR00022
.750	5.437	500	240	SCH0066	HHC00012	TCG0066	TCR00023

SEE PAGE 10-14

**For Tubular Hot Runner Mold Heaters**

IN THE TUBULAR HEATER SECTION.

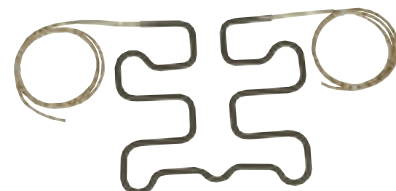



## Tempco Replacement Mini Coil Heaters (Round Cable) for OEM Hot Runner Systems

**Tempco's Mini Coil Band Heaters** are designed and manufactured under the tightest tolerances so that they may be used in hot runner/runnerless injection mold tooling with complete confidence on maintaining the manufacturer's original balanced heating when using a minimum of thermocouples and temperature control zones.

- ±2% Resistance Tolerance
- 5" and 7" Staggered Cold Lead Length
- 72" Insulated Lead Wire Length  
White/Black for 250W and White/Red for 125W

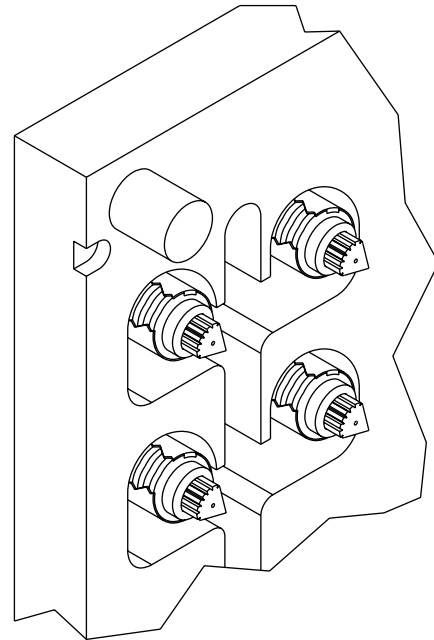

### Cam Operated Clamping

Cam operated axial clamping allows tool room personnel to replace the heating element or the thermocouple of the gate bushing without having to remove the bushing from the mold. This can even be done in emergencies while the mold is still in the press, saving hours of downtime. The hex head cam is accessed from the front, parallel to the bushing's shaft.



### Screw Clamping

Screw operated clamping for the traditional style.

### Specifications

#### Mechanical

- Coil Heater Diameter: .055", ±.002"
- Thermocouple: Type J, .055" dia., ±.002"
- Inner Diameter: ±.002"
- Width/Length: ±.020"
- Axial Clamp hex: Tempered 416 series SS  
Hex size: 1/8"  
Rotation: 150 degrees
- Clamp Screw: (2) 6-32 x 1/2", SS,  
Hex size 7/64"
- Heater Leads: 18 ga. silver coated copper, Teflon®  
insulation, 200°C/392°F.  
Staggered 5" and 7"
- Thermocouple leads: Fiberglass insulation, 1000°F

#### Electrical

- Resistance Tolerance: ±2%
- Wattage Tolerance: ±2%
- Voltage: Standard voltages are 120 and 240VAC;  
other voltages can be designed.  
*Consult Tempco with your requirements.*



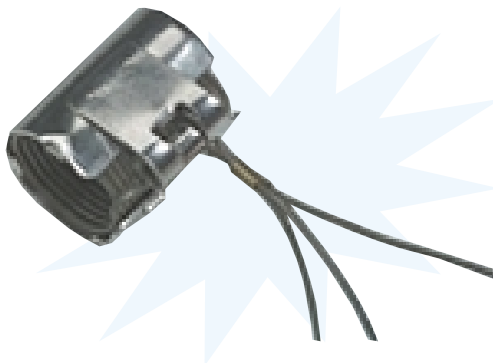

**STOCK ITEMS**  
**ORDER NOW!**

an asterisk next to the Part Number guarantees in-stock availability for same day shipping when **ORDERED BY 2<sup>PM</sup> CST**

### Cam Clamp Style Round Cable with Thermocouple — Standard Sizes and Ratings

Clamp Style	ID		Length		Watts	Volts	Part Number Heater Only	Part Number With Type "J" T/C
	in	mm	in	mm				
Axial	.750	19.0	1.20	30.5	① 149	240	*HRN00100	*HRY00110
	.750	19.0	1.20	30.5	② 268	240	*HRN00101	*HRY00111
	.750	19.0	1.75	44.4	250	240	HRN00102	HRY00112
	.750	19.0	2.00	50.8	313	240	HRN00103	HRY00113
	.875	22.2	1.75	30.5	250	240	HRN00104	HRY00114
	1.000	25.4	1.20	30.5	300	240	HRN00105	HRY00115
	1.000	25.4	2.00	25.4	313	240	HRN00106	HRY00116
	1.000	25.4	1.20	30.5	350	240	HRN00107	HRY00117
	1.000	25.4	2.00	50.8	440	240	HRN00108	HRY00118
	.500	12.7	1.20	31.7	120	240	HRN00109	HRY00119
Screw	.750	19.0	1.20	30.5	① 149	240	*HRN01100	*HRY01113
	.750	19.0	1.20	30.5	② 268	240	*HRN01101	*HRY01114
	.750	19.0	2.50	63.5	300	240	HRN01102	HRY01115
	.875	22.2	1.20	30.5	② 268	240	*HRN01103	*HRY01116
	.875	22.2	2.00	50.8	250	240	HRN01104	HRY01117
	.875	22.2	1.75	44.4	350	240	HRN01105	HRY01118
	.750	19.0	1.20	30.5	400	240	HRN01106	HRY01119
	.750	19.0	2.00	50.8	250	240	HRN01107	HRY01120
	.750	19.0	2.00	50.8	400	240	HRN01108	HRY01121
	.750	19.0	1.20	30.5	175	240	HRN01109	HRY01122
	1.500	38.1	2.50	63.5	610	240	HRN01110	HRY01123
	1.750	44.4	1.75	44.4	450	240	HRN01111	HRY01124
	2.500	63.5	1.50	38.1	380	240	HRN01112	HRY01125

① It is the hot runner industry practice to refer to this heater as 125W even though the actual wattage will be dependent on the applied voltage. The resistance is 386.58 ohms.

② It is the hot runner industry practice to refer to this heater as 250W even though the actual wattage will be dependent on the applied voltage. The resistance is 214.98 ohms.

Tempco P/N	OEM P/N	Rosemount P/N
HRN00100	534234	904FE101
HRN01100	520156	904EJ101, 904EN101, 904FB101

Tempco P/N	OEM P/N	Rosemount P/N
HRN00101	534233	904FE131
HRN01101	521334	904EJ131, 904EN131, 904FB131
HRN01103		904EJ141, 904EN141, 904FB141

### How to Order

#### Stock Heaters

Select a Mini-Coil Heater from the standard sizes and ratings list.

#### Custom Engineered/Manufactured Heaters

Understanding that an electric heater can be very application specific, for sizes, ratings and terminations not listed, **TEMPCO** will design and manufacture a Mini-Coil heater to meet your requirements. **Standard lead time is 3 weeks.**

**Please Specify** the following:

- Inner Diameter
- Width/Length
- Wattage
- Voltage
- Termination Type
- Cable/Braid Length
- Clamp Style
- Special Features



# OEM Replacement Heaters

## Tempco Replacement Coil Heaters for OEM Hot Runner Bushings — Standard Sizes and Ratings —

All OEM Replacement Heaters have round cable, Type "C" galvanized armor cable lead wire protection and LO2 lead orientation. See page 5-4.

Inside Diameter in	Outside Diameter in	Width in	Watts	Volts	Distributed Wattage	Close Wound	OEM Part Number	TEMPCO Part Number
1/2	0.808	3	380	240	yes		KH-52030	*MHC00005
1/2	0.808	3 1/2	380	240	yes		KH-52035	*MHC00006
1/2	0.764	4 1/2	400	240	yes		KH-53545	MHC00008
1/2	0.750	5 1/2	400	240	yes		KH-53555	*MHC00009
1/2	0.750	6 1/2	400	240	yes		KH-53565	*MHC00010
1/2	0.764	2	340	120		yes	KH-520	*MHC00012
1/2	0.764	2 1/2	340	120	yes		KH-52025	*MHC00013
1/2	0.764	3	380	120	yes		KH-52030	*MHC00014
1/2	0.764	3 1/2	380	120	yes		KH-52035	*MHC00015
1/2	0.744	4 1/2	400	120	yes		KH-53045	*MHC00016
1/2	0.744	5 1/2	400	120	yes		KH-53055	*MHC00017
1/2	0.744	6 1/2	400	120	yes		KH-53065	*MHC00018
7/8	1.181	2 5/8	480	240	yes		KH-826	*MHC00043
7/8	1.181	3 1/4	480	240	yes		KH-82630	*MHC00044
7/8	1.181	3 5/8	550	240	yes		KH-82636	*MHC00050
7/8	1.181	4 1/8	550	240	yes		KH-82640	*MHC00051
7/8	1.181	5 1/8	650	240	yes		KH-82650	MHC00052
7/8	1.181	6 1/8	650	240	yes		KH-82660	MHC00053
7/8	1.181	7 1/8	650	240	yes		KH-82670	MHC00054
7/8	1.105	8 1/8	730	240	yes		KH-84380	*MHC00064
7/8	1.105	9 1/8	730	240	yes		KH-84390	*MHC00065
7/8	1.105	10 1/8	850	240	yes		KH-84310	*MHC00066
7/8	1.105	11 1/8	850	240	yes		KH-85311	*MHC00068
7/8	1.105	12 1/8	850	240	yes		KH-85312	*MHC00069
7/8	1.105	13 1/8	850	240	yes		KH-85313	*MHC00070
7/8	1.105	14 1/8	850	240	yes		KH-85314	*MHC00071
1 1/4	1.480	2 1/2	750	240		yes	KH-1225	*MHC00082
1 1/4	1.514	4 1/2	1250	240		yes	KH-1245	*MHC00083
1 1/4	1.534	6 1/2	1800	240		yes	KH-1265	*MHC00084
1 1/4	1.594	8 1/2	2335	240		yes	KH-1285	MHC00086
1 1/4	1.626	10 1/2	2500	240		yes	KH-12105	*MHC00087



**STOCK ITEMS**  
ORDER NOW!

an asterisk next to the Part Number guarantees in-stock availability for same day shipping when

**ORDERED BY 2<sup>PM</sup> CST**

### How to Order

#### Stock Heaters

Select a Coil Heater from the standard sizes and ratings list.

#### Custom Engineered/Manufactured Heaters

Understanding that an electric heater can be very application specific, for sizes, ratings and terminations not listed, **TEMPCO** will design and manufacture a Coil heater to meet your requirements. **Standard lead time is 3 weeks.**

**Please Specify** the following:

- Inner Diameter
- Width/Length
- Wattage
- Voltage
- Termination Type
- Cable/Braid Length
- Clamp Style
- Special Features