

LCU2 Series

Process Temperature Controller

INSTRUCTION MANUAL

Thank you for the purchase of LOVE CONTROLS product.
Please read this manual carefully.



LCU2 Series

High Accuracy 0.1 class 250ms



Features

- Fuzzy
- Auto Tuning
- Alarm Output
- Retransmission Output
- Multi Input • Output
- External Contact Input
- Ramp / soak
- Heating / Cooling
- Zone PID
- Group PID
- Power supply for sensor
- Output Limits
- Interface (RS485 / 422)
- 3 Set points
- Heater break alarms (HBA1, HBA2)
- IP65 Front facia

LOVE CONTROLS





CONTENTS

1. SAFETY INFORMATION -----	P. 3
2. INSTRUCTION -----	P. 5
3. ORDERING INFORMATION -----	P. 5
4. SPECIFICATION -----	P. 6
5. DIMENSIONS & PANEL CUTOUT ---	P. 10
6. TERMINAL ARRANGEMENT -----	P. 11
7. NAME & FUNCTION -----	P. 12
8. TABEL OF SETTING ITEMS -----	P. 13
9. SETTING METHOD -----	P. 15
10. CONTROL GROUP-----	P. 16
11. INPUT GROUP SETTING -----	P. 17
12. OUTPUT GROUP SETTING -----	P. 19
13. SET VALUE GROUP SETTING -----	P. 20
14. PROGRAM GROUP SETTING -----	P. 21
15. AUTO TUNING -----	P. 22
16. P.I.D GROUP -----	P. 23
17. ALARM GROUP SETTING -----	P. 24
18. RETRANSMISSION GROUP -----	P. 25
19. COMMUNICATION -----	P. 26
20. HEATER BREAK ALARM GROUP --	P. 27
21. REMOTE INPUT GROUP -----	P. 27



Before using, please read this (SAFETY INFORMATION) and then use this controller.
It is important that the instructions in this manual are followed when using this instrument.
Please keep this manual for future reference.
Precautions are classified in WARNING and CAUTION.

 WARNING	There is a possibility of death or heavy injury when handling in wrong way.
 CAUTION	There is a possibility of injury or physical damage when handling in wrong way.

WARNING

Caution on wiring

Use an external protection circuit if a fault in the control loop could possibly lead to a serious problem.

This instrument do not have a switch for power and a fuse, so please set them if it is needed.

(Fuse rating 250V, 0.5A)

Power supply

Use a rated voltage to prevent damage or trouble.

To avoid electrical shock or damage, do not turn ON the power until the wiring is completed.

Prohibit use in gas atmosphere

Do not use it at a place exposed to combustibile or explosive gas.

Handling of unit

To avoid malfunction, electrical shock or fire, this unit must not be disassembled or repaired.

Do not touch the terminals to avoid electrical shock or malfunction.

Caution on maintenance

Turn OFF the power before mounting or removing the instrument.

To ensure continuous and safe operation of the instrument, periodical maintenance is recommended. Some parts are limited in life.

The warranty period is 1 year only if using in the correct way.

CAUTION

Caution on handling

 Do not install the instrument under any of the following conditions.

The ambient temperature exceeds 0 ~ 50

The ambient humidity exceeds 45 ~ 85%RH.

A place where temperature changes suddenly or icing occurs.

A place exposed to corrosive gas or combustibile gas.

Vibration or shock is likely to be transmitted to the instrument.

A place exposed to water, oil, chemicals, steam, sunlight.

A place exposed to much dust, salt or iron.

A place with much inductive disturbance, static electricity, magnetism noise.

A place where heat such as radiant heat stays.

Installation

Attach the brackets (2 units) on the fixed halls and tighten with a screwdriver.

Fixing torque is about 147N. cm (1.5kg.cm)

(Care should be taken not to tighten forcedly)

Caution on terminal connections

To avoid induction noise to input wires separate from the power and output wires.

Keep input wires away from output wires and use shielded wires to earth.

Use a compensating cable with thermocouple.

For R.T.D input use a cable which is a small lead wire resistance and without resistance difference to 3 wires.

If the wiring has noise, use the following step: connect a surge absorber to the conductor coil side if the conductors are connected to the load output, such as the relay contact output.

(EX. For AC 220V ENC 471D-05A)

Use an insulating transformer with a noise filter when the power supply has much noise.

(EX. TDK brand ZMB 22R5-11 noise filter)

Noise filter should be mounted on a panel which has been earthed and the wiring between the noise filter output and the instrument power terminals should be shorten.

It is effective to use a twisted cable for power supply against noise.

The heater power supply and the instrument power supply should be connected using the same power supply when a heater break alarm.

Time for preparation of contact output is required at power ON. When the output signal is used for an external interlock circuit, connect a delay relay.

For load circuit connection

Use an extra relay when the frequency of operation is rather high.

SSR output type is recommended.

- Electromagnetic switch : Proportional cycle time is Min. 30sec
- SSR : Proportional cycle time is Min. 1 sec
- Contact output life : Mechanical : 10 million times (no load)
Electrical : 100 thousand times (rated load)
- SSR drive pulse voltage, DC 4~20mA are not insulated with internal circuit.
Use non-grounded sensor to R.T.D and thermocouple.

For waterproof (Waterproof type)

The instrument has IP65. Use rubber packing when installing the instrument to panel.

Please attach the rubber in correct way.

Caution on key operation / trouble

If alarm function is not set correctly, alarm output can not be operated at a trouble point.

Be sure to check the alarm operation.

If the input cable is disconnected, the display shows " *boUt* ".

When replacing the sensor, please turn OFF the power supply.

Other

Do not use organic solvents such as alcohol, benzene when cleaning. (Use neutral detergent)

2

INSTRUCTION

This instrument has process-value (PV) and set-value (SV) each 4 digits with 7 segment FND. This instrument is available in 2 versions: Universal Type and Heating / Cooling Type. Each has 12 Setting groups (refer pages 9 & 10)

Function and feature : Group P.I.D, Multi-input (19 types), Multi-output (Relay, SSR, Current), Local input, Remote input, External contact input, Program Control (Ramp / Soak) with 10 steps, Auto-tuning 2 types (standard type, low PV type), Manual output, Retransmission, Communication (RS485 / 422), Power supply for sensor, 22 types of alarm, Sampling cycle 250ms, 0.1% FS high accuracy.

3

ORDERING INFORMATION

LCU208 - 𠄎

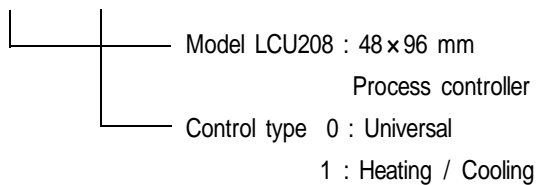

LCU204 - 𠄎 𠄎

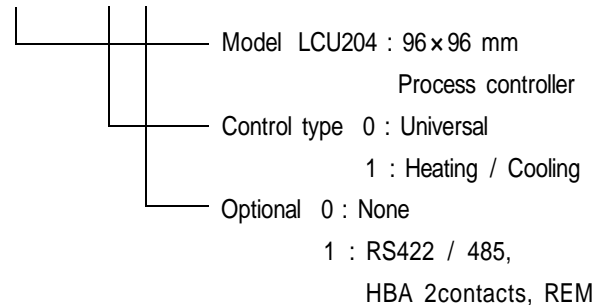

LCU209 - 𠄎

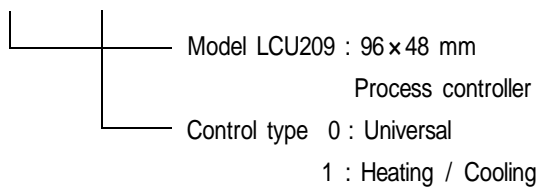

- Input : Thermocouple, R.T.D, Direct voltage
(refer to the input signal and measurement range on page 18)
 - Sampling cycle time : 250 ms
 - Input resolution : Below decimal point of range
 - Input impedance
Thermocouple / Voltage (mV) input : 1M or above
Voltage input (V) : Approx. 1M
 - Allowable signal source resistance
Thermocouple : 250 or below
Voltage input : 2k or below
 - Allowable wiring resistance
R.T.D : 150 or below / 1 wire
 - Allowable input voltage
Thermocouple, R.T.D, Direct voltage (mV) : $\pm 10V$
Direct voltage (V) : $\pm 20V$
 - Noise ratio
NMRR :40dB or above
CMRR :120dB or above (50/60Hz $\pm 1\%$)
 - Standard : Thermocouple / R.T.D (KS / IEC / DIN)
 - Standard junction temperature compensation tolerance : ± 1.5 (15 ~ 35)
 ± 2.0 (15 ~ 50)
 - Burn-out detection : OFF, Up / Down scale selectable
Thermocouple burn-out : Up / Down scale
R.T.D burn-out : Up scale
(TC / R.T.D burn-out detection current : Approx. 50nA)
 - Accuracy : 0.1% of F.S
- Power supply
Power supply voltage : 100-240V~, 24V
Frequency : 50/60Hz
Voltage variation : -10% +10%
Power consumption : Max. 6.0W, 10VA or below
Power supply for sensor : 27V - 20mA
(but, it is not available when using retransmission output)
- Insulation resistance : 20M Ω min. (at 500VDC)
Between primary terminal and secondary terminal
Between primary terminal and ground
Between ground and secondary terminal
- Dielectric strength : 2300V AC 50/60Hz for 1 minute
Between primary terminal and secondary terminal
Between primary terminal and ground
Between F.G and secondary terminal : 1500V AC 50/60Hz for 1 minute

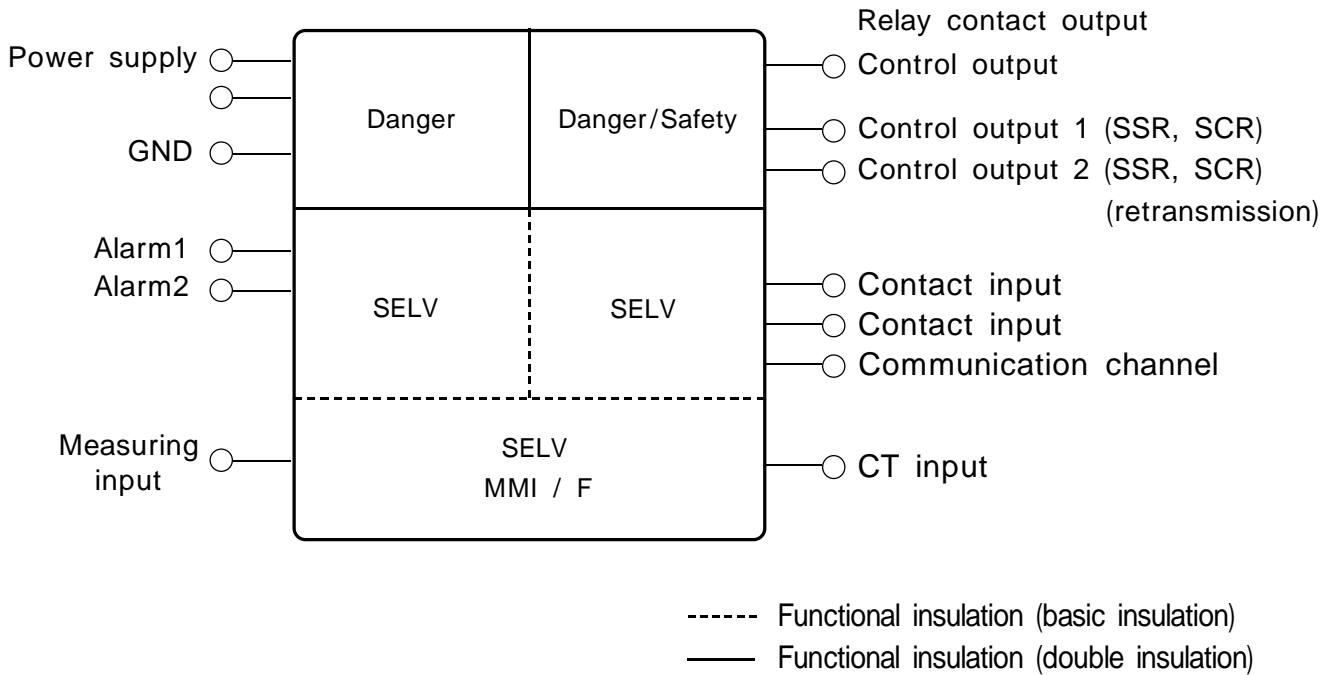

Output

Relay contact output

Contact capacity : 240V AC 3A, 30VDC 3A (Resistance load)

Contact structure : 1c

Output action : Propotional or ON / OFF action

Proportion cycle time : 1 ~ 1000 sec.

Output limit : Higher (OH) or lower limit (OL) selectable within 0.0 ~100.0% range

It is also available in Auto tuning

ON / OFF hysteresis : 0~100%

Time resolution : 0.1% or 10ms

SSR output

ON voltage : 12V DC min. (Resistance load : 600 min, 30mA limit when short)

OFF voltage : 0.1V DC max.

Output action : Proportional action

Proportion cycle time : 1 ~ 1000 sec.

Output limit : Higher (OH) or lower limit (OL) selectable within 0.0 ~100.0% range

It is also available in AT and MAN.

Time resolution : 0.1% or 10ms (whichecker is larger)

Current output

Output current range : 4 ~ 20mA DC

Resistance load : 600 max.

Accuracy : ±0.3% of F. S (4 ~ 20mA) Resolution : Approx. 3000

Output ripple : 0.1% of F. S (p-p) 150Hz

Output update cycle time : 250m sec.

Output action : P.I.D control

Output limit : Higher (OH) or lower limit (OL) selectable within -0.5 ~ 105.0% range

It is also available in AT and MAN.

Manual operation

It is changeable by A/M key, external contact and communication.

AT † MAN : TRACKING

MAN † AT : BUMPLESS CONVERSION

Retransmission output

Current output

Output current range : 4 ~ 20mA DC

Resistance load : 600 max.

Accuracy : $\pm 0.3\%$ of F. S (4~20mA)

Resolution : Approx. 3000

Output ripple : 0.1% of F. S (p-p), 150Hz

Output update cycle time : 500msec (When remote option)

Alarm output (HBA common)

Output : Relay contact

Output contact : 3 points

Contact capacity : 240V AC 1A , 30V DC 1A (Resistance load)

Contact structure : 1a

Communication Interface

Standard : EIA RS485

Number of devices (Max.) : 31, Address setting : 1~99 range

Communication type : 2-wire or 4-wire half-duplex

Synchronization : Asynchronous

Communication order : None

Communication distance : Max. 1200m

Communication rate : 600, 1200, 2400, 4800, 9600

Start Bit : 1Bit

Data length : 7 or 8 Bit

Parity : None, Even, Odd

Stop Bit : 1 or 2 Bit

Protocol : PC LINK

Response time : Handling time + (RP.T \times 10ms)

Heater break alarm

Output contact : 2 points

Current measurement range : 1~50A AC (Resolution 0.5A, $\pm 5\%$ of F.S ± 1 Digit)

Alarm output : AL1, 2 output

It is available to use in ON / OFF or proportional action. (not available in current or cooling output)

Minimum detection time : 0.2 sec

Dead Band : 0 ~ 100%

SAFETY AND EMC STANDARDS

Safety standards: IEC1010-1-1990 and EN61010-1-1992; CSA1010 CAT (IEC1010-1); and UL508.

EMC Standards: EN55011 Class A, Group 1, for emission (EMS); and EN50082-2-1995 for immunity(EMI).

The indicator continuously operates within a measuring accuracy of $\pm 20\%$ of the range.

EN61000-3-2, EN61000-3-3

Ambience

[Installation Conditions (for normal operation)]

Ambient temperature : 0 ~ 50

Ambient humidity : 20 ~ 90%RH (No condensation)

Installation place : Indoors

Magnetic effect : 400 AT/m max.

Vibration : 5 ~ 14Hz, forth width 1.2mm max.

4 ~ 150Hz, 4.9m/s² (0.5G) max.

Shock : 147m/s²(15G), 11msec max.

Height : 2000m max.

Installation category : (EN61010-1)

Pollution degree : (EN61010-1)

Storage temperature : -25 ~ 70

Storage humidity : 5 ~ 95%RH

Case : Plastic

Weight :

PX 2	PX 3	PX 9
342 g	340 g	472 g

Including brackets (Brackets 40g)

1) LCU208 (48 × 96mm)

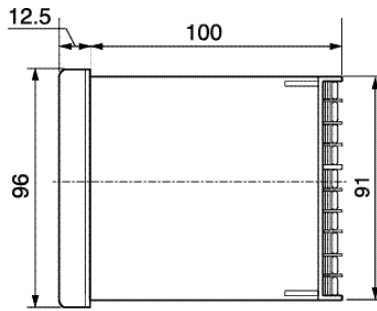
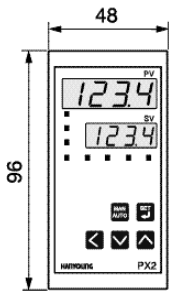

Panel cutout

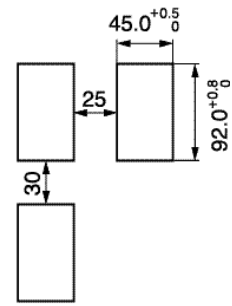

(Unit : mm)

2) LCU209 (96 × 48mm)

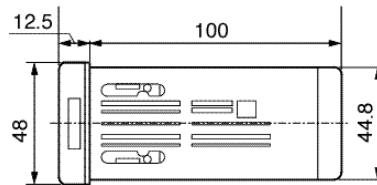
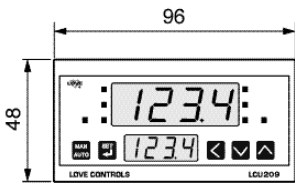

Panel cutout

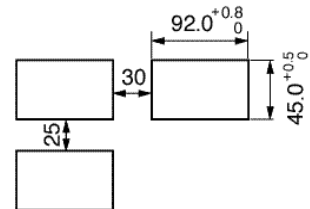

(Unit : mm)

3) LCU204 (96 × 96mm)

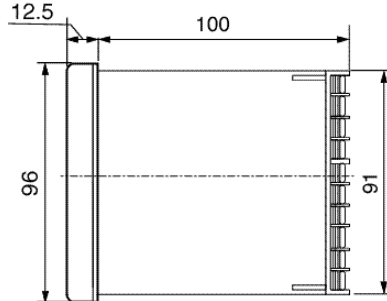
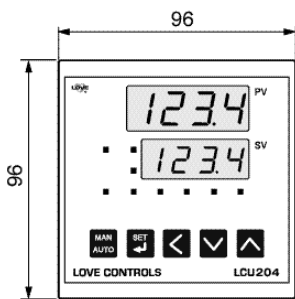

Panel cutout

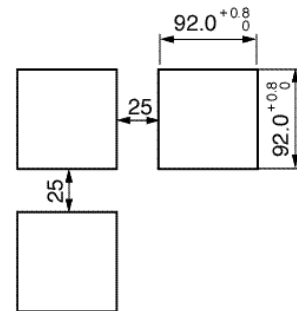

(Unit : mm)

4) CURRENT TRANSFORMER (Model: CTL-6-S)

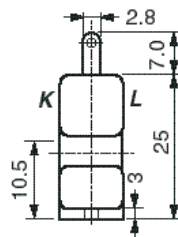
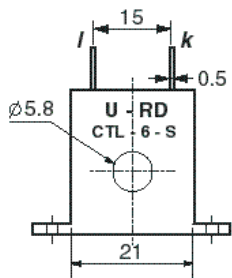

Panel cutout

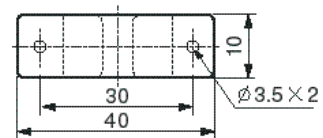

(Unit : mm)

1) LCU208 (48 x 96mm)

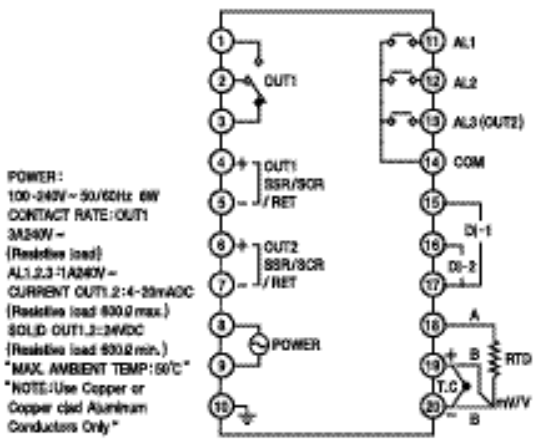

2) LCU209 (96 x 48mm)

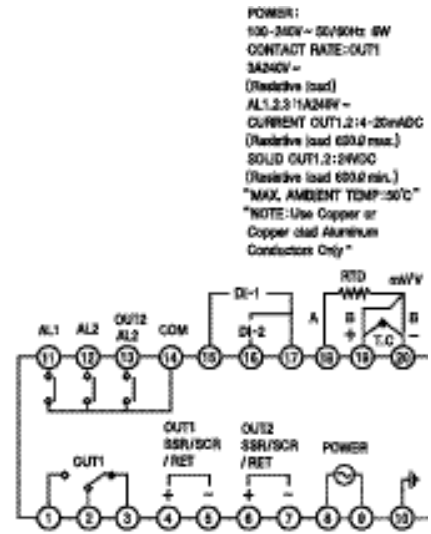

3) LCU204 (96 x 96mm)

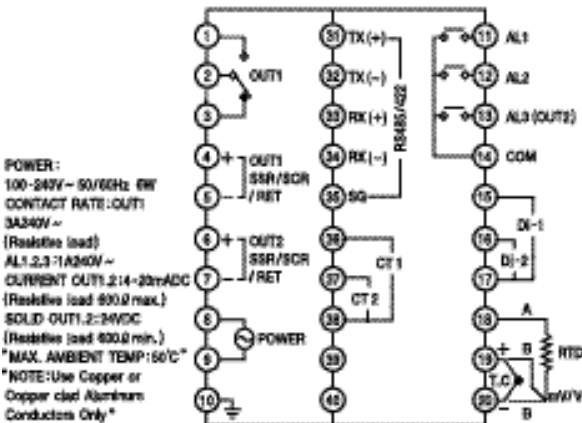



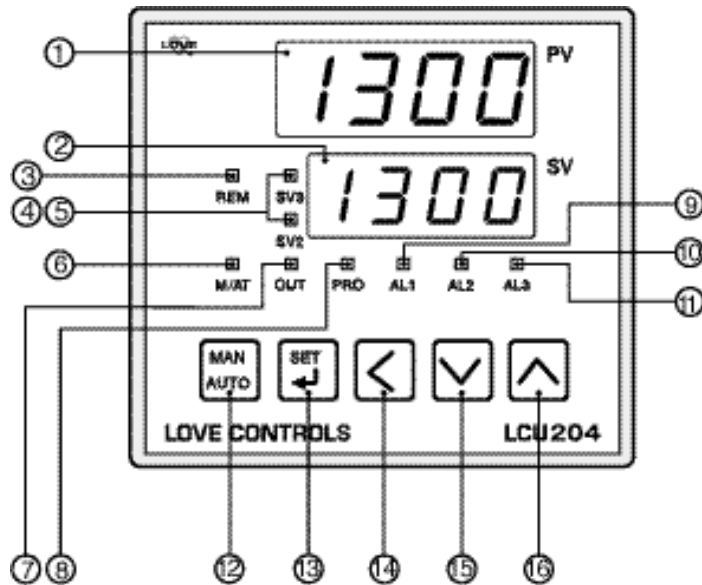

[Note] Heater break alarm is used by setting alarm outputs (AL1,AL2,AL3)



Displays

Name of respective parts	Functions
Process-value (PV)	Displays the process temperature value.
Set-value (SV)	Displays various set - value, message, and parameter.
Remote indicator	Lights when the remote operation.
Set-value display indicator	Lights when the SV2 or SV3 is displayed.
Manual /Auto tuning indicator	This lamp lights when Manual control.(It does not light for AT)
Output indicator	Lights when the control output is ON.
Program display indicator	Lights during program operation.
Alarm 1 indicator	Lights when the alarm 1 operates.
Alarm 2 indicator	Lights when the alarm 2 operates.
Alarm 3 indicator	Lights when the alarm 3 operates.

Control key

Key	Functions
	Used to select Auto or Manual control.
	Used to change from the operation mode to the setting mode, to select parameters, and to register set-value. Press this key for 3 sec to display setting mode, set-value, and process value.
	Used to select digit for changing.
	Used to decrease set-values and to select setting mode.
	Used to increase set-values and to select setting mode.

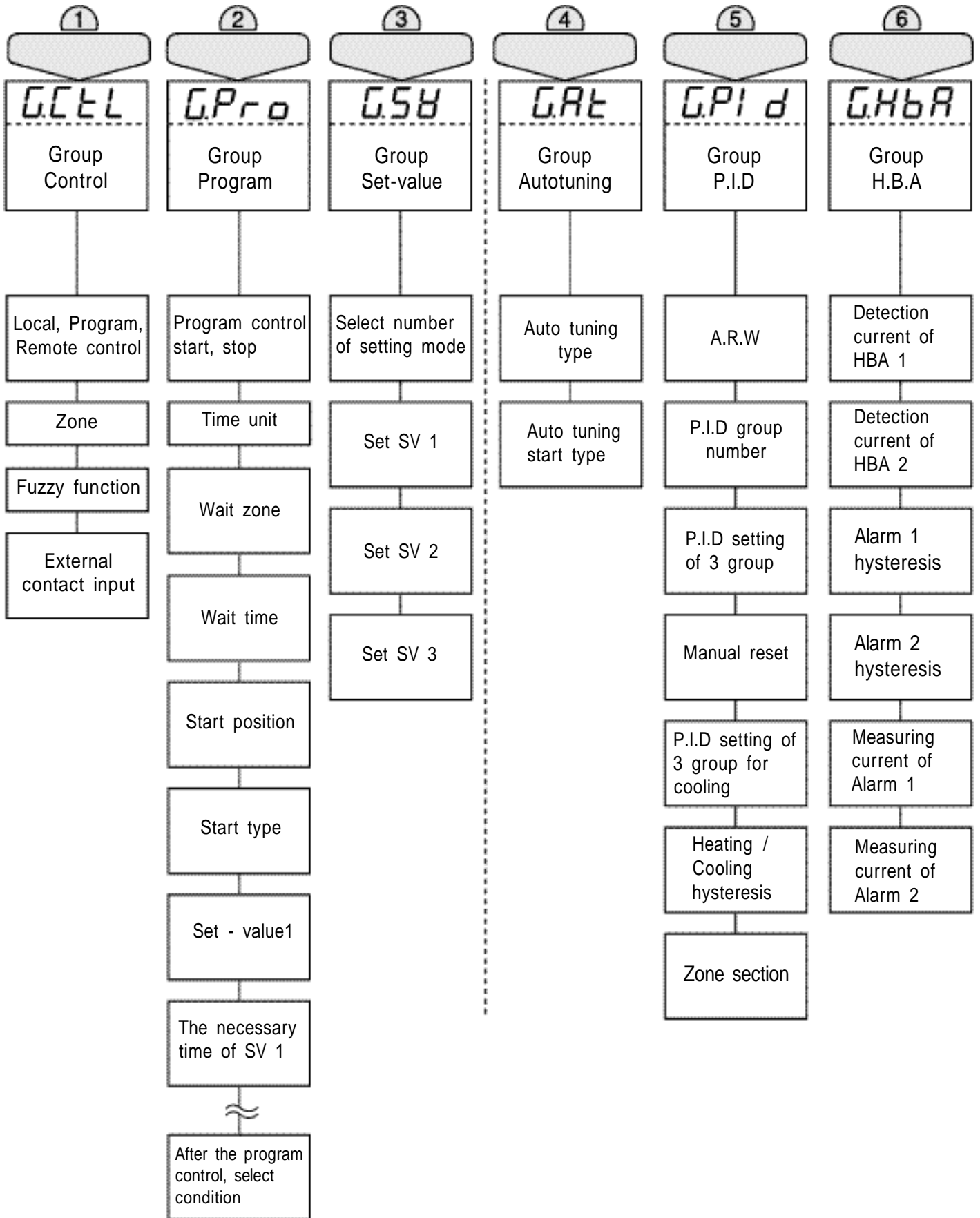

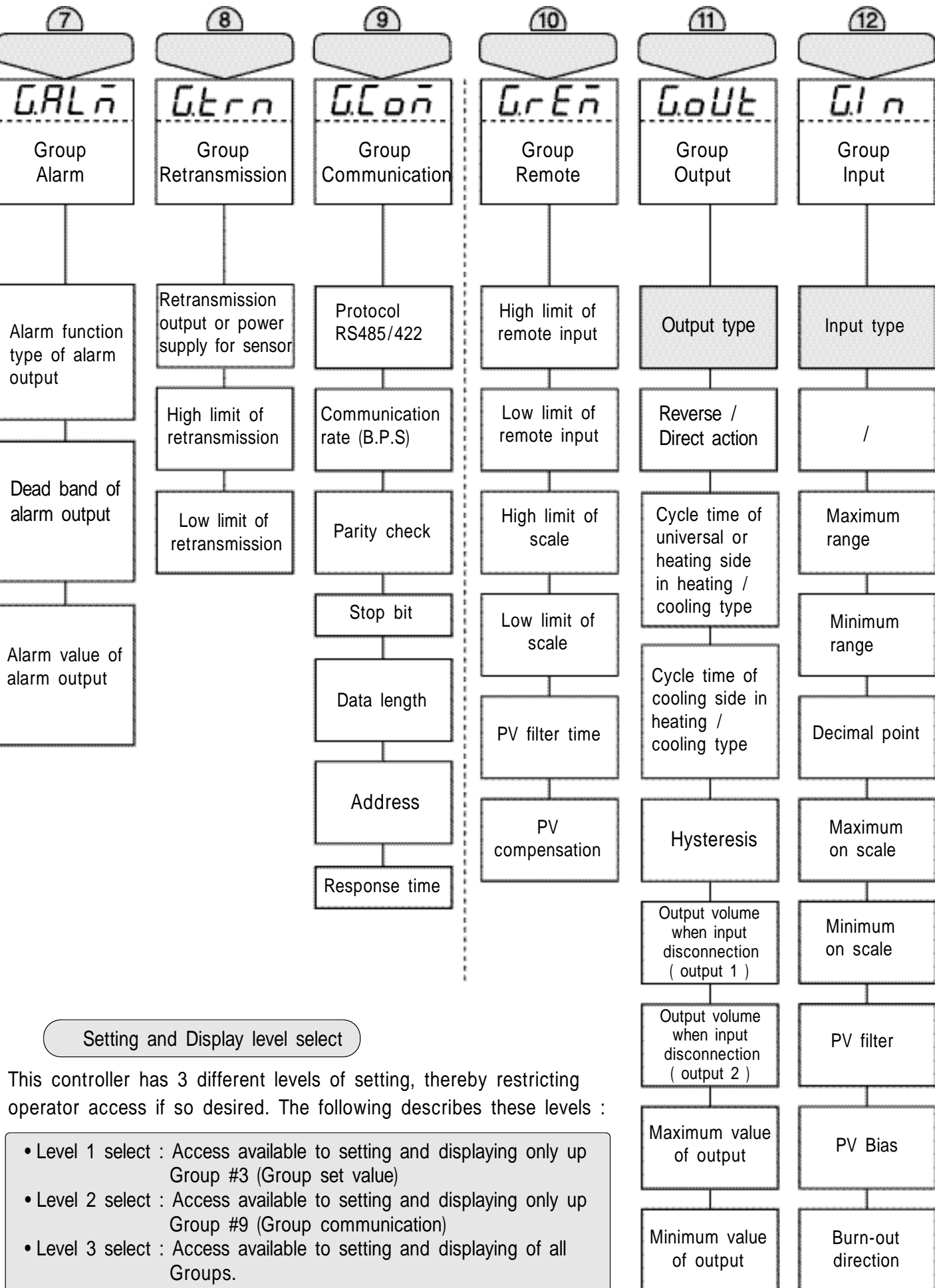

Setting and Display level select



This controller has 3 different levels of setting, thereby restricting operator access if so desired. The following describes these levels :

- Level 1 select : Access available to setting and displaying only up Group #3 (Group set value)
- Level 2 select : Access available to setting and displaying only up Group #9 (Group communication)
- Level 3 select : Access available to setting and displaying of all Groups.

AFTER COMPLETION OF WIRING, APPLY POWER ON _____

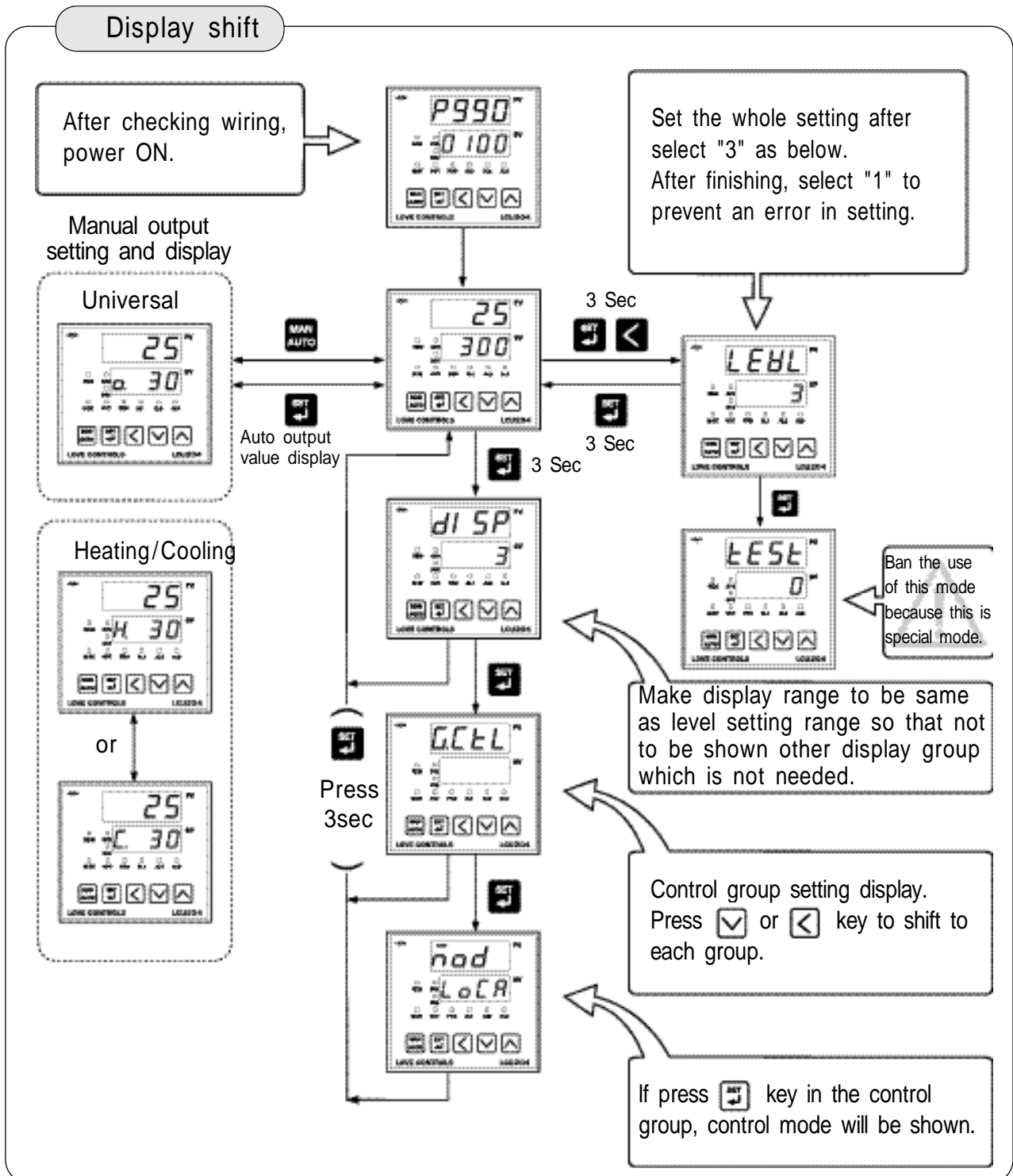
- (1) Production Model Code will be indicated as in _____ below, followed by current PV and SV values, as in _____ below.
- (2) For setting a level, press and at a time for 3 sec. to enter **LEHL** (LEVEL) setting mode. (Level 3 is set at the factory)
- (3) In the _____ condition, press for 3 sec to enter **DISP** (display) selection mode. (This mode is limited by level setting mode _____)
- (4) In the _____ conditon, press to set manual output value regardless auto operation data and press to indicate an auto output value.



Local, Program or Remote is selected in the control group mode using  or  key.

When selecting LOCAL mode, control zone selection and fuzzy function selection are available.

Control zone selection is not available when selecting program mode or remote mode.

Fuzzy function is operating in the P.I.D control. (not operating in the ON/OFF control)

Using two external contact input (DI) as ON/OFF, it is possible to control 3 kinds setting values and Auto operation or Manual operation is selectable in the start, reset, local mode.



DIS selection	External input signal		Functions
OFF	Initial value is OFF (None)		
1	DI-1	OFF	SV 1 display and selection
		ON	SV 2 display and selection
	DI-2	OFF	Auto control
		ON	Manual control
2	DI-1	ON	Start (Program control)
		OFF	Reset (Program control)
3	DI-1	OFF	SV 1 display and selection
	DI-2	OFF	
	DI-1	OFF	SV 2 display and selection
	DI-2	ON	
	DI-1	ON	SV 3 display and selection (When DI-1 and , DI-2 are ON, it is same)
	DI-2	OFF	

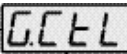
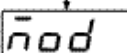
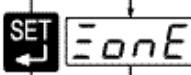
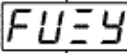
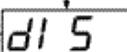



(Chart1)

Signal	Name	Operation	Display condition	Initial Value
	Control group display	Set a control mode	—	—
	control mode selection	LOCA / PROG / REM	Always display	LOCA
	Zone selection 雫1	OFF / ON	When local mode selection	OFF
	Fuzzy function selection	OFF / ON	When P.I.D control	OFF
	External contact input selection	(Refer to chart 1) OFF / 1 / 2 / 3	Always display	OFF

雫 1 : This signal is not indicated in Program or Remote operation.
Zone P.I.D will be operated.

Input type selection

After power ON and when PV is indicating, press  key for 3 sec to be displayed  at PV and 3 at SV. (If it is not indicated 3, set again in the level setting mode)

Control group is indicated when press  key once more. At the time, input group is indicated when press  key and then "Input type and range selection" is shown at SV when press . At this time the input and range is selected by  or  key.

CAUTION





When setting, "Input type selection number" must be selected in the input type selection mode and also "Output type selection number" must be selected in the output type selection mode before moving to other mode.

If not, data of other group will be changed to prior value.

Display unit (/)

After selecting input type and range, press  key to select display unit. Press  key to choose or and press  key when finishing selection.

Maximum and Minimum range

After selecting display unit, press  key to set Maximum and Minimum range using  or  key. Press  key once more to finish.

Decimal point

Parameter is not indicated in T.C and R.T.D input, but when selecting voltage input (code 30,32,33), "Decimal point" mode is indicated. (set 1 : 0.0, set 2 : 0.00, set 3 : 0.000)

Maximum and Minimum on scale

It is the same function as Maximum and Minimum range setting when R.T.D or thermocouple input. This mode is indicated when voltage input (30, 32, 33)



PV filter

When PV value becomes unstable due to effects of noise, the filter helps suppress the unstable status. (Range: OFF or 1~120sec. Initial value: OFF)

PV bias

Use this function to adjust PV value in cases where it is necessary for PV value to agree with another recorder or indicator, or when the sensor cannot be mounted in correct location.

(Range : -100.0~100.0% of SPAN, Initial value : 0.0%)

Setting a value using  or  key and press  key to finish.

Signal	Name	Description	Condition	Initial value
	Input group	Input type and mode selection	—	—
	Input signal selection	Refer to input signal and range	Always	Selection NO.1
	Measurement range unit	/	Thermocouple or R.T.D	
	High limit	Refer to input signal and range	Always	1370
	Low limit	(Notice : FR-H > FR-L)	Always	-200
	Decimal point	Thermocouple or R.T.D : decimal point of instrument / DC Voltage : 0~3	On voltage input (mV,V)	1
	Maximum on scale (on voltage input)	-1999~9999	On voltage input (mV,V)	100.0
	Minimum on scale (on voltage input)	Notice : SL-H SL-L Deimal point : according to DP-P		0.0
	PV filter	OFF/1~120sec	Always	OFF
	PV bias	EUS (-100.0~100.0%)	Always	EUS(0.0%)
	Burn-out	OFF / UP / DOWN	Always	UP

INPUT SIGNAL AND MEASUREMENT RANGE

Input code	Input signal	Range ()	Range ()	Accuracy	Remarks	
1	K § 2	-200~1370	-300~2500	±0.10% of F.S ±1digit	F.S is maximum value of each RANGE	
2	K § 2	-199.9~999.9	0~2300			
3	J § 2	-199.9~999.9	-300~2300			
4	E § 2	-199.9~999.9	-300~1800			
5	T § 2	-199.9~400.0	-300~750			
6	R § 2	0~1700	32~3100	±0.15% of F.S ±1digit		
7	B § 1	0~1800	32~3300			
8	S	0~1700	32~3100			
9	L § 2	-199.9~900.0	-300~1300	±0.10% of F.S ±1digit		§ 1 0~400 : ±5% of F.S ±1digit § 2 0 and below : ±0.2% of F.S ±1digit § 3 -150.0~150.0 : ±0.2% of F.S ±1digit
10	N	-200~1300	-300~2400	±0.20% of F.S ±1digit		
11	U § 2	-199.9~400.0	-300~750	±0.10% of F.S ±1digit		
12	W	0~2300	32~4200			
13	Platinel	0~1390	32~2500			
20	JPt100 § 3	-199.9~500.0	-199.9~999.9	±0.10% of F.S ±1digit		
21	Pt100 § 3	-199.9~640.0	-300~1180			
30	1.000~5.000V	1.000~5.000V		±0.10% of F.S ±1digit		
32	-10.00~20.00mV	-10.00~20.00mV				
33	0.0~100.0mV	0.0~100.0mV				

Current input : The current input (DC4~20mA) is available with input code 30.

You must use the resistance 250 (0.5W / 0.1%) on input terminals.

12 OUTPUT GROUP SETTING

This process controller is divided into 2 types: UNIVERSAL TYPE AND HEATING / COOLING TYPE. Output is selectable from Relay, SSR, and Current (4~20mA DC).

Output type range (output code) is 0 ~ 3 for universal type and 4 ~ 12 for Heating /Cooling type. Sometimes retransmission output and alarm output are not available according to control output (EX. When you choose output code (OT) 2, it is current output of Universal type. In this case, retransmission output and alarm output are available. But, In Heating / Cooling control type with SSR on Heating side and Relay output on Cooling side (output code 3), the retransmission output is available but alarm output 3 is not available.

⚠ CAUTION

When setting, “Input type selection number” must be selected in the input type selection mode and also “Output type selection number” must be selected in the output type selection mode before moving to other mode.

If not, data of other group will be changed to prior value.

Signal	Name	Description	Condition	Initial value
	Output group	Output type and mode selection	—	—
	Output signal	Refer to type of control output	Always	(3 / 12)
	Output operation	REV: Reverse DIR: Direct action	Output code 1~3	REV
	Cycle time	1~1000 sec	Relay / SSR	30 sec
	Cycle time of cooling output	1~1000 sec	Output code 4~12	30 sec
	Hysteresis of univesal type	EUS(0.0~100.0%)	ON/OFF Control	EUS(0.5%)
	Hysteresis of Heating/Cooling type	0.0~10.0%	Heating/Cooling	0.5%
	Output volume when input disconnection Output 1 (Out1)	Universal : -5.0~105.0% Heating / Cooling : 0.0~105.0%	Always	0.0%
	Output volume when input disconnection Output 2 (Out2)	0.0~105.0%	Heating / Cooling	0.0%
	Maximum value	Universal : OL-L + 1Digit~ 105.0% Heating / Cooling : 0.0~ 105.0%	PID Control	100.0%
	Minimum value	Universal : -0.5%~ OL-H-1Digit Heating / Cooling : 0.0~ 105.0%	PID Control	0.0 % 100.0%

Type of control output (Universal type)

Model	Output code (O T)	OUT1		OUT2
		Relay	SSR / Current	SSR / Current / Retransmission
PX9-0 PX3-0 PX2-0	0	Relay ON / OFF		Retransmission
	1		SSR	Retransmission
	2		Current	Retransmission
	3	Relay		Retransmission

Type of control output (Heating / Cooling type)

Model	Output code (O T)	Heating (OUT1)		Cooling (OUT2)	
		Relay	SSR / Current	Relay	SSR / Current / Retransmission
PX9-0 PX3-0 PX2-0	4		SSR		SSR
	5		Current		SSR
	6	Relay	Retransmission		SSR
	7		SSR		Current
	8		Current		Current
	9	Relay	Retransmission		Current
	10		SSR	Relay(AL3)	Retransmission
	11		Current	Relay(AL3)	Retransmission
	12	Relay		Relay(AL3)	Retransmission

13 SET VALUE GROUP SETTING

Set value group is indicated with selecting Local mode or Remote mode in GROUP CONTROL (Not Program mode). “ Select number of SV ” is after setting 3 type of set value in Local mode, select each set value from external contact input to operate. After selecting number of set value, press  key, you could set set-value of SV1, SV2, and SV3.

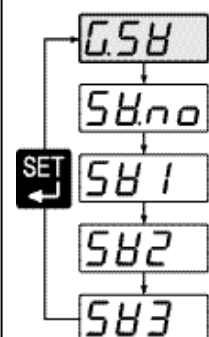
Signal	Name	Description	Condition	Initial value
	Set value group	Set value setting	—	—
	Select number of set value	1~3	REM / LOCA	1
	Set SV 1	EU(0.0~100.0%)	REM / LOCA	EU(0.0%)
	Set SV 2	EU(0.0~100.0%)	REM / LOCA	EU(0.0%)
	Set SV 3	EU(0.0~100.0%)	REM / LOCA	EU(0.0%)

 EU : Value at an engineering unit in compliance with the range of an instrument.

If Program mode is selected in Group Control, the controller becomes a programmable (ramp/ soak) controller with 1 pattern of 10 step. After setting time and set value, this controller controls automatically.

A pattern is a series of steps. Each step consists of a SV and time setting.

An Increasing or decreasing SV is set for time period, and each time setting is in hours/ minutes or minutes/ seconds.

After wiring, check and power ON. PV and SV will be indicated.

At this time, press key 3sec. to enter (display) in PV and then press key once more to get Group Control (SV is off).

At this condition, press key to get control mode(Mod) in PV and select program (PROG) in SV using or .

Press key once more to set program and then press key 3 times to get group control (G: CTL) in PV (SV is off). And then press key to be indicated program group as below.

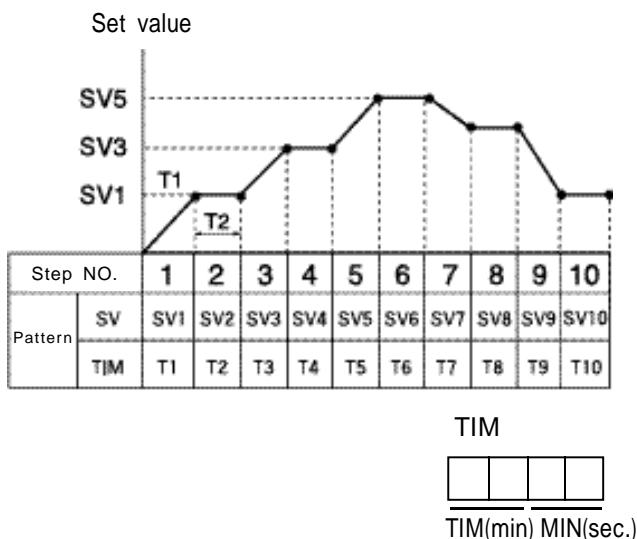

Signal	Name	Description	Condition	Initial value
	Program group	—	—	—
	start / Reset selection	OFF: Reset / ON: Start	PROG	OFF
	Time unit	H.MN: 99H 59min. M.SEC: 99M 59sec.	PROG	M.SEC
	Wait Zone	OFF / EUS(1~10%)	PROG	OFF
	Wait Time	OFF(0.00)~99.59 (Refer to time unit)	PROG	OFF(0.00)
	Start set value	0.0~100.0% of input range	PROG	EU(0.0%)
	Standard of start	SSV:Start set value / PV1:Process value PV2:time prior set value	PROG	SSV
	Set SV1	EU(0.0~100.0%)	PROG	EU(0.0%)
	Time setting of fist step	OFF / 0.00~9959	PROG	OFF
~~~~~				
	Set SV10	0.0~100.0%	PROG	EU(0.0%)
	Time setting of tenth step	OFF / 0.00~99.59	PROG	OFF
	Condition select after finishing program control	Reset / Repeat / Local / Hold	PROG	RST



This controller has two types of auto-tuning as STD (Standard type) and LOW(Low PV type). Low PV type is the value 10% lower than the set value. Use this type where overshoot is to be suppressed.

Auto-tuning: The Auto-tuning function automatically measures, computes and set the optimum P.I.D and ARW constants. The Auto-tuning function can be activated at any time during the process after power ON; while temperature is rising or when control has stabilized.

Auto tuning is not operated when selecting " OFF " in selection mode of auto tuning start.

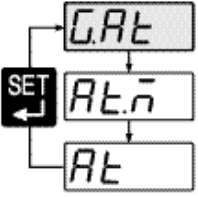
Signal	Name	Description	Condition	Initial value
	Auto tuning group	Indicates Auto tuning	—	—
	Auto tuning type	STD / LOW	ABS	STD
	Auto tuning start	OFF / 1~3 / AUTO	ABS	OFF

When checking P.I.D. values or setting SV in manual mode, this can be done in P.I.D. Group.

Press key to get Anti Reset Wind value by auto or manual and then press once more to be indicated P.I.D mode which is selectable 3 types of P.I.D group (0~3). Example, "0" is no P.I.D mode and after Auto tuning "1" using or and pressing , it is available to change P.I.D value in zone "1" ("2" and "3" are same as "1")

When integral time is 0, manual reset mode is indicated and then you could set reset value to remove off set (range: -5%~105.0% of proportional band). You could set 3 zones by selecting zone mode ON.

In diagram, "n" is available to set 1~3 and proportional band of cooling side, integral time of cooling side, hysteresis are indicated in Heating / Cooling type.

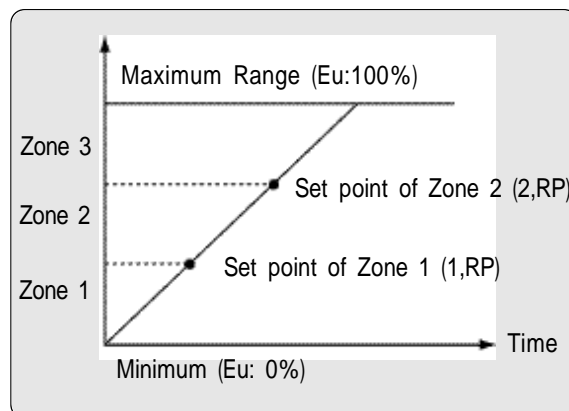

Signal	Name	Description	Condition	Initial value
	P.I.D group	Set P.I.D mode	—	—
	Anti Reset Wind-Up	Auto / 50.0~200.0%	P.I.D control	Auto
	P.I.D group selection	0 / 1~3	Always	0
	n. Proportional band(P)	0.1 (H/C TYPE:0.0)~999.9%	P.I.D group	5.0%
	n. Integral time (I)	OFF / 1~600 sec.	Always	240 sec.
	n. Derivative time (D)	OFF / 1~6000sec.	Always	60 sec.
	n. Manual reset	-5.0~105.0%	Integral time: OFF	50.0%
	n. Proportional band of cooling side (P)	0.0 (ON/OFF control) / 0.1~999.9	Heating • Cooling type	5.0%
	n. Integral time of cooling side (I)	OFF / 1~6000 sec.	Heating • Cooling type	240 sec.
	n. Derivative time of cooling side (D)	OFF / 1~6000 sec.	Heating • Cooling type	60 sec.
	n. Hysteresis	-100.0~50.0%	Heating • Cooling type	3.0%
	n. Zone point	EU (0) < 1.RP < 2.RP < EU (100.0%)	ZONE = ON	EU(100.0%)

There are 3 alarm outputs available per controller. In Alarm Group, settings are made for mode, dead band, and value of each alarm. Refer to the next page for the 19 different types of alarm functions.

☞ : In Heating · Cooling type of LCU204, LCU208, LCU209, ☞☞ is not indicated when selecting 10, 11, 12

Signal	Name	Description	Condition	Initial value
	Alarm group	Set alarm mode	—	—
	Type of Alarm 1	OFF / 1~22 Refer to "Alarm type and code"	Always	1
	Type of Alarm 2			2
	Type of Alarm 3			1
	Dead band of Alarm 1	EUS ( 0.0~100.0% )	Always	EUS(0.5%)
	Dead band of Alarm 2			
	Dead band of Alarm 3			
	Set value of Alarm 1	PV alarm, Deviation alarm EU ( -100.0~100.0% )	Always	EU(100.0%)
	Set value of Alarm 2			EU(0.0%)
	Set value of Alarm 3			EU(100.0%)

Reference : Display lamp will be OFF when output ON in inverted type.

### Hold function

Without hold function, Low limit alarm will be ON when increasing temperature. (Picture 1)

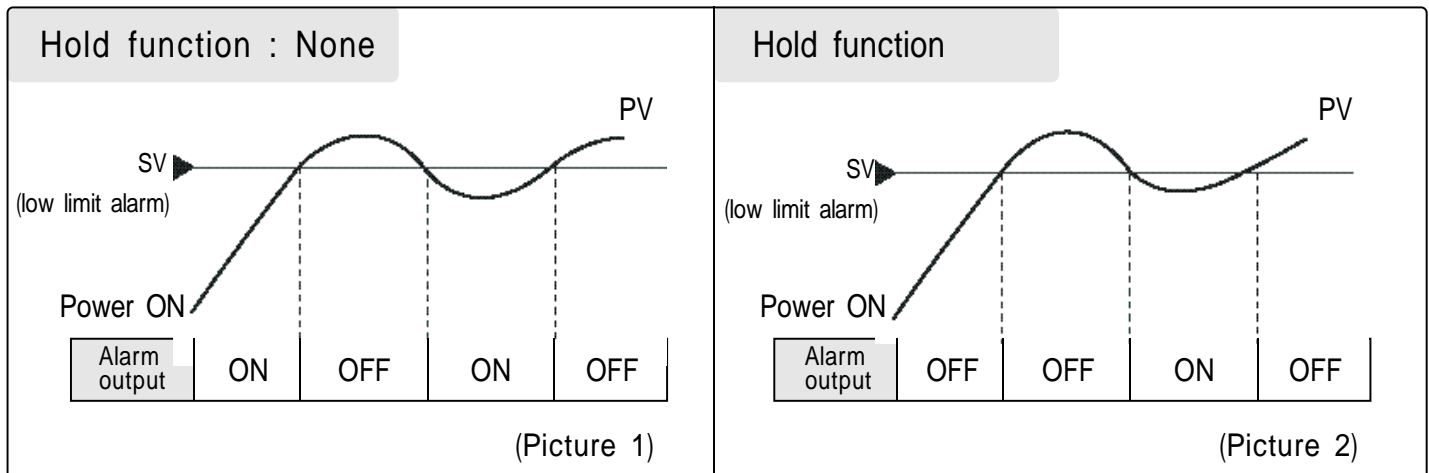



# ALARM TYPE AND CODE

(Notice) : Display lamp will be ON when output OFF in inverted type.

Hysteresis  (  : Set point ,  Minus Alarm set point ,  : Alarm set point )

Code NO.	Alarm type	Function
1	High absolute value	
2	Low absolute value	
3	High deviation value	
4	Low deviation value	
5	High deviation value (inverted)	
6	Low deviation value (inverted)	
7	High · Low deviation value	
8	High · Low band	
9	High absolute (inverted)	
10	Low absolute (inverted)	
11	High absolute with hold function	
12	Low absolute with hold function	
13	High deviation with hold function	
14	Low deviation with hold function	
15	High deviation with hold function (inverted)	
16	Low deviation with hold function (inverted)	
17	High · Low deviation with hold function	
18	High · Low band with hold function	
19	High absolute value with hold function (inverted)	
20	Low absolute value with hold function (inverted)	
21	Heater break alarm 1 ( HBA 1 )	
22	Heater break alarm 2 ( HBA 2 )	

Reference : Retransmission group will be indicated when selecting retransmission in output group.  
If selecting code 4,5,7 or 8 in output group, retransmission will not be indicated.

Signal	Name	Description	Condition	Initial value
	Retransmission group	Set retransmission mode	Reference	—
	Retransmission type or Power for sensor	PV / SV / Output volume (MV) Power for sensor (SPS)	Optional	PV
	High limit of retransmission	Thermocouple / R.T.D : FR -H ~ FR- L DC voltage : SL -H ~ SL-L but, RET. H > RET.L	PV / SV	
	Low limit of retransmission			

LCU2 series are equipped with 4 wire / 2 wire half-duplex the RS485 / RS422 communication interfaces.

Using the interfaces, communications are available with maximum 31 devices.

Signal	Name	Description	Condition	Initial value
	Communication group	Set communication mode	—	—
	RS485/RS422 Protocol	PC.LINK(Set value:0) / PC.LINK SUM (Set value:1)	Optional	0
	Communication rate (B.P.S)	600(SV:0) / 1200(SV:1) / 2400(SV:2) 4800(SV:3) / 9600(SV:4)		4
	Parity check	NONE(SV:0)/EVEN(SV:1)/ODD(SV:2)		1
	Stop bit	1bit (SV:1) / 2bit (SV:2)		1
	Data length	7bit (SV:7) / 8bit (SV:8) (Except PC LINK :8)		8
	Address	1~99 , maximum 31 devices		1
	Response time	0~10. response time = (handling time + response time) X 10ms		0

Heater break alarm group consist of output dead band and current detection display mode and detects 2 spots (to be ordered seperately: current transformer model CTL-6-S. measurement range : 1~50A).

Signal	Name	Description	Condition	Initial value
	Heater break alarm group	Set HBA mode	—	—
	Current setting mode of HBA 1	OFF / 1~50A	Optional	OFF
	Current setting mode of HBA 2	OFF / 1~50A		OFF
	Hysteresis setting mode HBA 1	EUS (0.0~100.0%)		EUS(0.5%)
	Hysteresis setting mode HBA 2	EUS (0.0~100.0%)		EUS(0.5%)
	Current measurement value of HBA 1	Only display (0~50A)		
	Current measurement value of HBA 2	Only display (0~50A)		

Ⓔ : There is no HBA function in LCU208, LCU209.

If selecting REMOTE in Control group, set value will be set by remote set.

In remote condition, SV is changeable by front keys, but the controller is controlled by external set value. Do not change set value by remote in auto tuning.

Signal	Name	Description	Condition	Initial value
	Remote group	Set remote mode	—	—
	High limit voltage of remote input	1,000~5,000V but, R. INH > R. INL	Optional	5.000
	Low limit voltage of remote input			1.000
	High limit on scale	Thermocouple : FR-H ~ FR-L DC voltage : SL-H ~ SL-L Decimal point is set by DP-P.		Ⓔ 1
	Low limit on scale			Ⓔ 2
	PV Filter	OFF / 1~120		OFF
	PV Bias	EUS (-100.0~100.0%)		EUS(0.0%)

Ⓔ 1 : Thermocouple, R.T.D input ( FR-H ), DC voltage ( SL-H )

Ⓔ 2 : Thermocouple, R.T.D input ( FR-L ), DC voltage ( SL-L )

Ⓔ EUS : Range at an engineering unit in compliance with the span of an instrument.

MEMO

LOVE CONTROLS

**PROHEAT**

*Excellence in distribution*

<http://www.proheatinc.com>

117 East Adams Street

P.O. Box 48

LaGrange, KY 40031

Phone (502) 222-1402 Fax (502) 222-0714